

SHIPS + MORE

fischertechnik 

ADVANCED

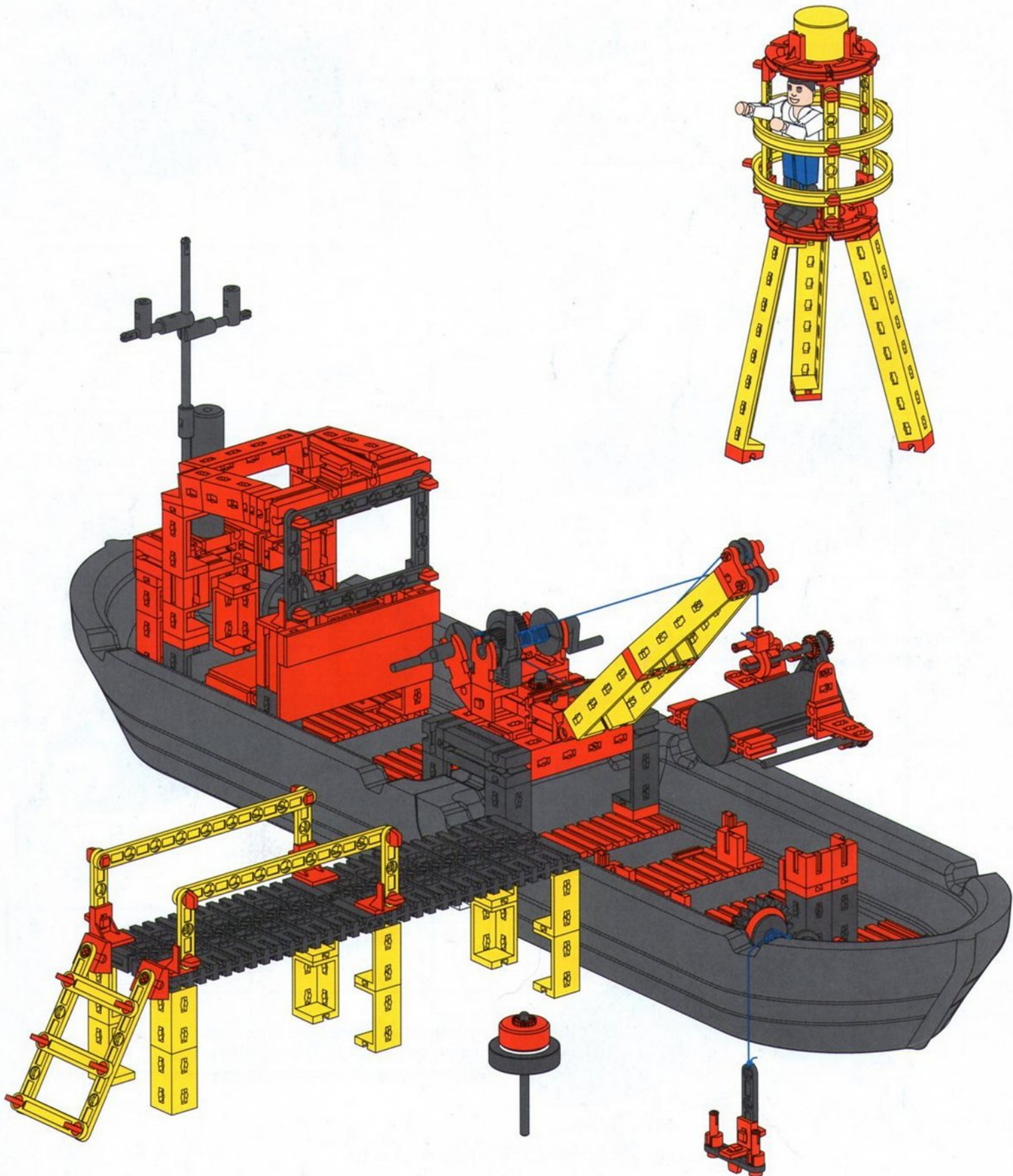

Inhalt
Contents
Contenu

Inhoud
Contenido
Conteúdo

Einzelteilübersicht / Spare parts list / Liste des pièces détachées / Onderdelenoverzicht / Lista da peças / Resumo de peça individual S. / p. 1

Montagetipps / Tips for assembly / Tuyaux pour le montage / Montagetips / Consejos para el montaje / "Dicas" para montagem S. / p. 2

Ausflugsschiff mit Anleger / Excursion ship with landing pier /
Navire d'excursions avec quai d'amarrage / Excursieboot met aanlegplaats /
Embarcación de recreo con embarcadero / Barco de passeio com atracadouro . . . S. / p. 4

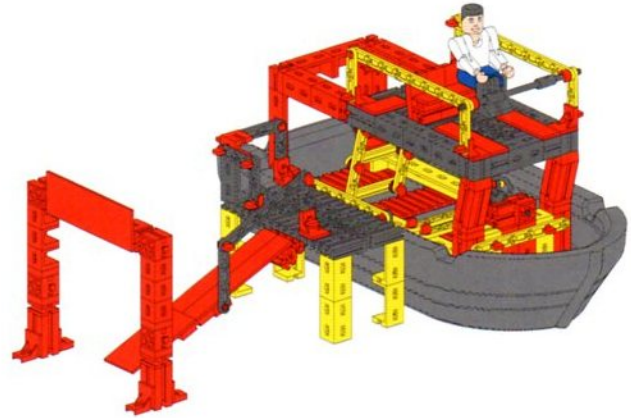





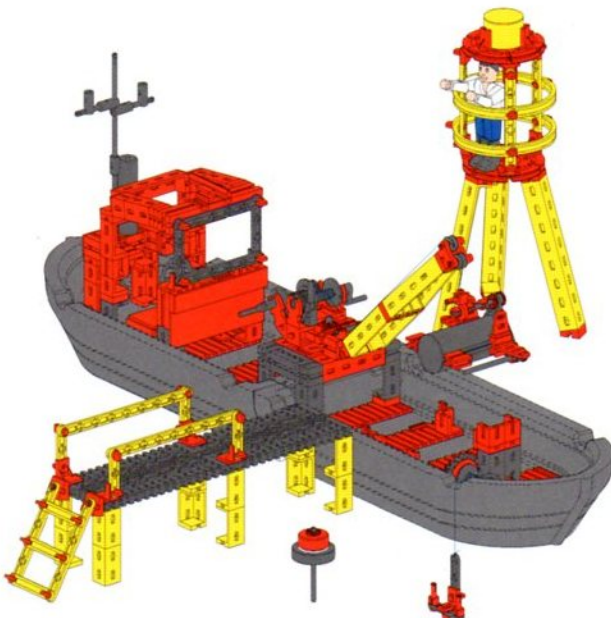
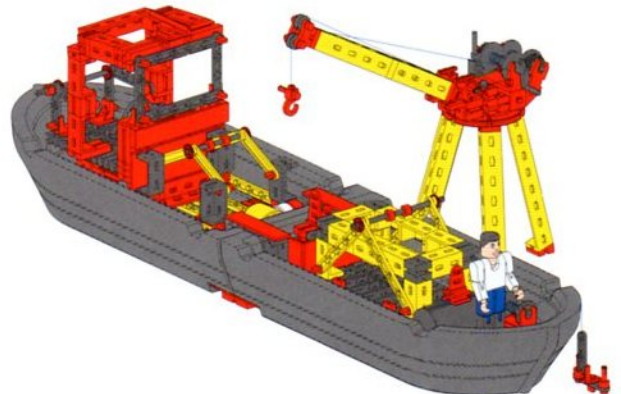









Hafenschlepper mit Schute / Harbor tug with barge /
Remorqueur portuaire avec barge / Havensleper met schuit /
Remolcador de puerto con barcaza / Rebocador com batelão S. / p. 10



Frachtschiff und Kran / Cargo ship and crane / Cargo et grue /
Vrachtschip en kraan / Buque de carga y grúa / Navio de carga e guincho . . . S. / p. 19

















Forschungsschiff und Hafen / Research ship and harbor /
Bâtiment océanographique et port / Onderzoeksschip en haven /
Buque de investigación y puerto / Navio de pesquisa e porto S. / p. 27



Einzelteilübersicht
Spare parts list
Liste des pièces détachées

	31 010 2 x
	31 011 2 x
	31 019 2 x
	31 021 1 x
	31 027 1 x
	31 058 2 x
	31 060 6 x
	31 061 1 x
	31 124 1 x
	31 330 1 x
	31 426 2 x
	31 436 2 x
	31 668 1 x
	31 670 1 x
	31 674 12 x

















	31 690 6 x
	31 707 1 x
	31 848 4 x
	31 916 1 x
	31 981 6 x
	31 982 19 x
	31 994 1 x
	31 997 2 x
	31 998 2 x
	31 999 1 x
	32 064 5 x
	32 071 6 x
	32 085 1 x
	32 200 6 x
	32 851 1 x

Onderdelenoverzicht
Lista da piezas
Resumo de peça individual













	32 859 8 x
	32 870 1 x
	32 879 2 x
	32 881 5 x
	34 994 1 x
	34 995 1 x
	35 031 2 x
	35 049 5 x
	35 052 1 x
	35 060 2 x
	35 063 2 x
	35 064 1 x
	35 066 2 x
	35 069 1 x
	35 070 1 x

	35 073 3 x
	35 129 2 x
	35 409 1 x
	35 806 1 x
	35 980 3 x
	36 227 4 x
	36 294 3 x
	36 297 2 x
	36 299 12 x
	36 323 28 x
	36 324 10 x
	36 334 8 x
	36 581 1 x
	36 702 1 x

Einzelteilübersicht
Spare parts list
Liste des pièces détachées

	36 703 2 x		37 468 18 x
	36 906 2 x		37 679 8 x
	36 912 4 x		38 225 1 x
	36 913 4 x		38 240 13 x
	36 914 4 x		38 241 22 x
	36 920 10 x		38 245 2 x
	36 923 3 x		38 249 1 x
	37 034 10 x		38 251 1 x
	37 237 8 x		38 253 3 x
	37 238 8 x		38 258 2 x

Onderdelenoverzicht
Lista da piezas
Resumo de peça individual

	38 260 2 x		78 728 3 x
	38 413 1 x		116 251 6 x
	38 415 1 x		116 252 4 x
	38 416 3 x		126 927 2 x
	38 423 7 x		127 471 8 x
	38 428 2 x		127 472 6 x
	38 464 3 x		
	38 538 4 x		
	38 542 4 x		
	38 545 10 x		

Montagetipps
Tips for assembly
Tuyaux pour le montage

Montagetipps
Consejos para el montaje
"Dicas" para montagem

<p>Seile Cables Câbles</p> <p>Touwen Cables Cordas</p>		<p>1 x 30 cm</p> <p>1 x 35 cm</p> <p>1 x 65 cm</p> <p>Knoten verhindert ausfransen Knots prevent fraying Le noeud empêche l'effilochage Knopen voorkomen het uitrafelen Nudos impiden el deshilachado Nó para evitar a desintegração da corda</p>
--	---	--

Montagetipps
Tips for assembly
Tuyaux pour le montage

Montagetips
Consejos para el montaje
"Dicas" para montagem

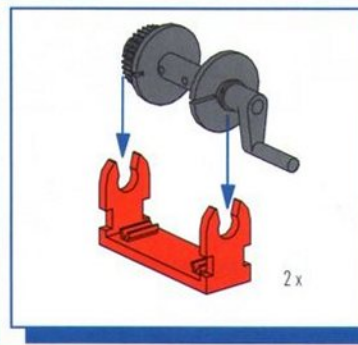
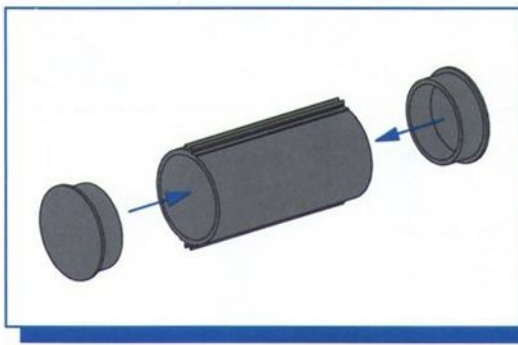
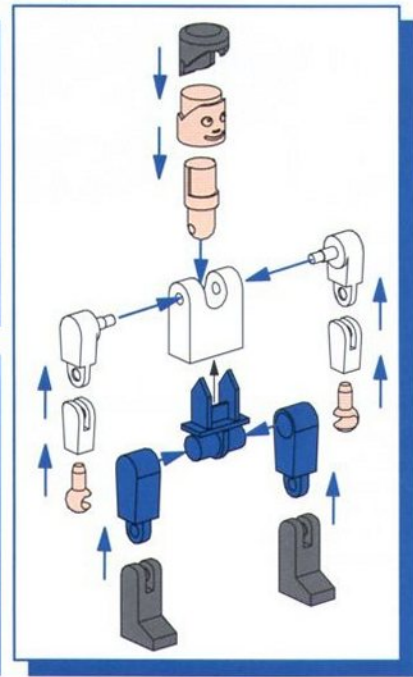

- Alle Einzelteile, insbesondere bewegliche Teile sind falls notwendig zu warten und zu reinigen.
- All components, especially moving parts, should be maintained and cleaned as necessary.
- Toutes les pièces détachées et en particulier les pièces mobiles, sont, si nécessaire, à entretenir et à nettoyer.

- Alle onderdelen, vooral de bewegende delen, kunnen, indien noodzakelijk, onderhouden en gereinigd worden.
- Es necesario limpiar y mantener en buen estado todas las diferentes piezas - especialmente las piezas móviles.
- Caso necessário, todas as peças individuais, especialmente peças móveis, tem que ser submetidas à manutenção e ser limpas.

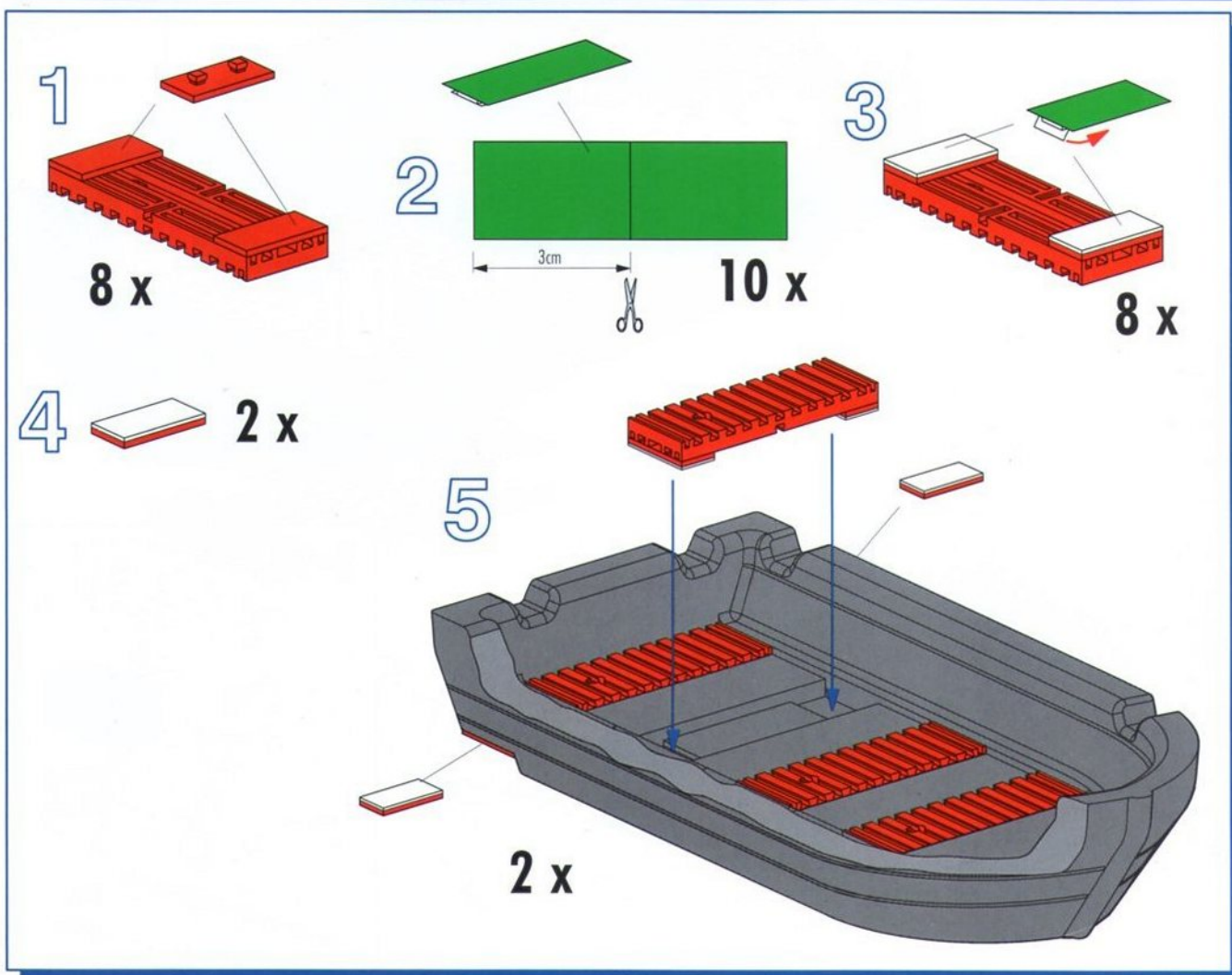

Ausflugschiff mit Anlegestelle
Excursion ship with landing pier
Navire d'excursions avec
quai d'amarrage

Excursieboot met aanlegplaats
Embarcación de recreo con
embarcadero
Barco de passeio com atracadouro

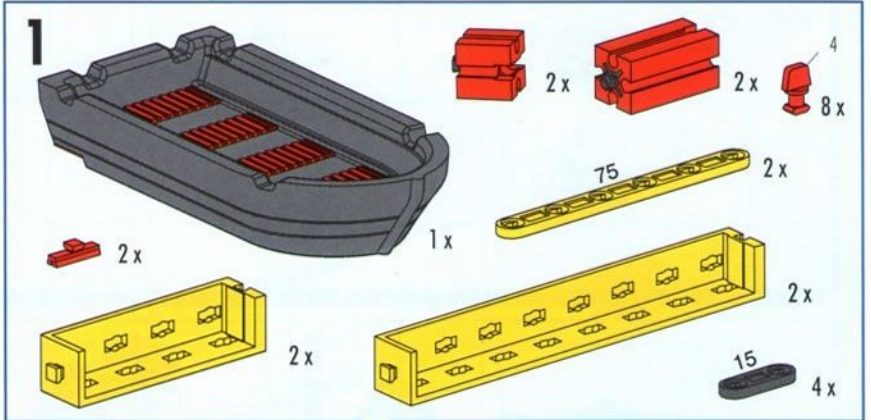
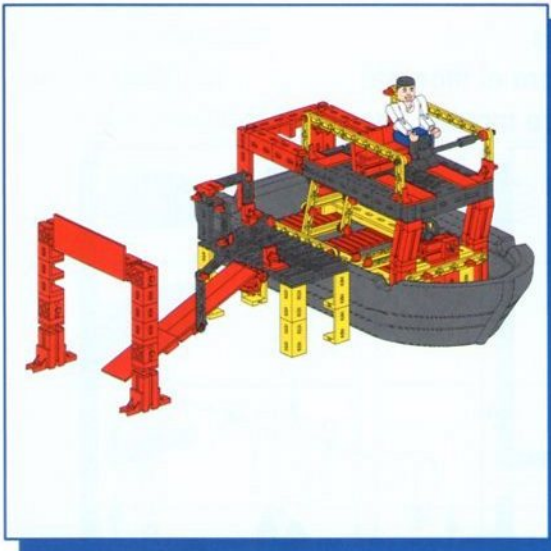

Montagetipps Seite 2
Tips for assembly Page 2
Tuyaux pour le montage page 2
Montagetips zie bladzijde 2
Consejos para el montaje, ver la página 2
"Dicas" para montagem - Página 2

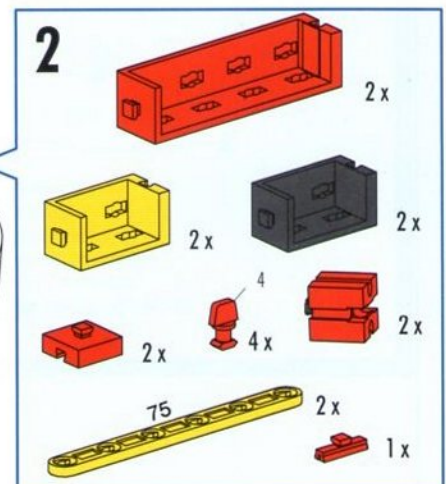
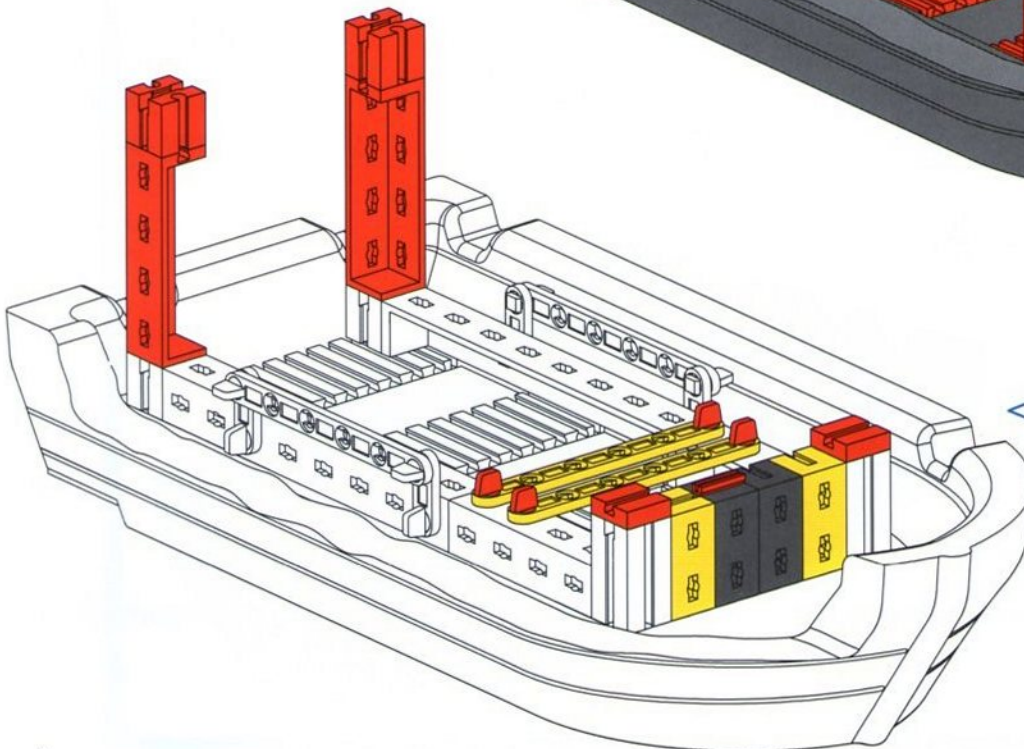
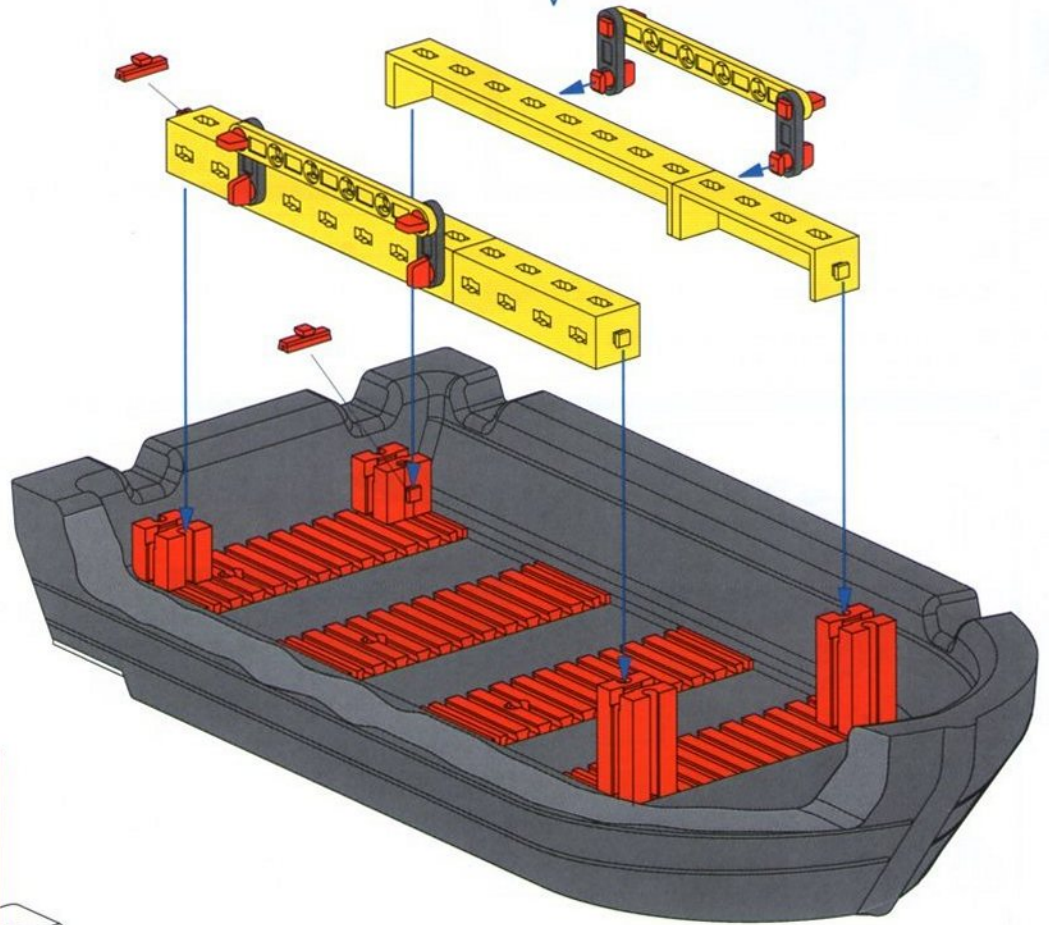

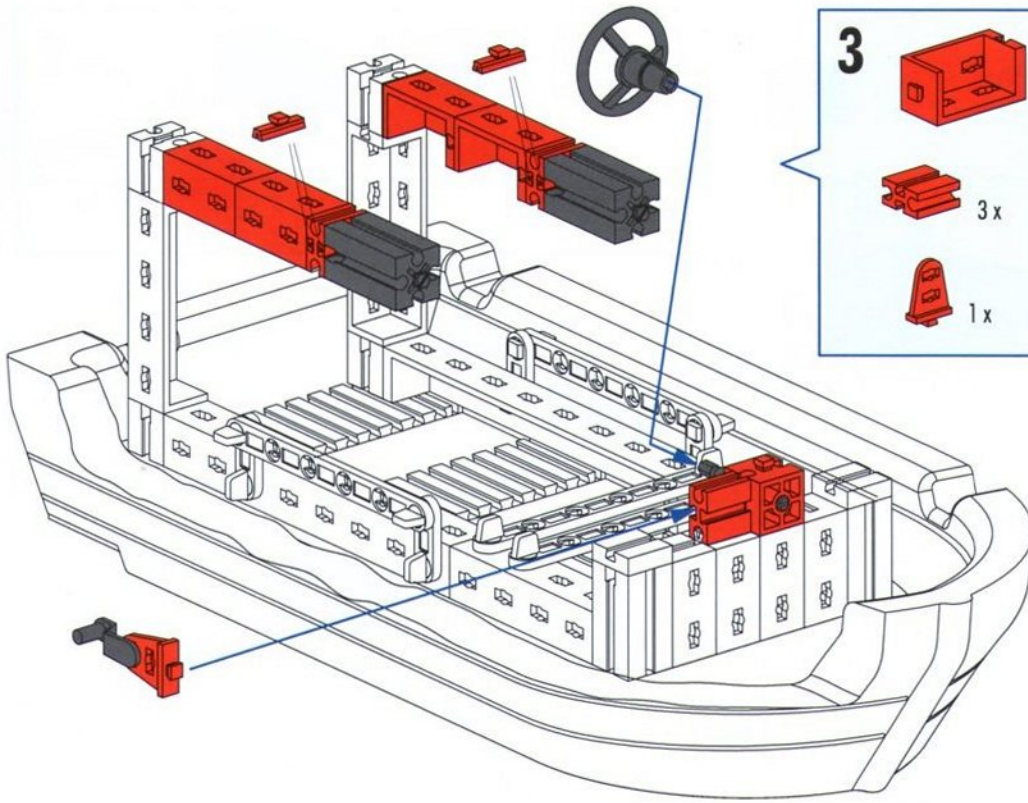

- 3**
- Red 1x4 Technic Beam: 4x
 - Black 1x4 Technic Connector: 2x
 - Grey Steering Wheel: 1x
 - Red 1x2 Technic Connector: 3x
 - Red 1x2 Technic Pin: 4x
 - Red 1x2 Technic Brick: 1x
 - Red 1x2 Technic Pin: 1x
 - Black 1x2 Technic Connector: 1x
 - Grey Axle: 1x

- 4**
- Yellow 75 Technic Beam: 2x
 - Yellow 42.4 Technic Beam: 3x
 - Red 6 Technic Pin: 6x
 - Red 6 Technic Gear: 6x

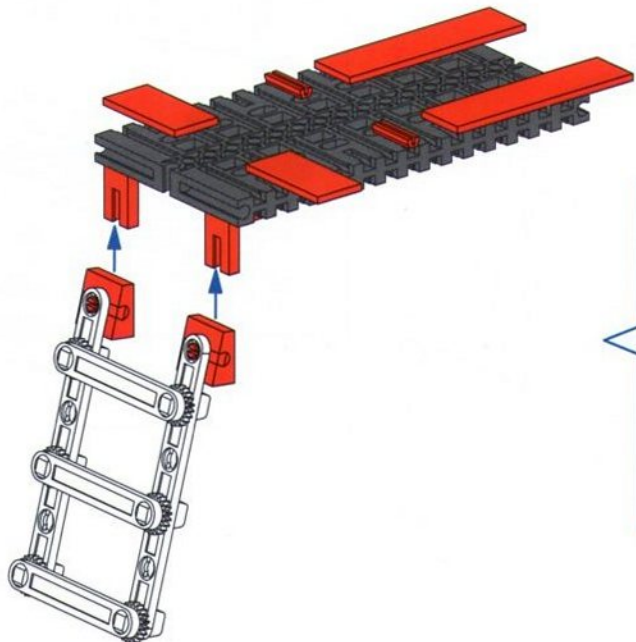
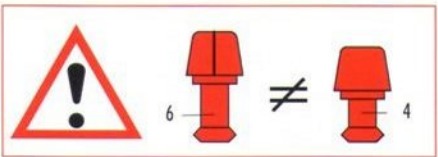
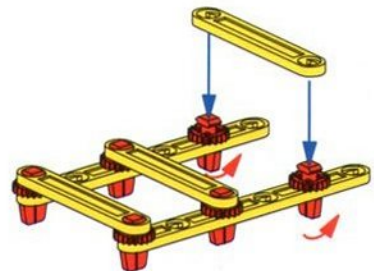

- 5**
- Grey Gear Train Assembly: 1x
 - Red 1x2 Technic Connector: 2x
 - Red 1x2 Technic Pin: 2x
 - Red 1x2 Technic Pin: 2x
 - Red 1x4 Technic Beam: 2x
 - Red 1x2 Technic Beam: 2x
 - Red 1x2 Technic Brick: 2x
 - Red 15° Technic Brick: 2x

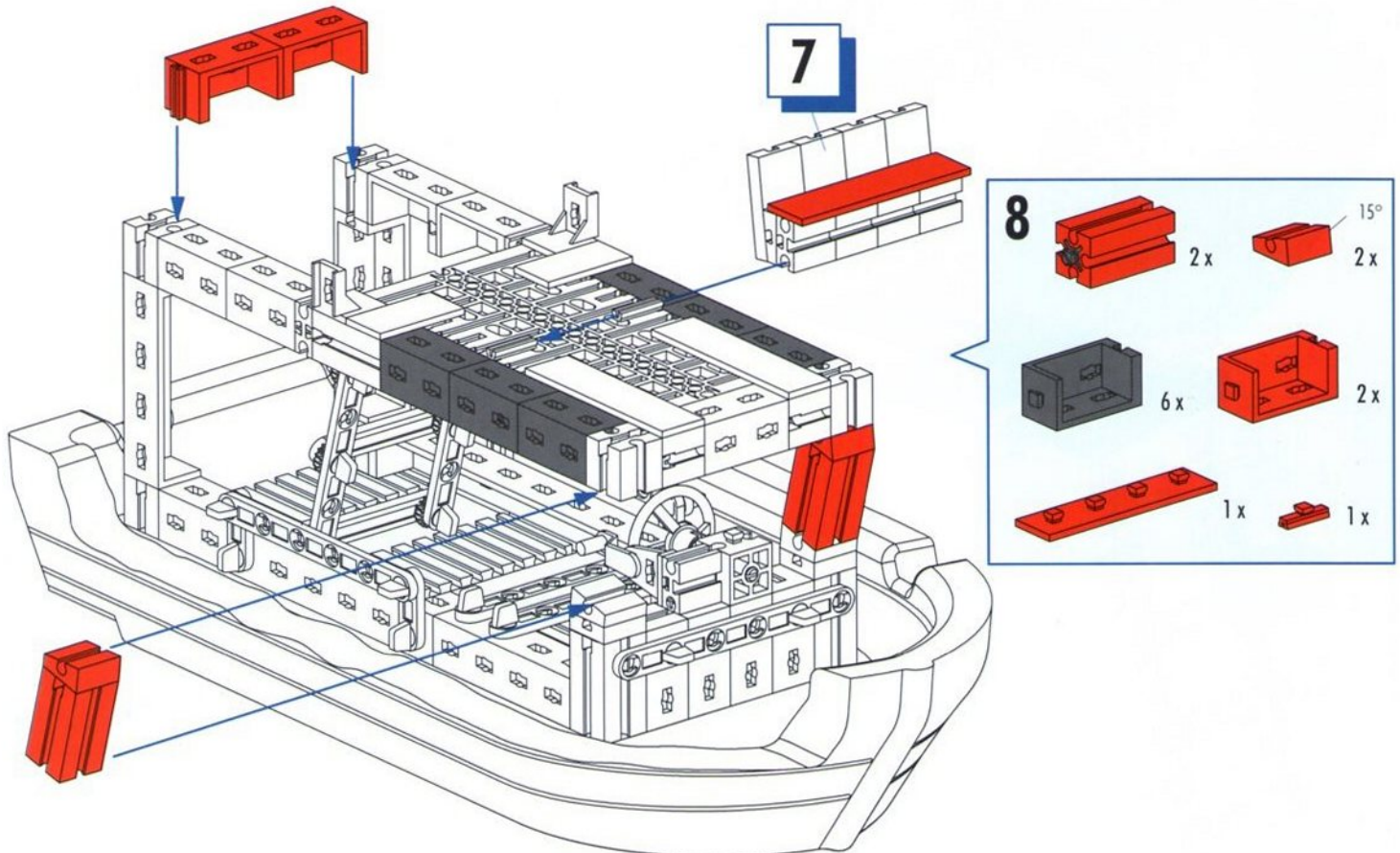
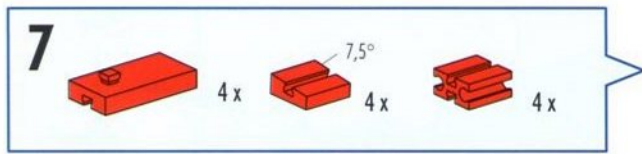
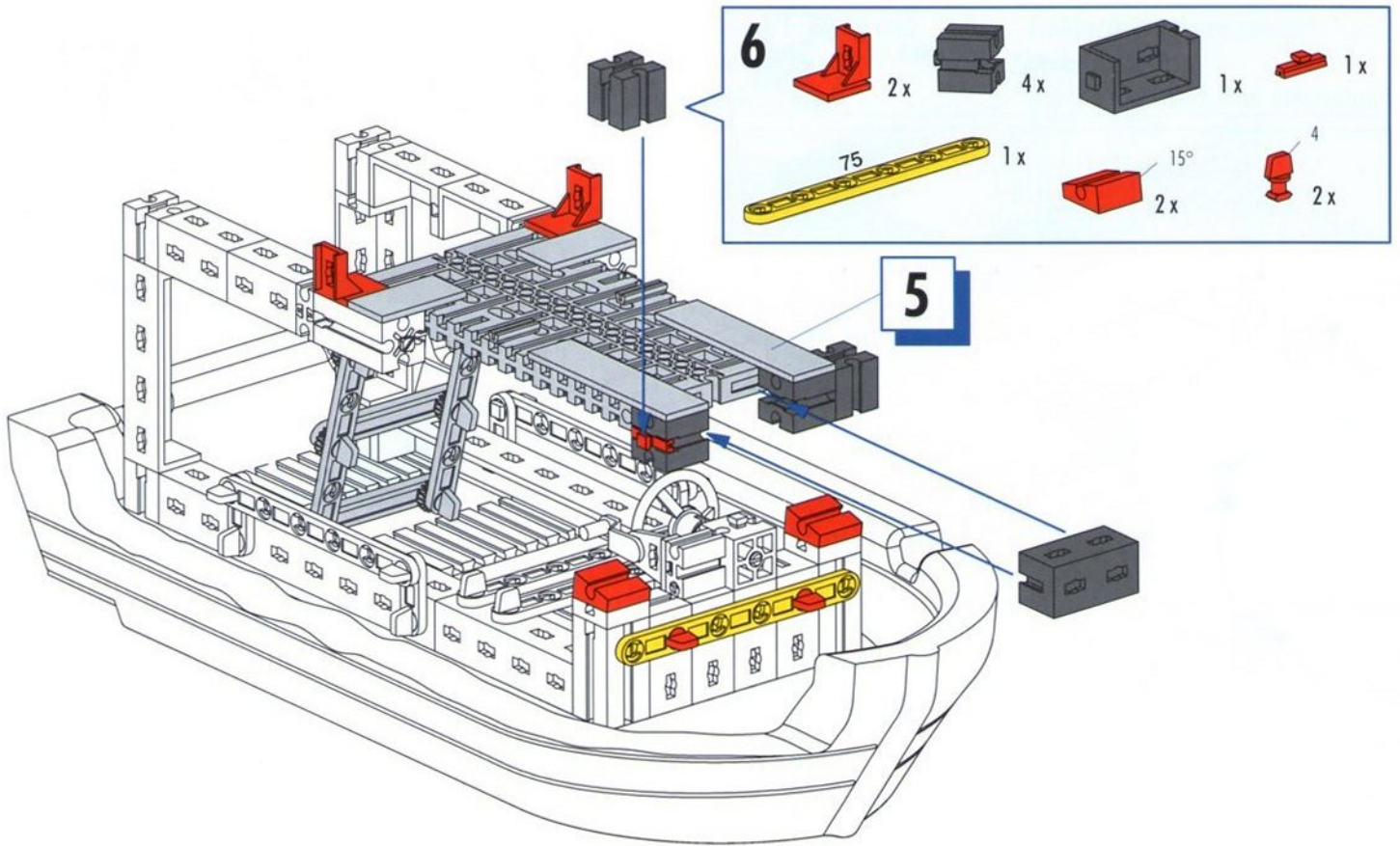

9

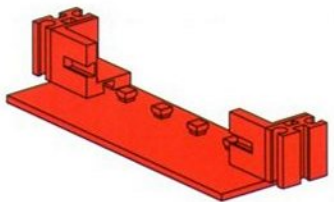
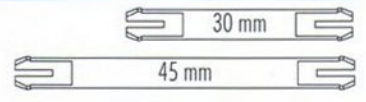
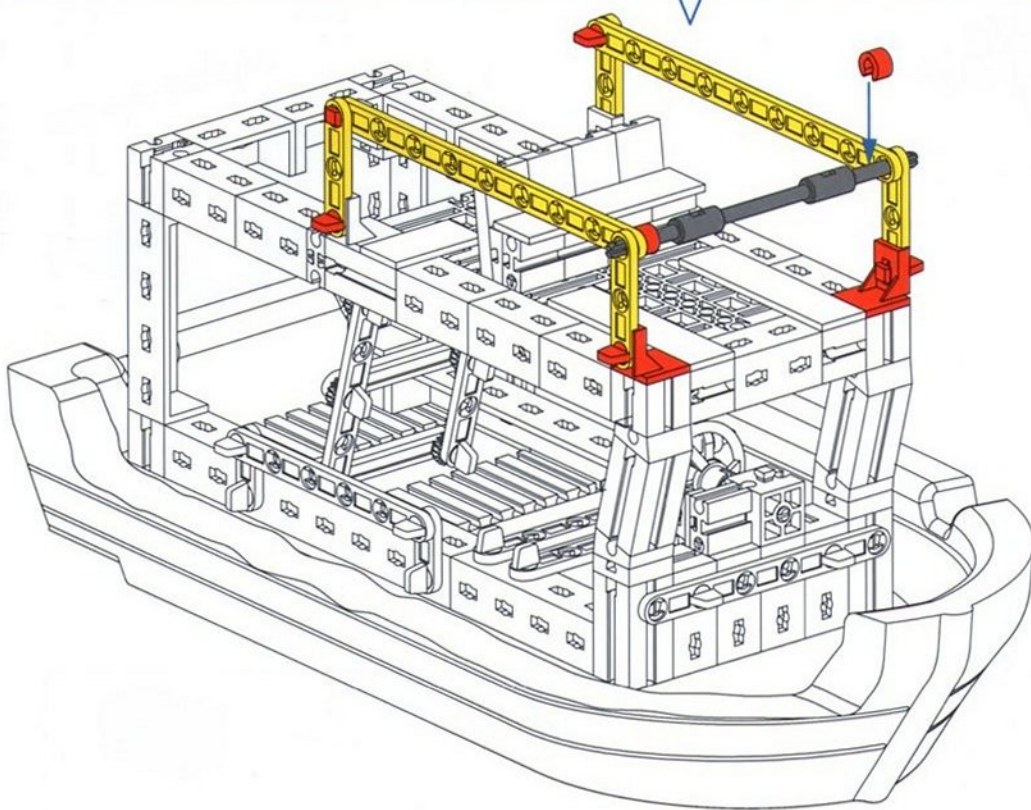
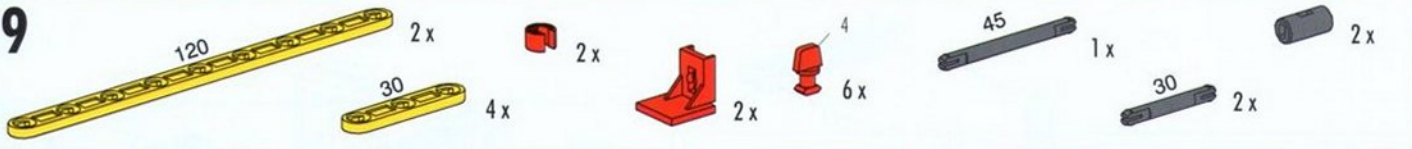

10

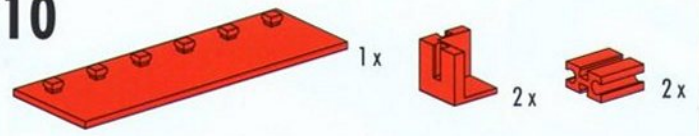

11

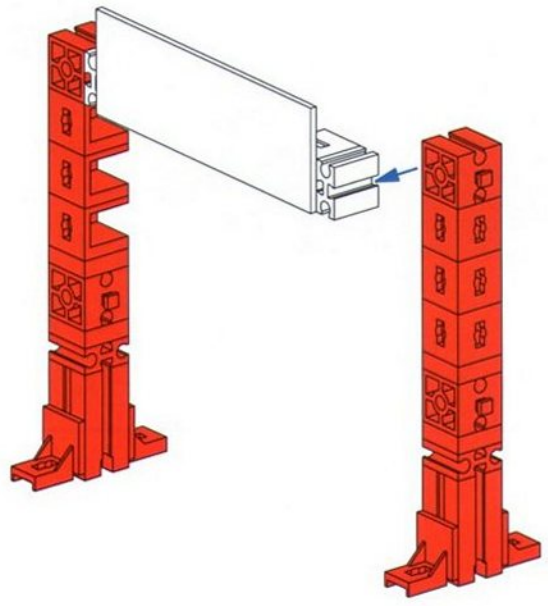
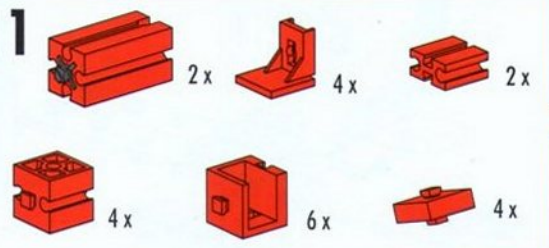

12

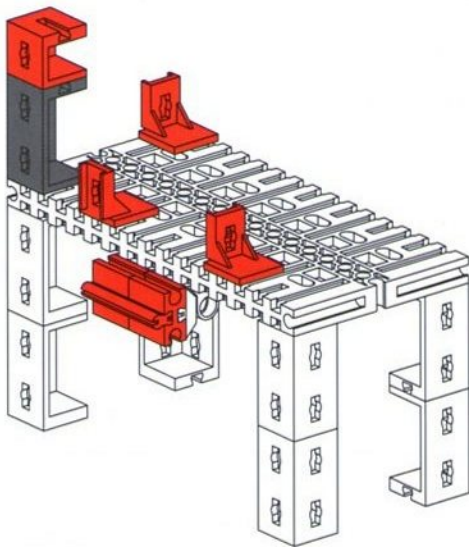
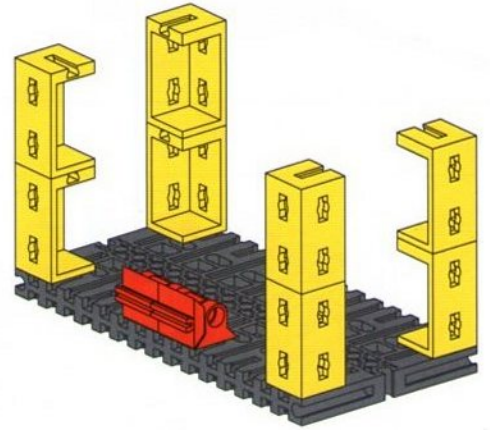
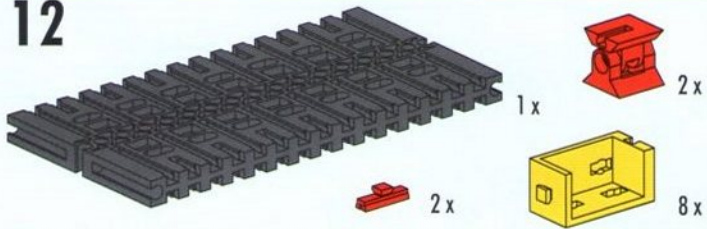

13

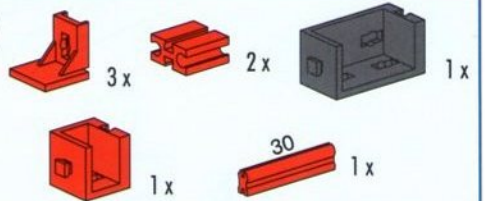

14

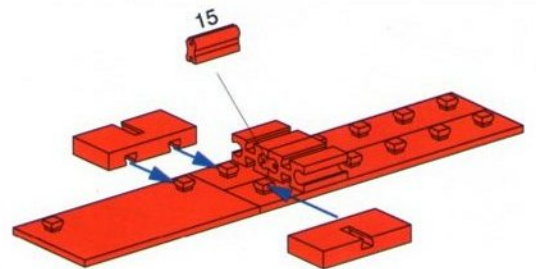
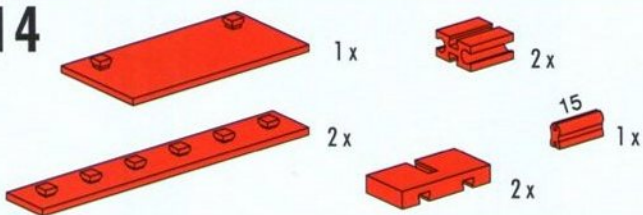

- 15**
- 30 4x
 - 45 2x
 - 75 1x
 - 1x (red bush)
 - 4 (red bush)
 - 8x (red bush)
 - 1x (red bush)
 - 1x (red bush)
 - 1x (red bush)

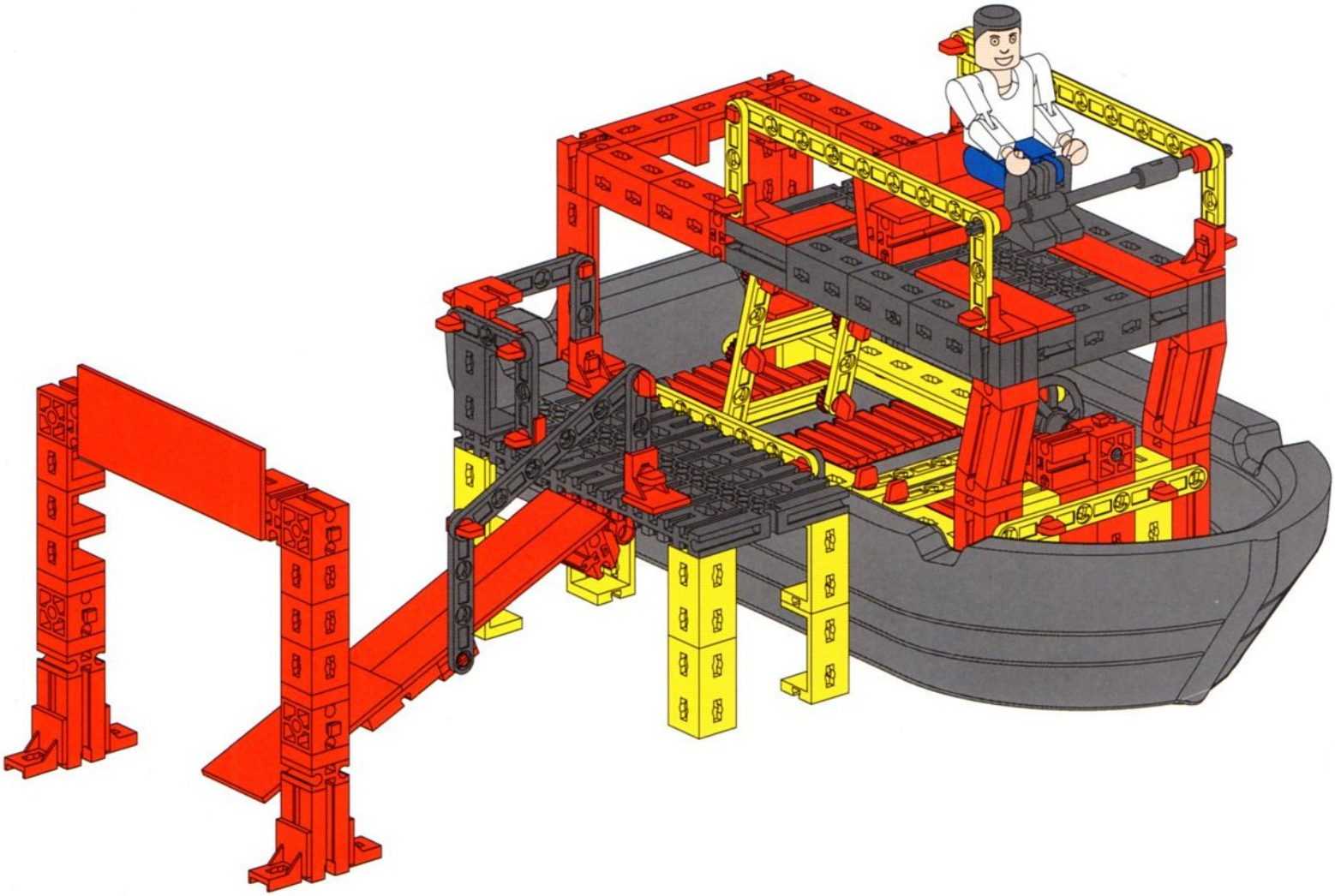
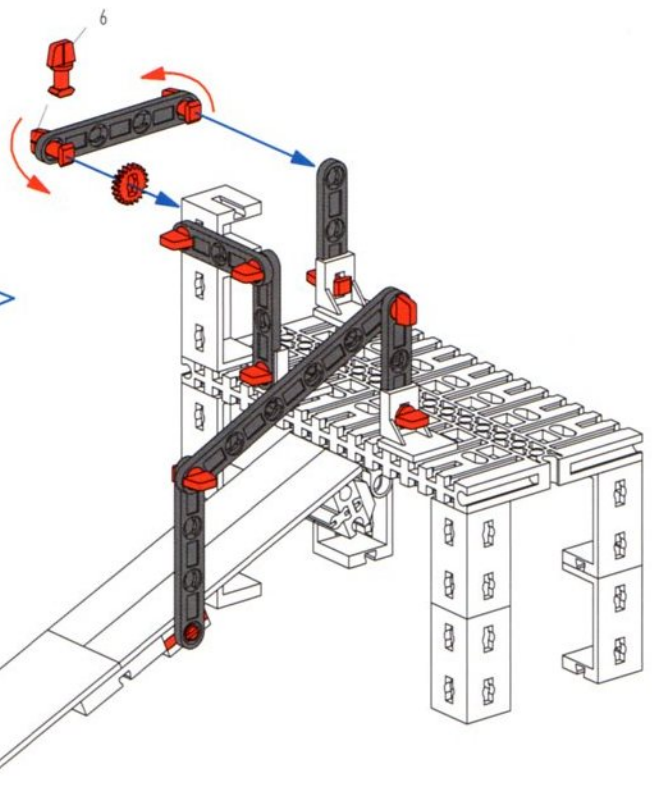
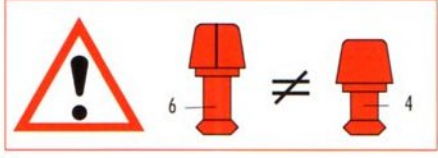

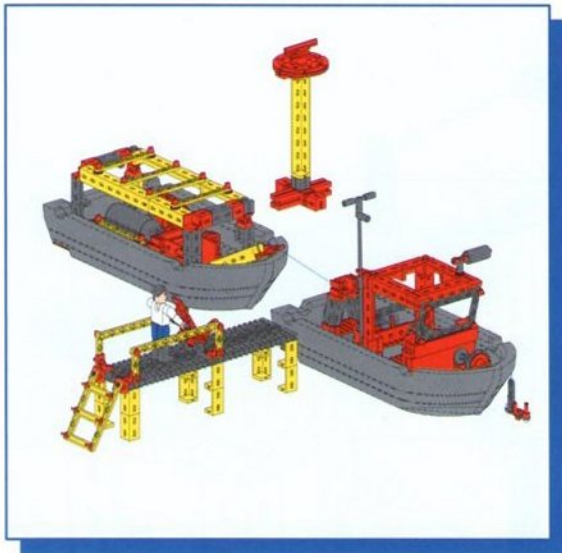

Hafenschlepper mit Schute
 Harbor tug with barge
 Remorqueur portuaire avec barge

Havensleper met schuit
 Remolcador de puerto con barcaza
 Rebocador com batelão

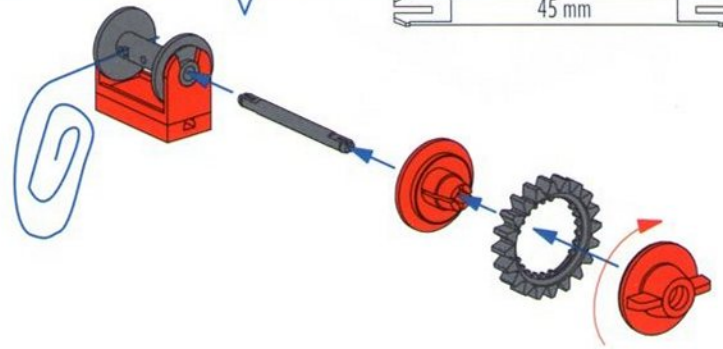
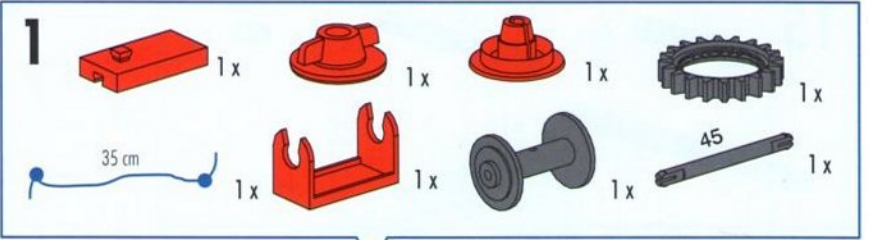

Montagetipps Seite 2
 Tips for assembly Page 2
 Tuyaux pour le montage page 2
 Montagetips zie bladzijde 2
 Consejos para el montaje, ver la página 2
 "Dicas" para montagem - Página 2

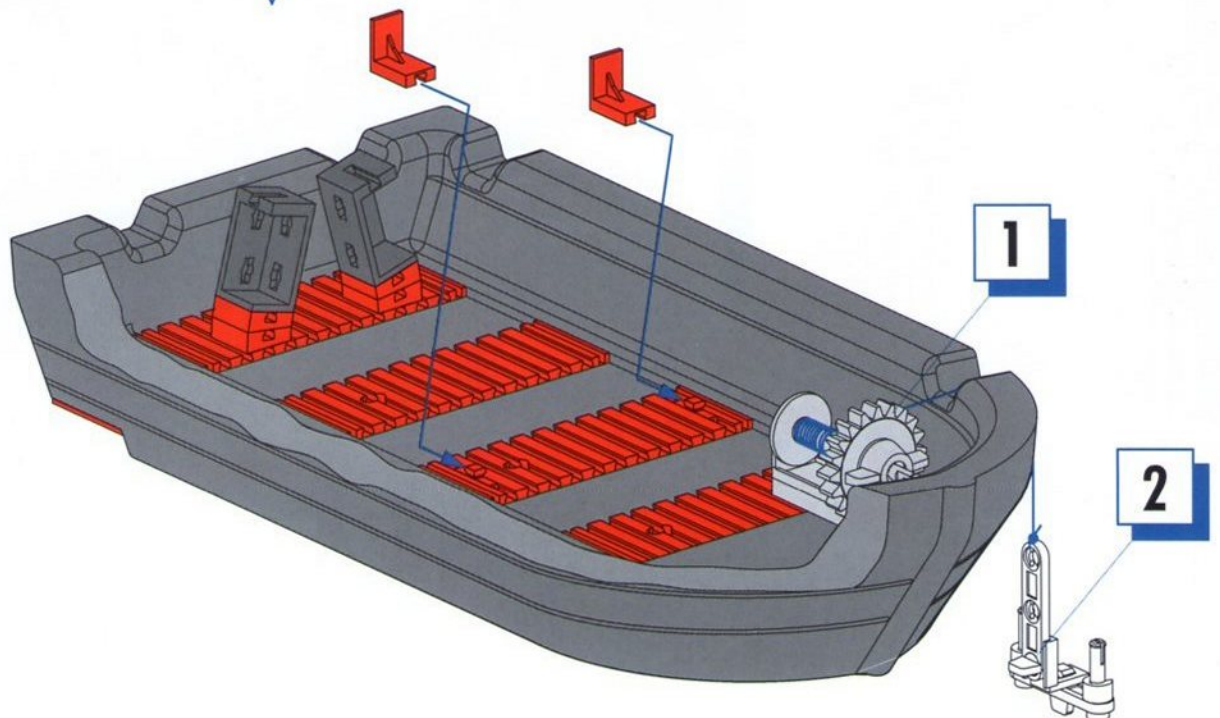
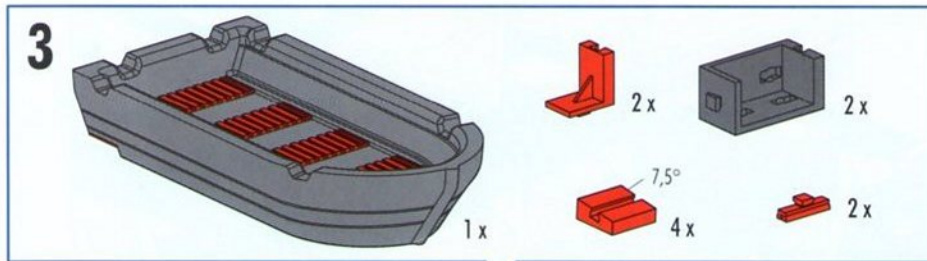
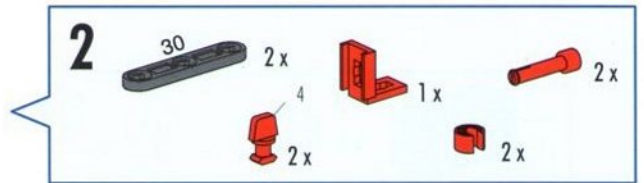
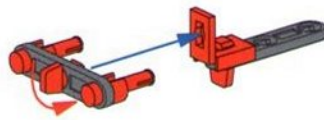

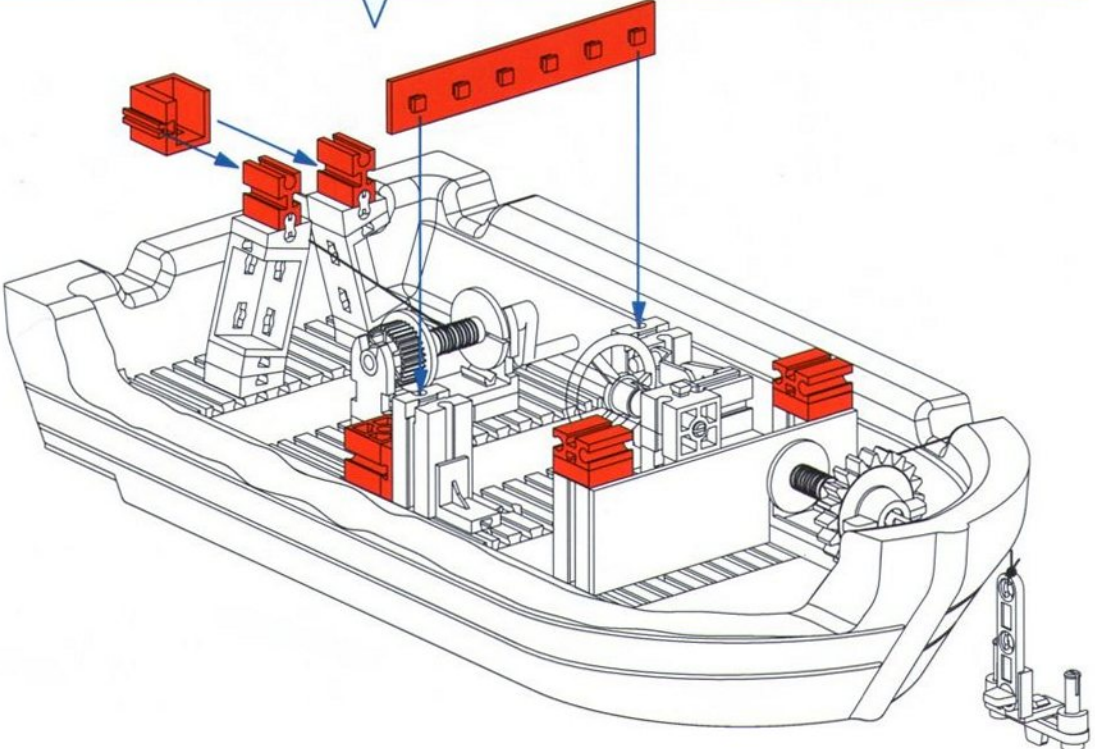
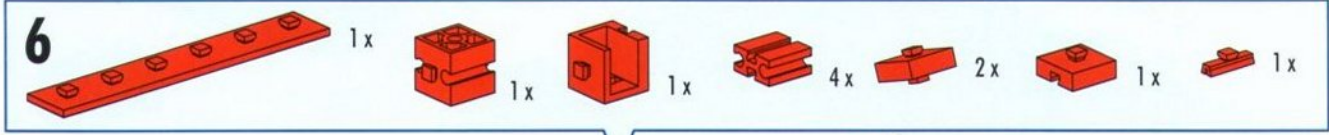
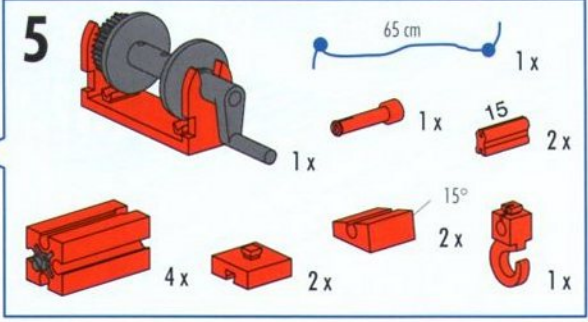
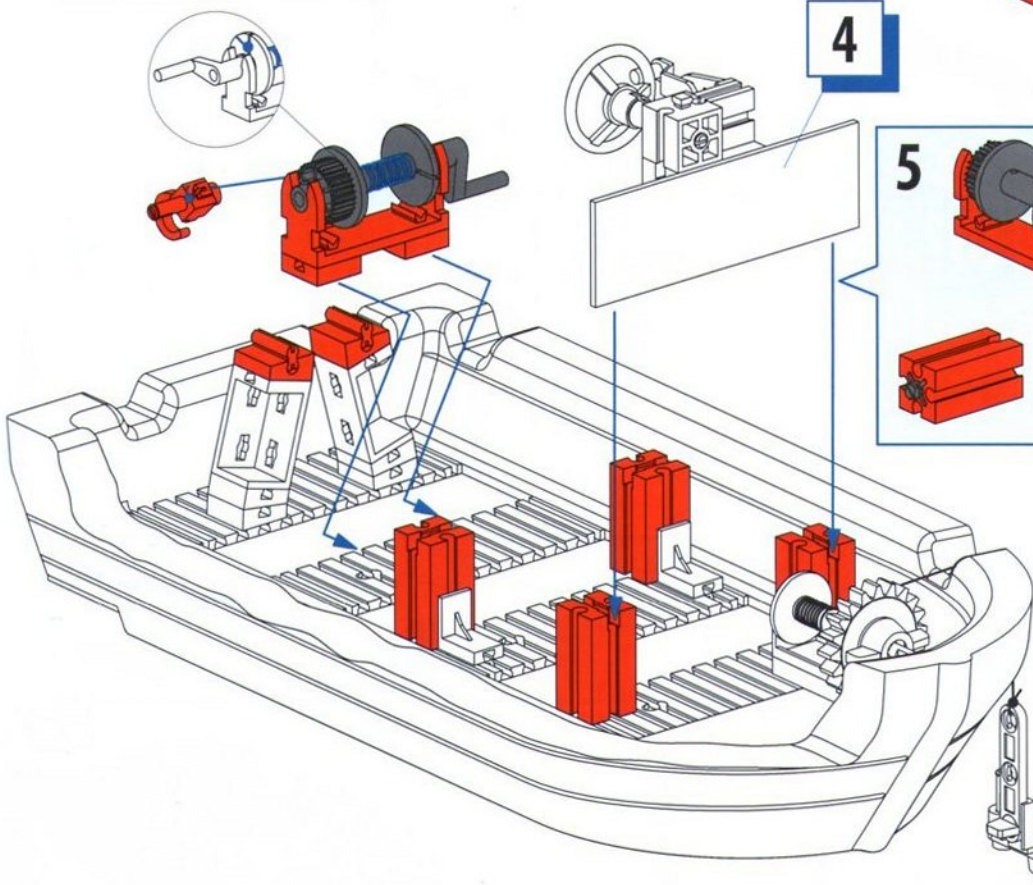
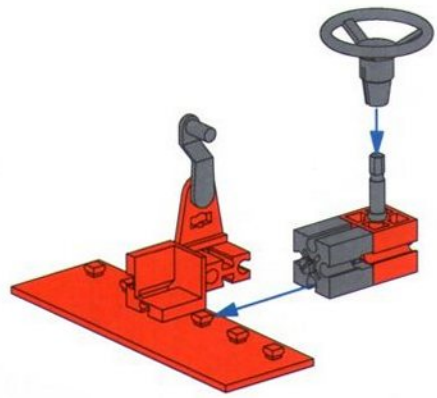
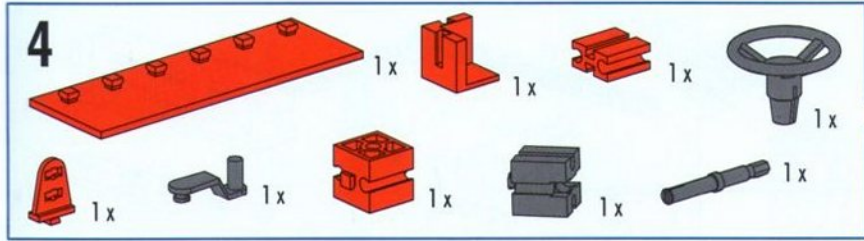

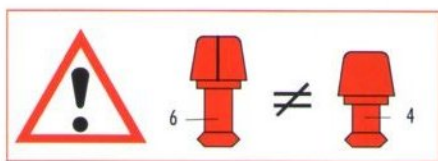
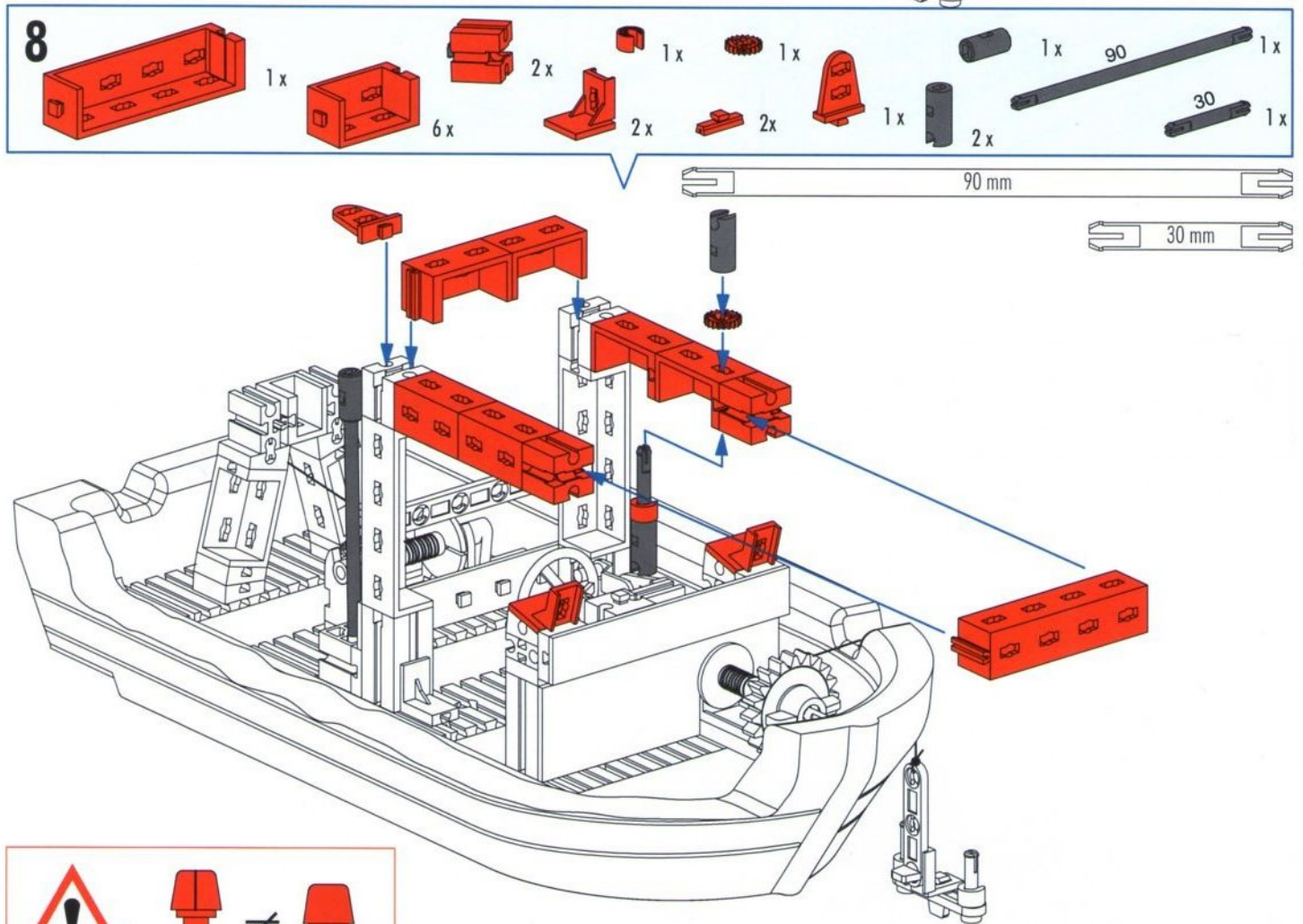
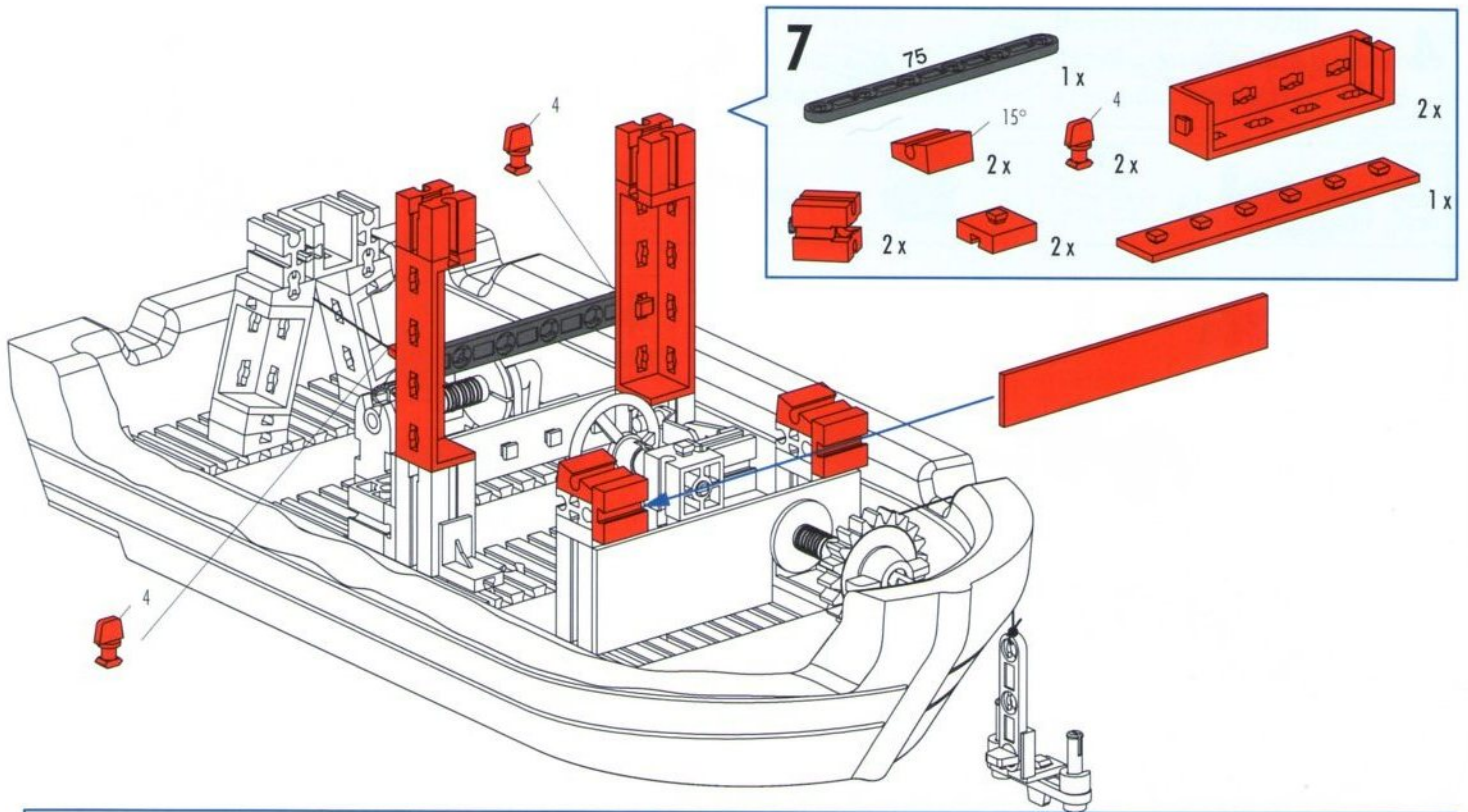

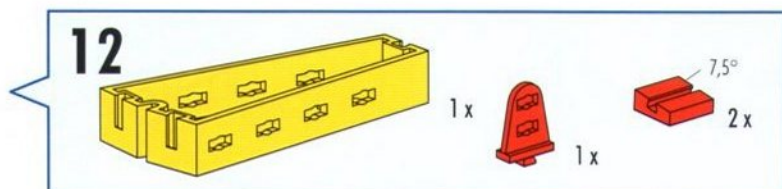
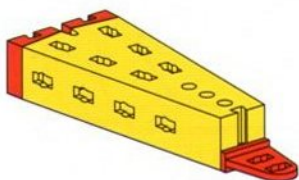
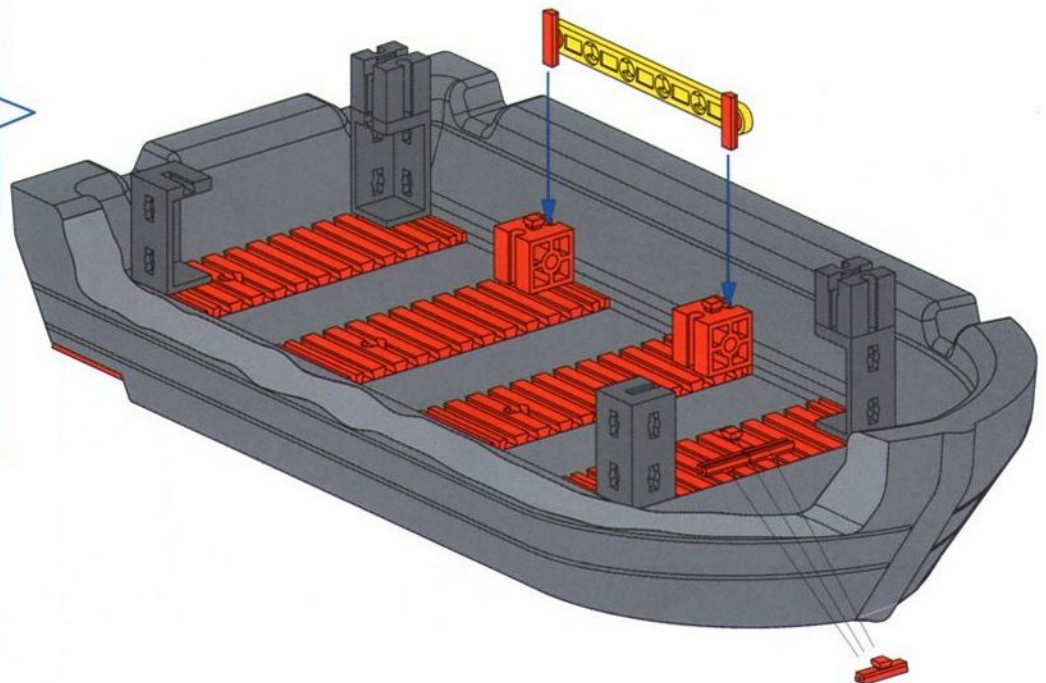
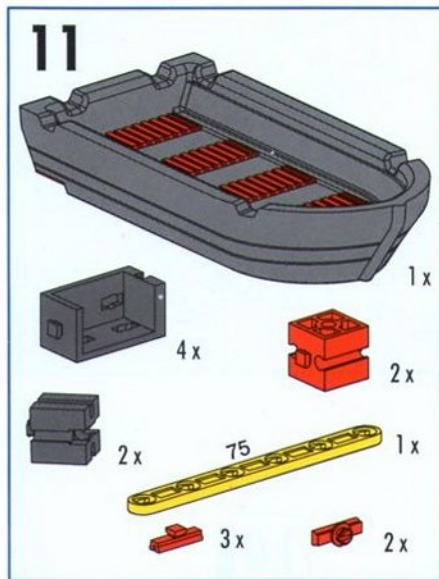
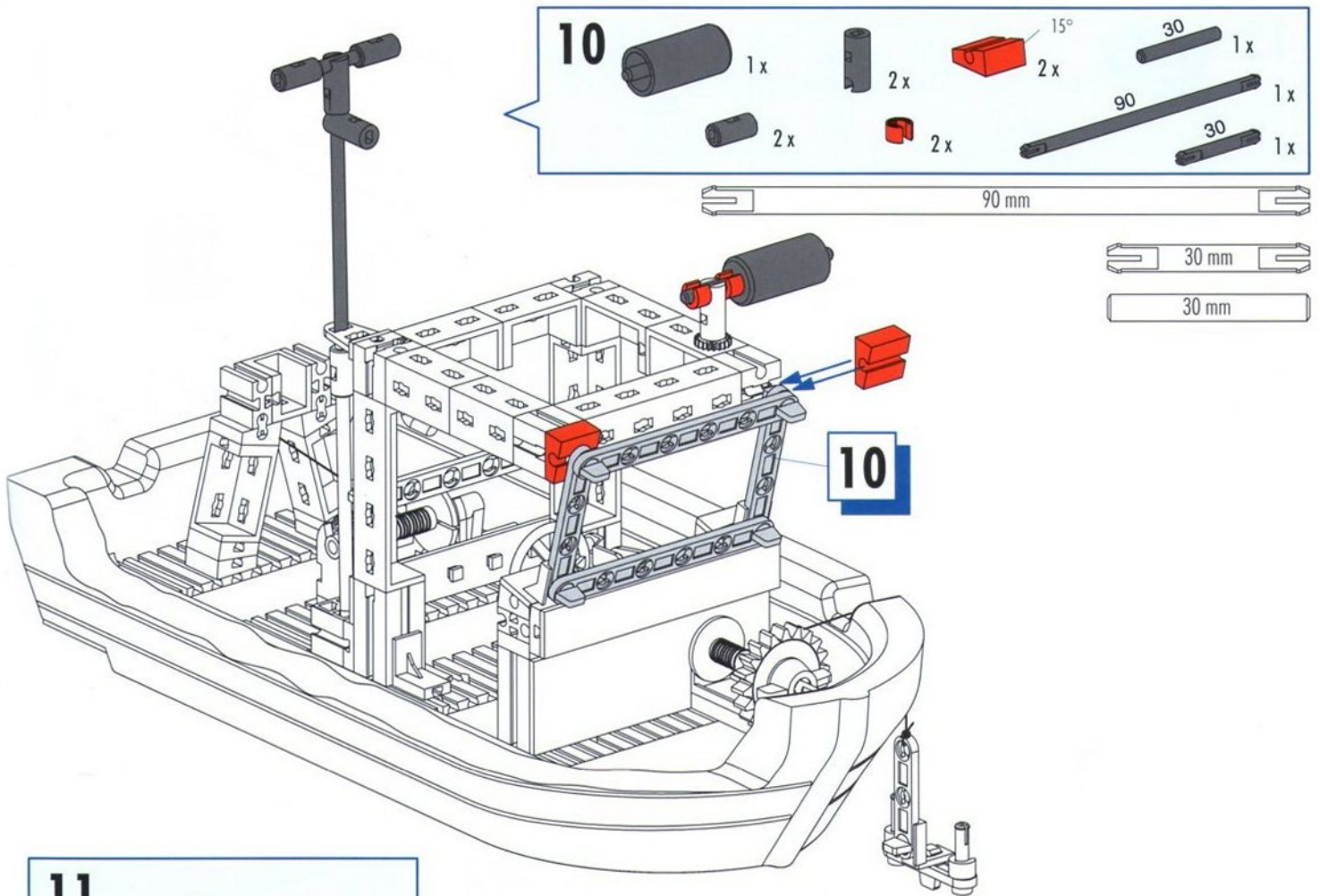

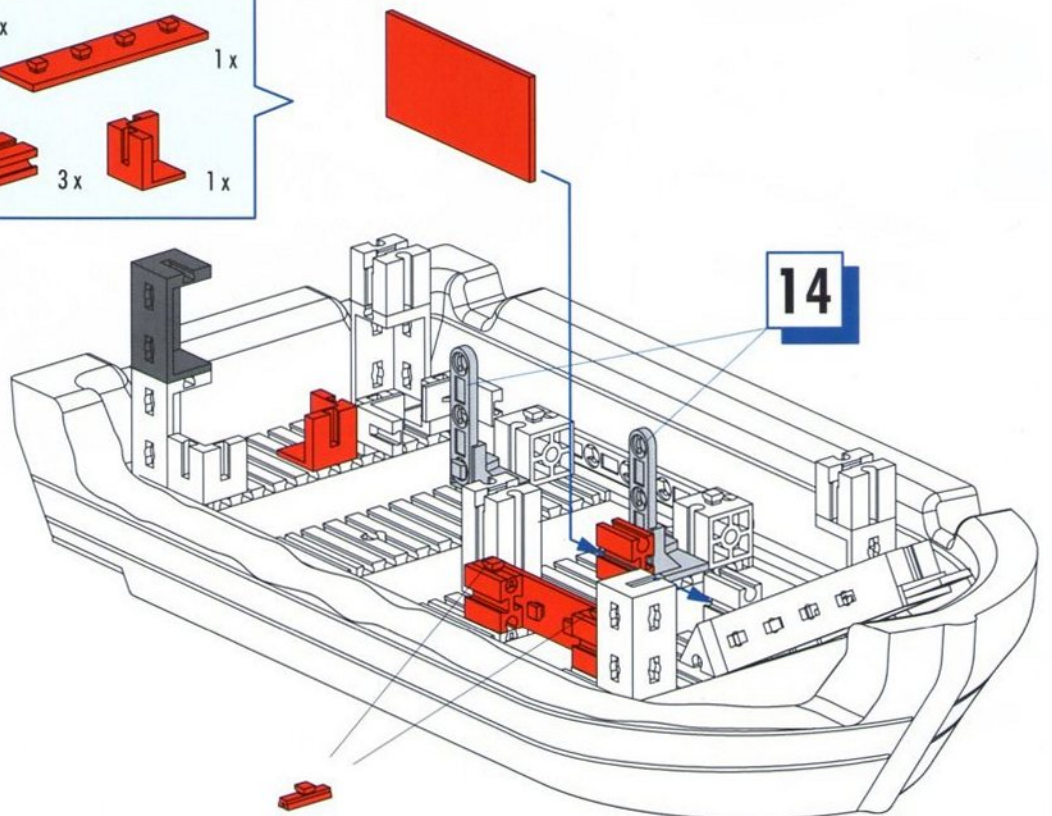
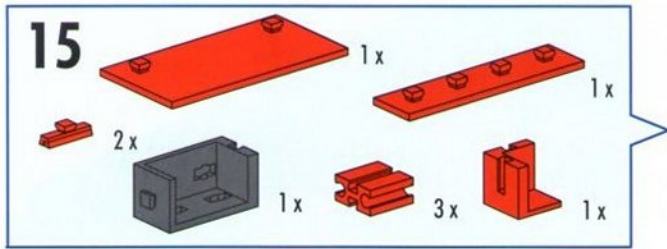
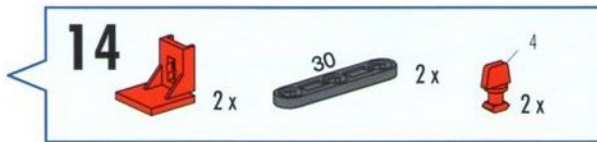
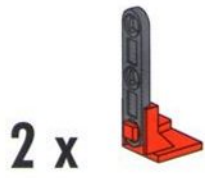
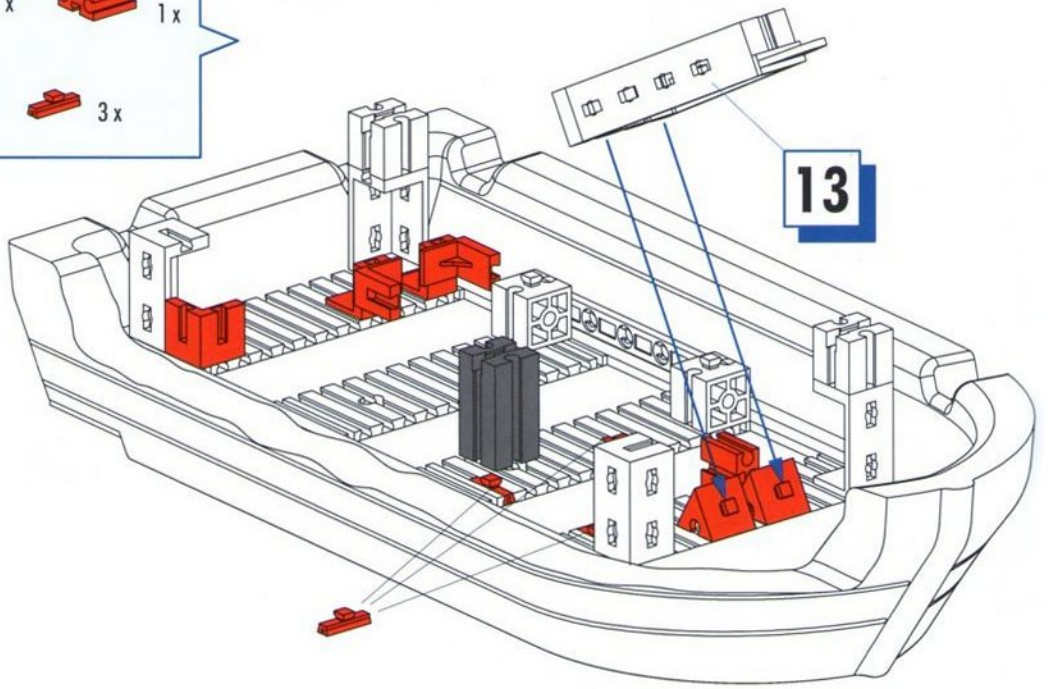
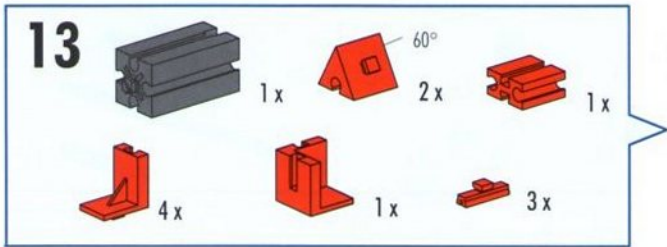

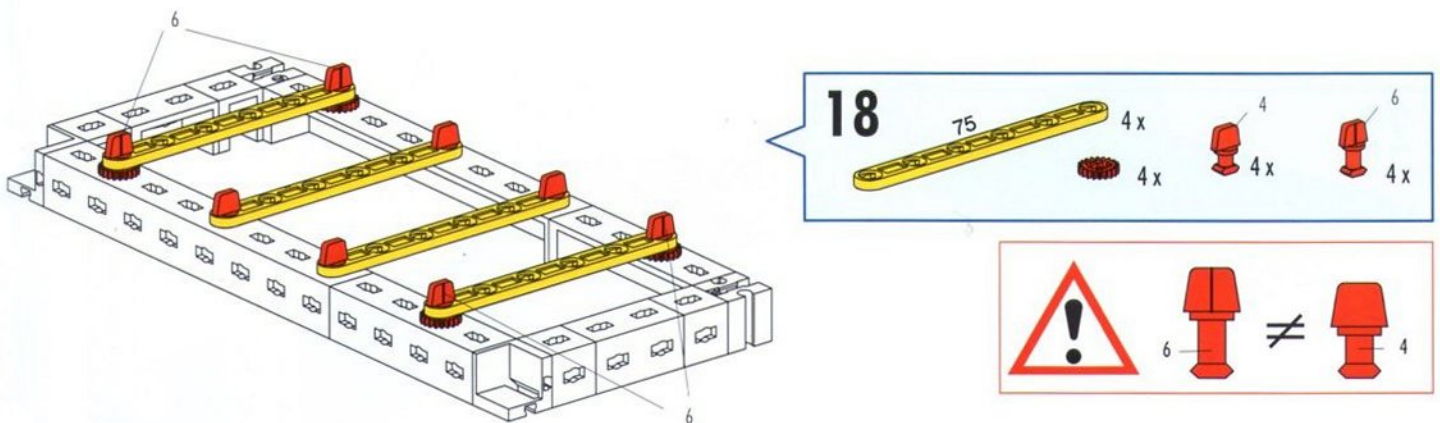
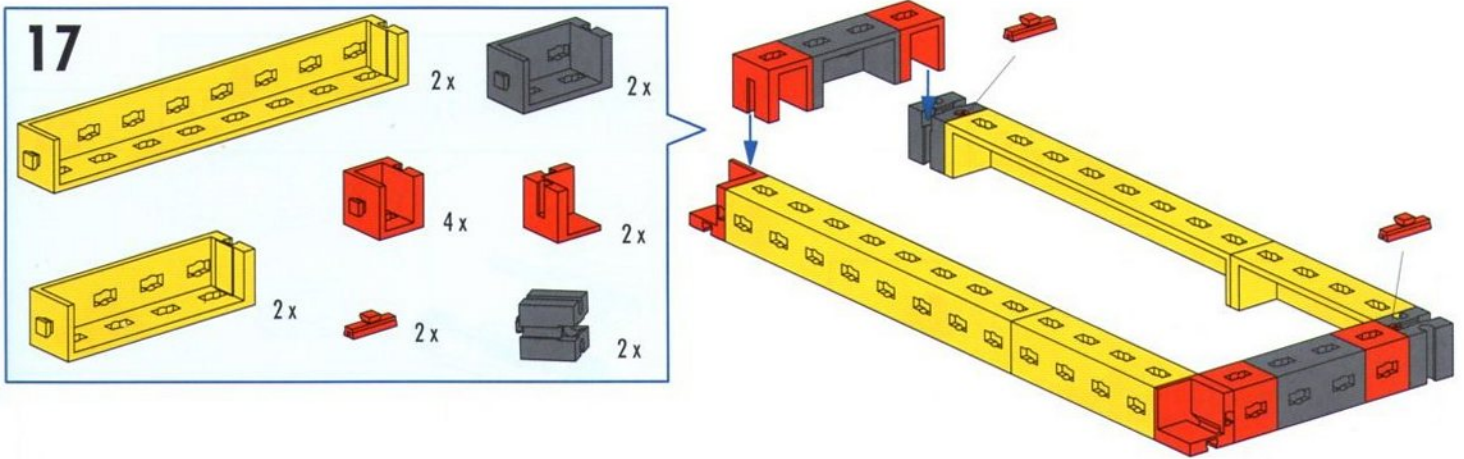
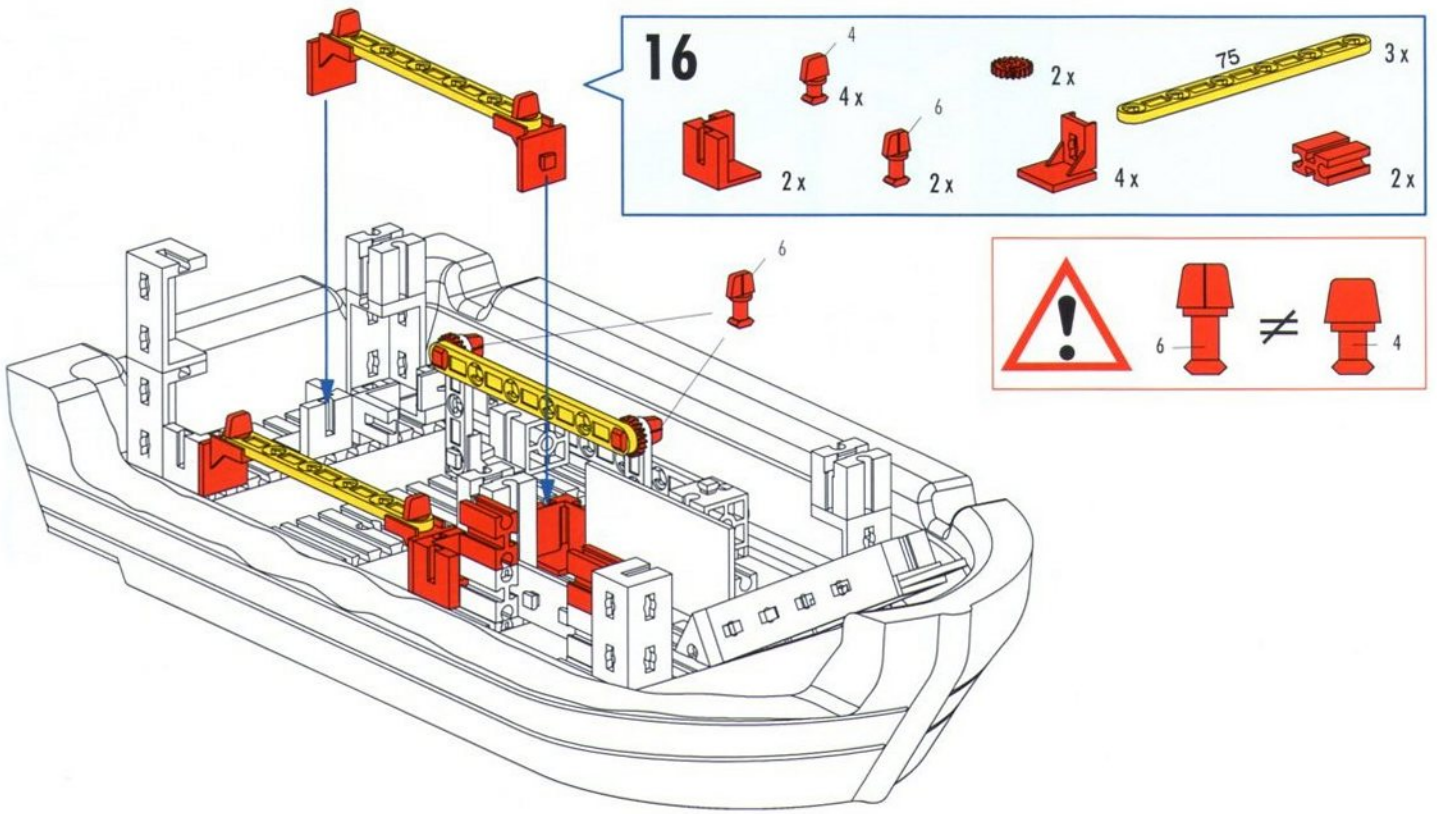

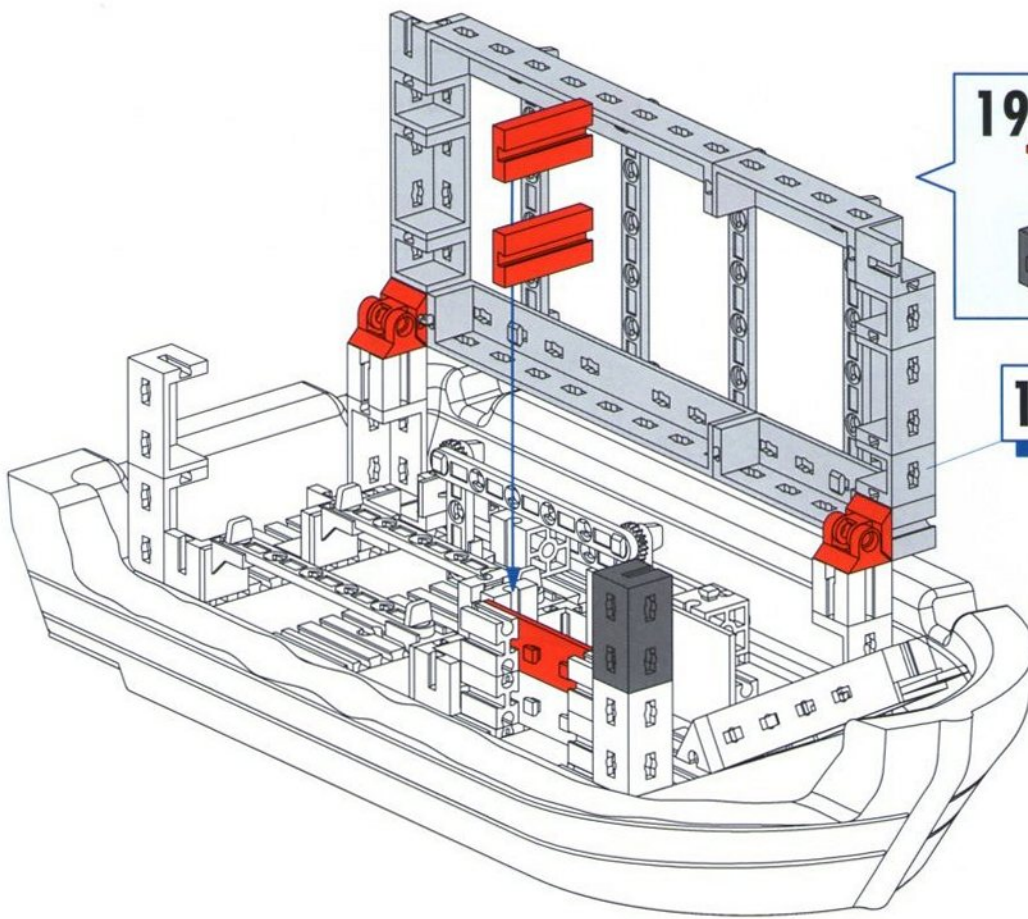

19

- 1x Red Technic 1x3 Beam
- 2x Red Technic 1x2 Connector
- 1x Grey Technic 1x2 Connector
- 2x Red Technic 1x2 Connector

18

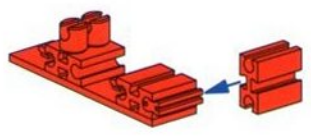

20

- 1x Red Technic 1x3 Beam
- 3x Red Technic 1x2 Connector
- 1x Red Technic 1x5 Beam
- 2x Red Technic 1x2 Connector

21

- 1x Red Technic 1x2 Connector
- 1x Grey Technic Pin
- 2x Grey Technic Pin
- 1x Red Technic 1x2 Connector
- 1x Red Technic 1x2 Connector

50 mm

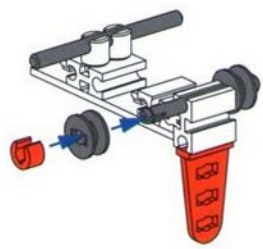

22

- 2x Grey Technic 1x10 Beam
- 2x Red Technic 1x5 Beam
- 12x Yellow Technic 1x2 Connector

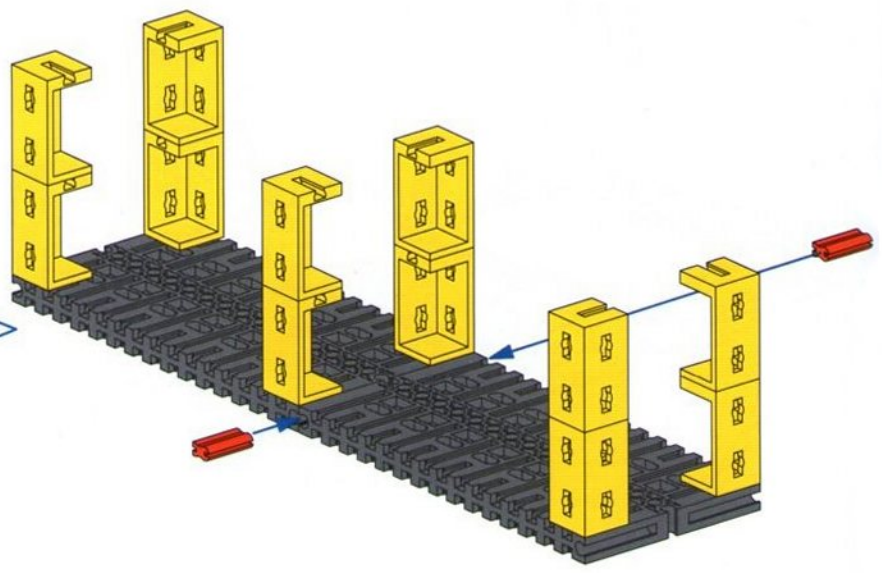

23

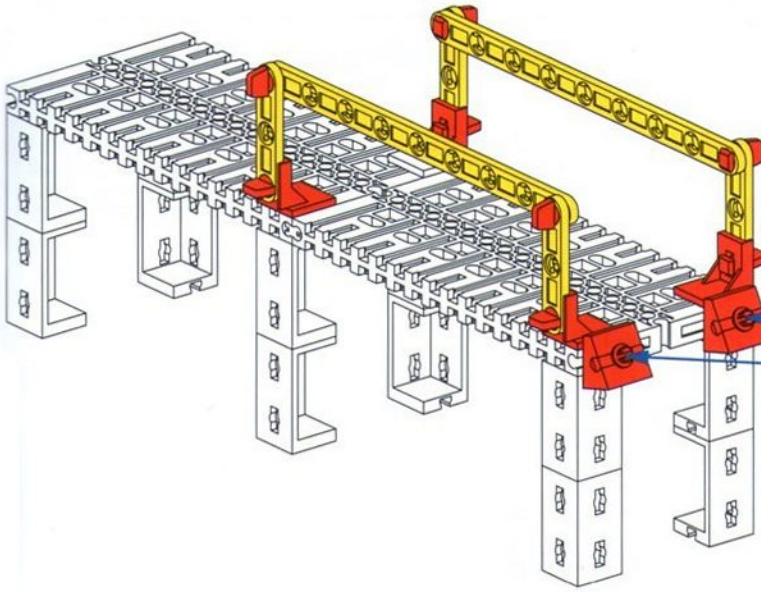
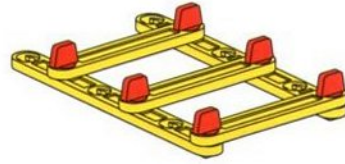
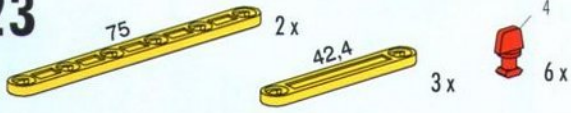

24

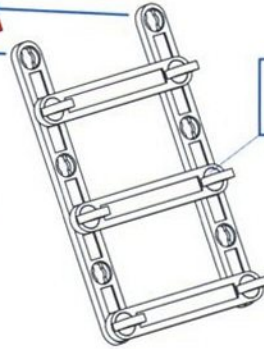
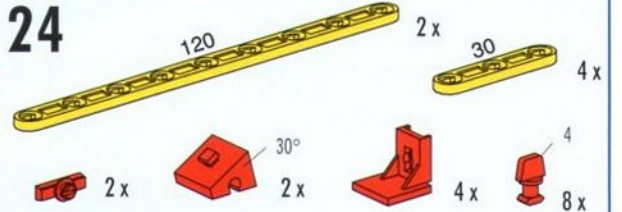

23

25

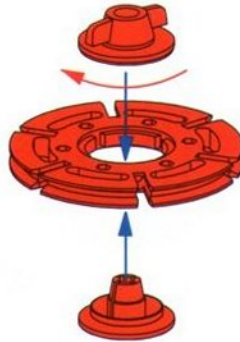
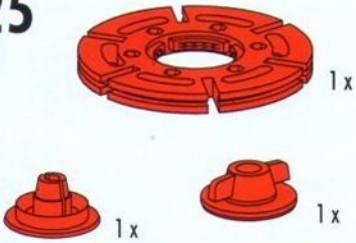

26

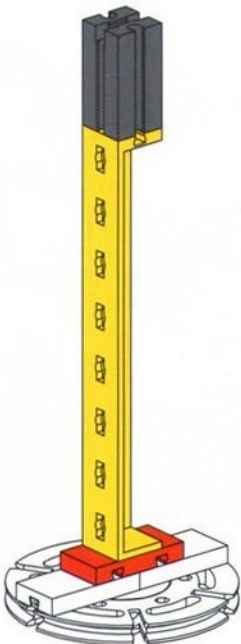
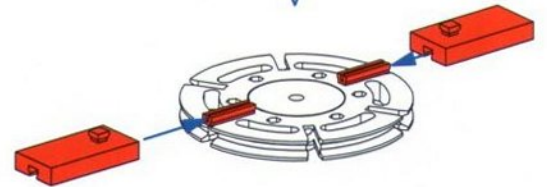



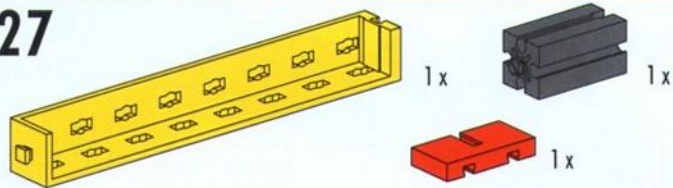

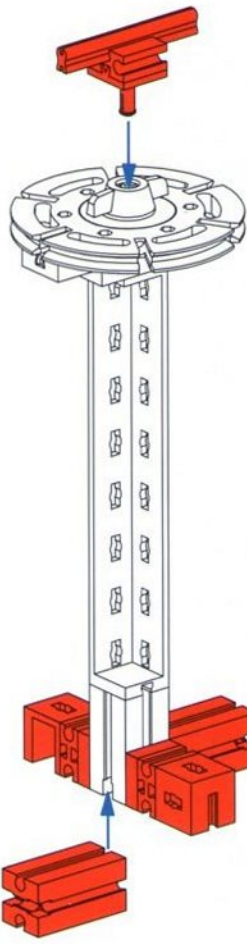

27

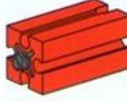



28

 2 x	 2 x	 3 x	 1 x
	 1 x	 2 x	

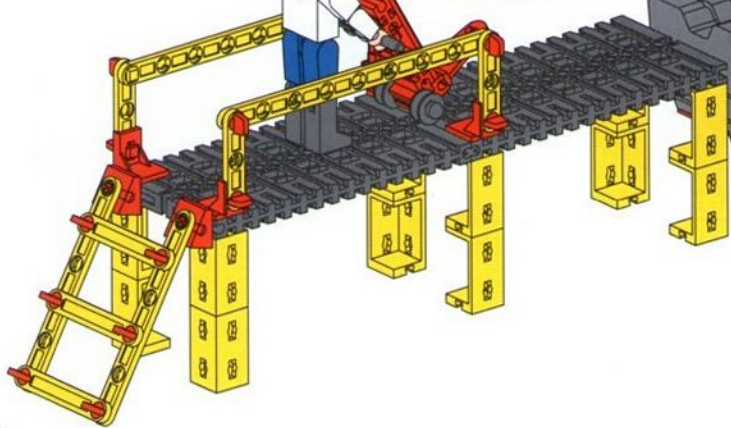
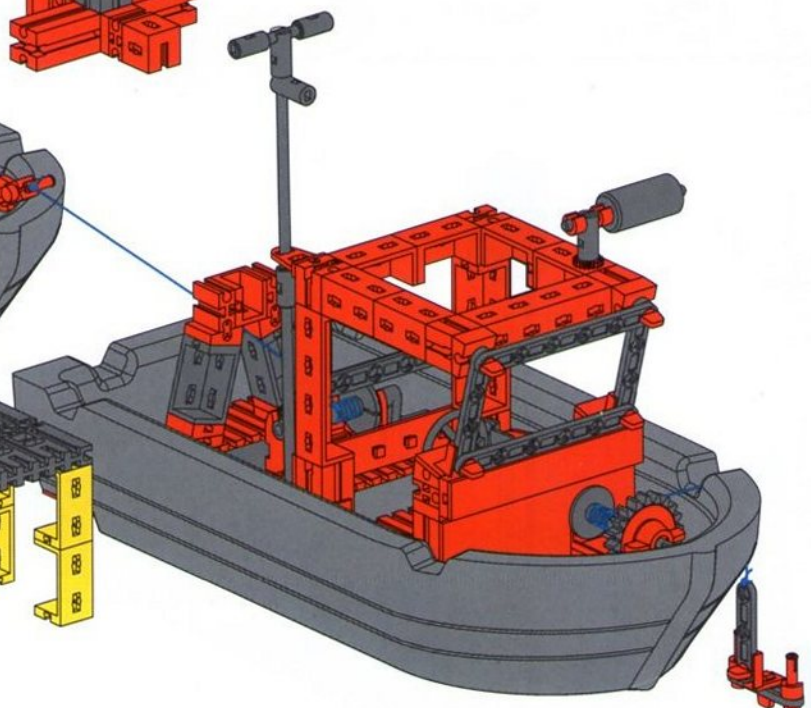
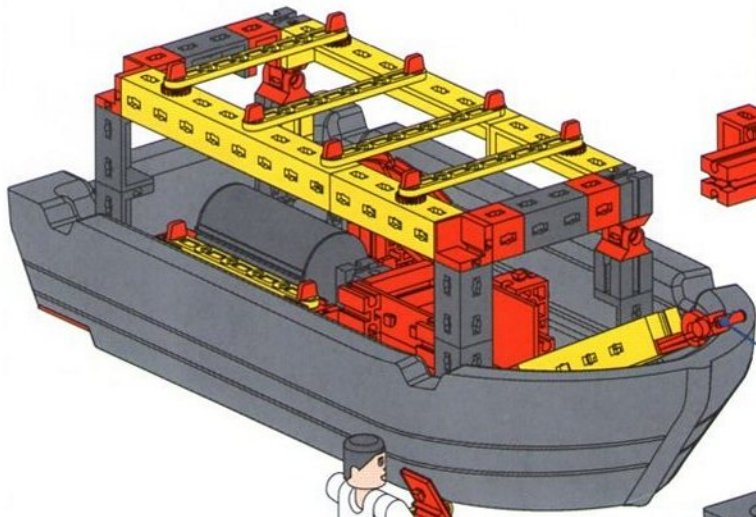
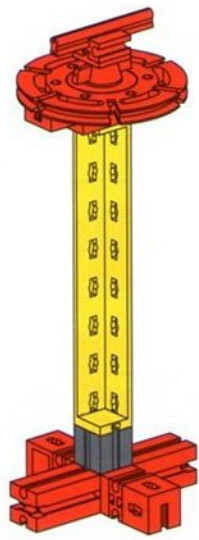

Frachtschiff und Kran
Cargo ship and crane
Cargo et grue

Vrachtschip en kraan
Buque de carga y grúa
Navio de carga e guincho

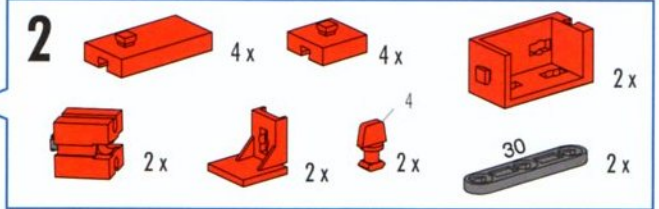
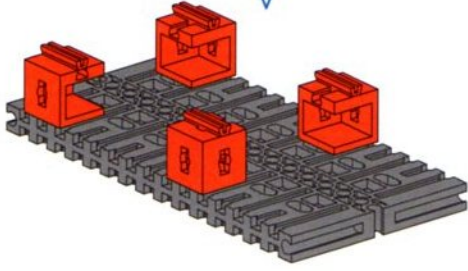
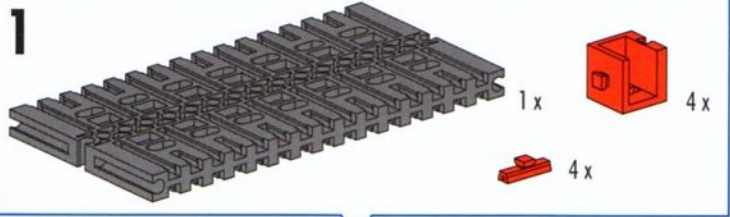
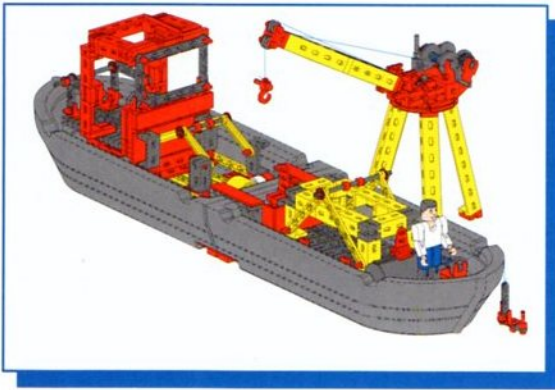

Montagetipps Seite 2
Tips for assembly Page 2
Tuyaux pour le montage page 2
Montagetips zie bladzijde 2
Consejos para el montaje, ver la página 2
"Dicas" para montagem - Página 2

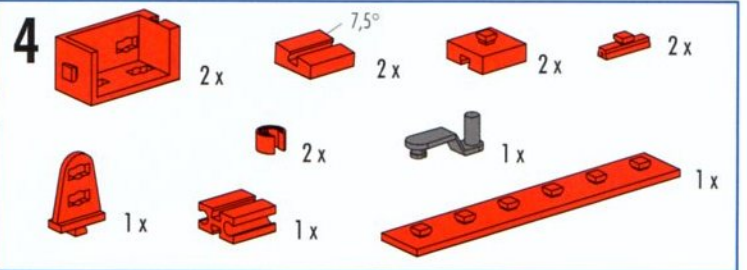
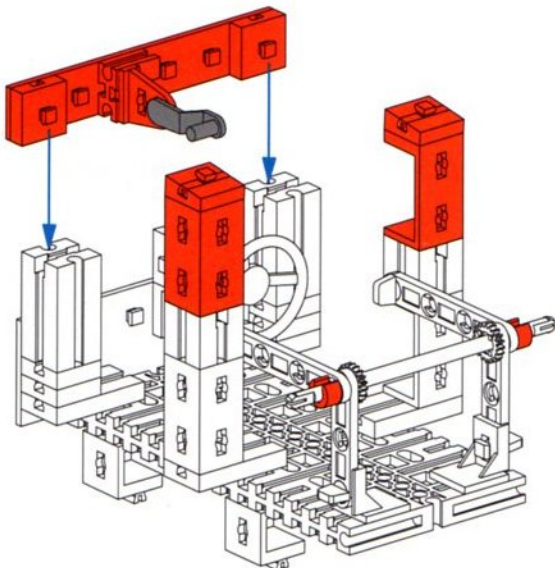
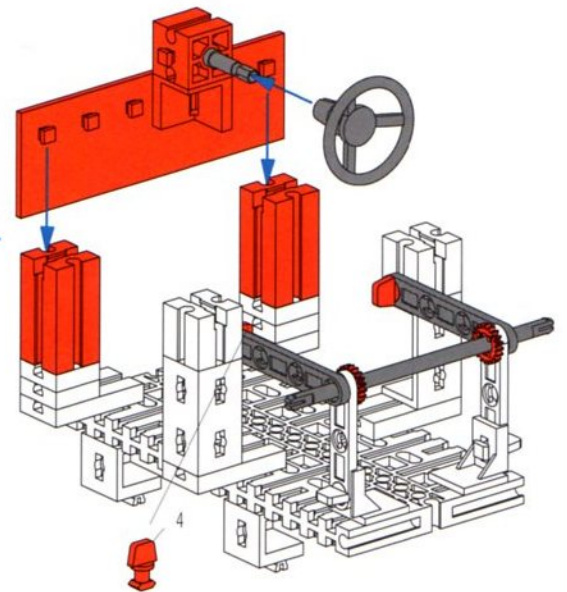
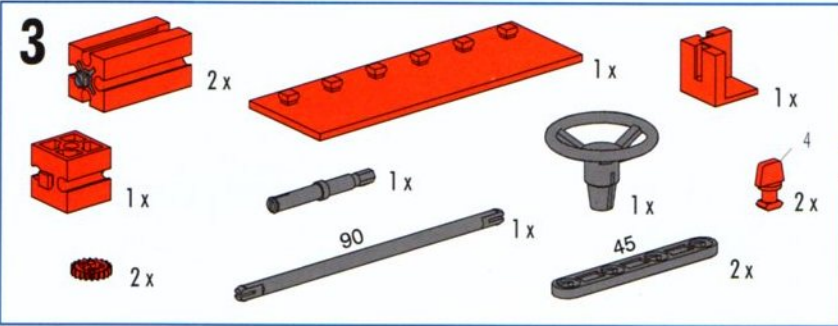
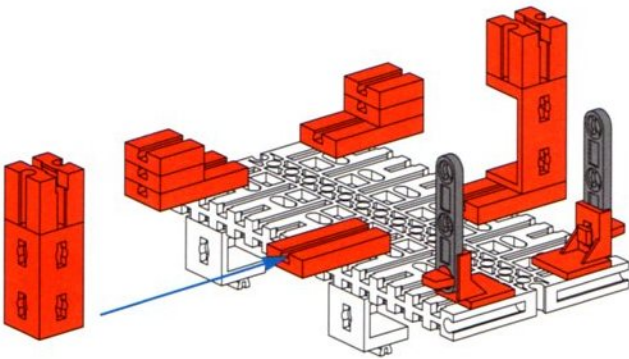

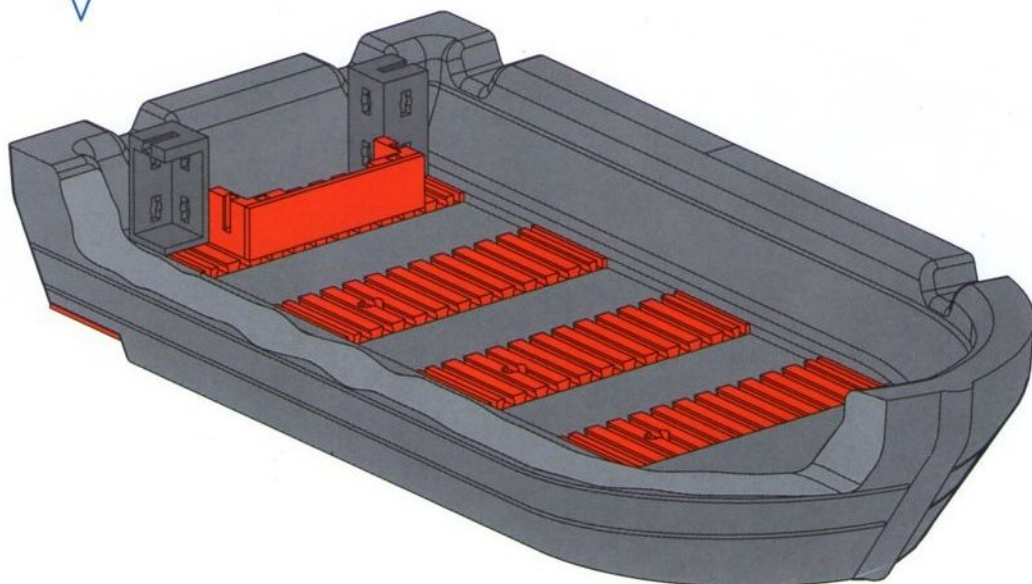
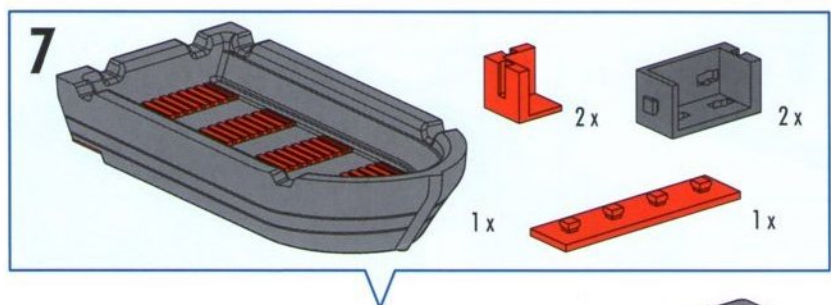
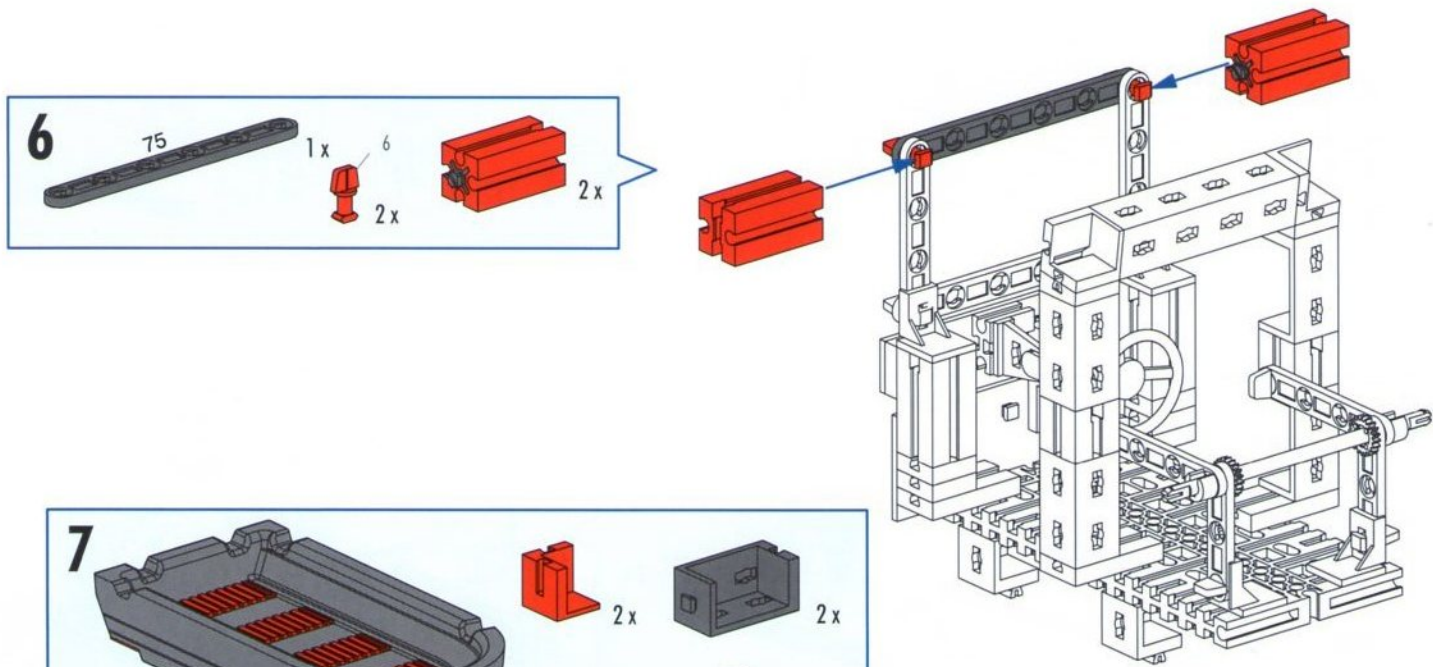
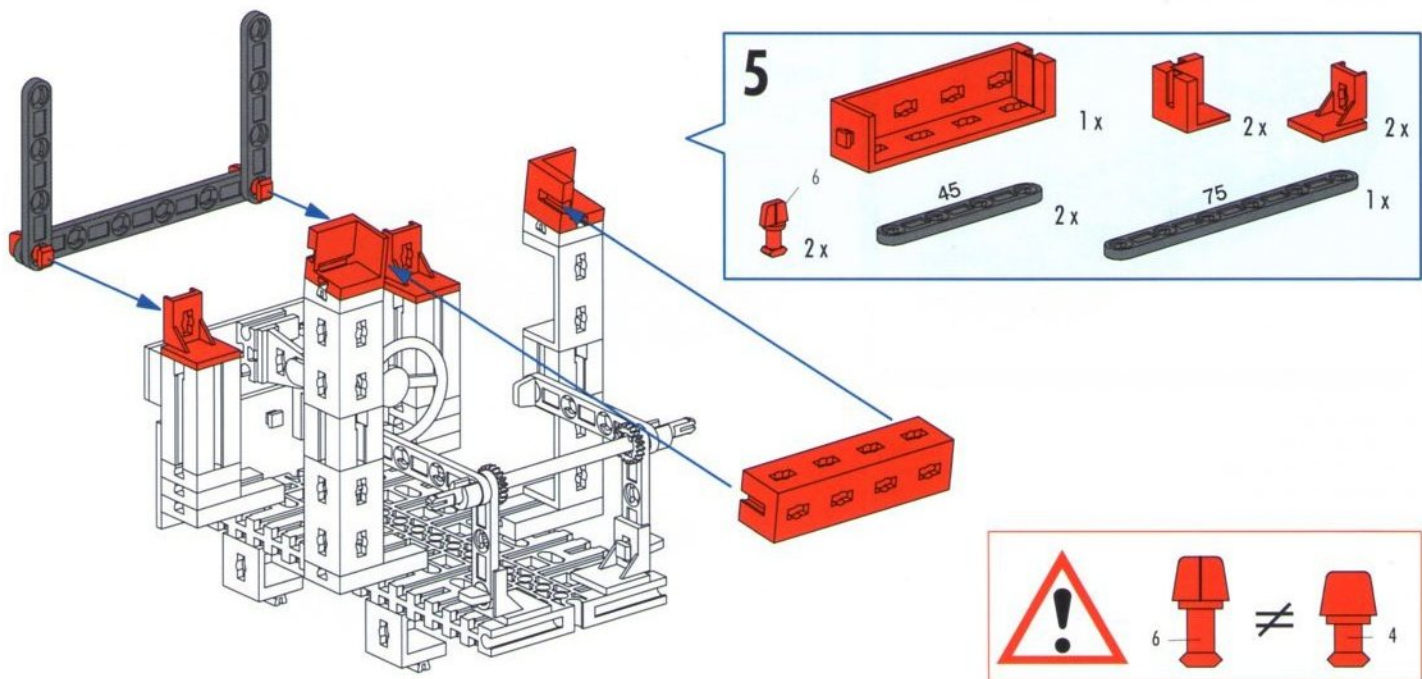

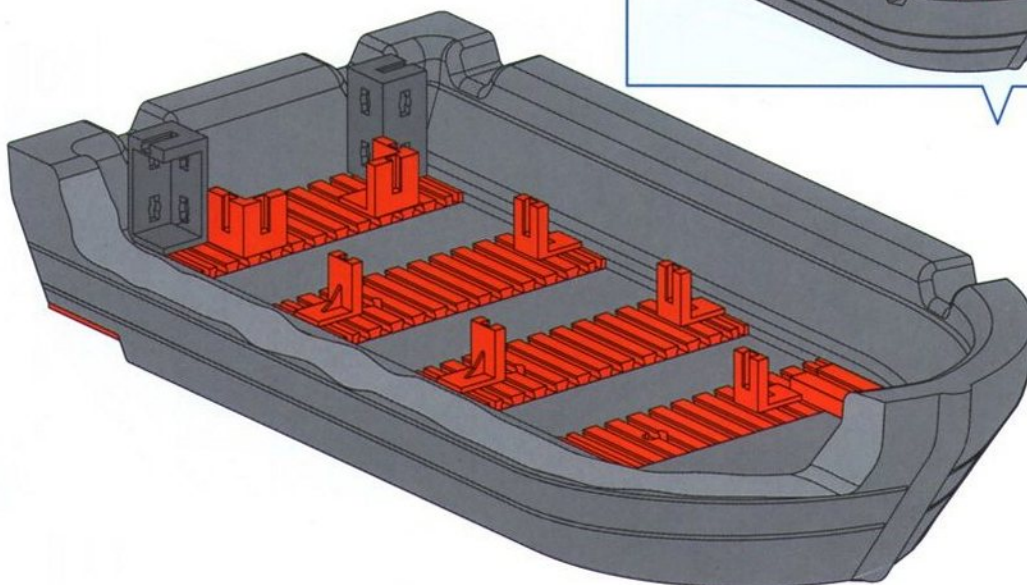
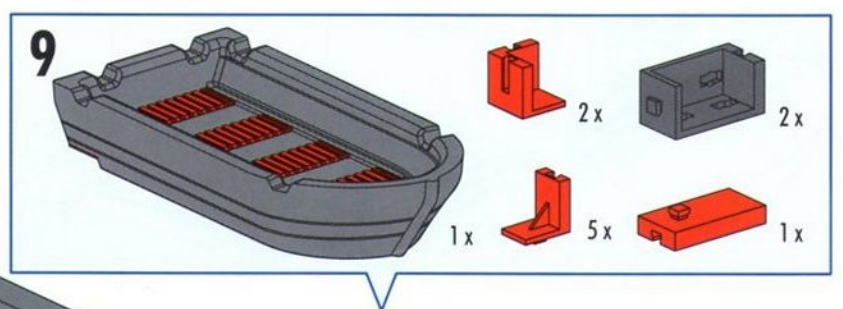
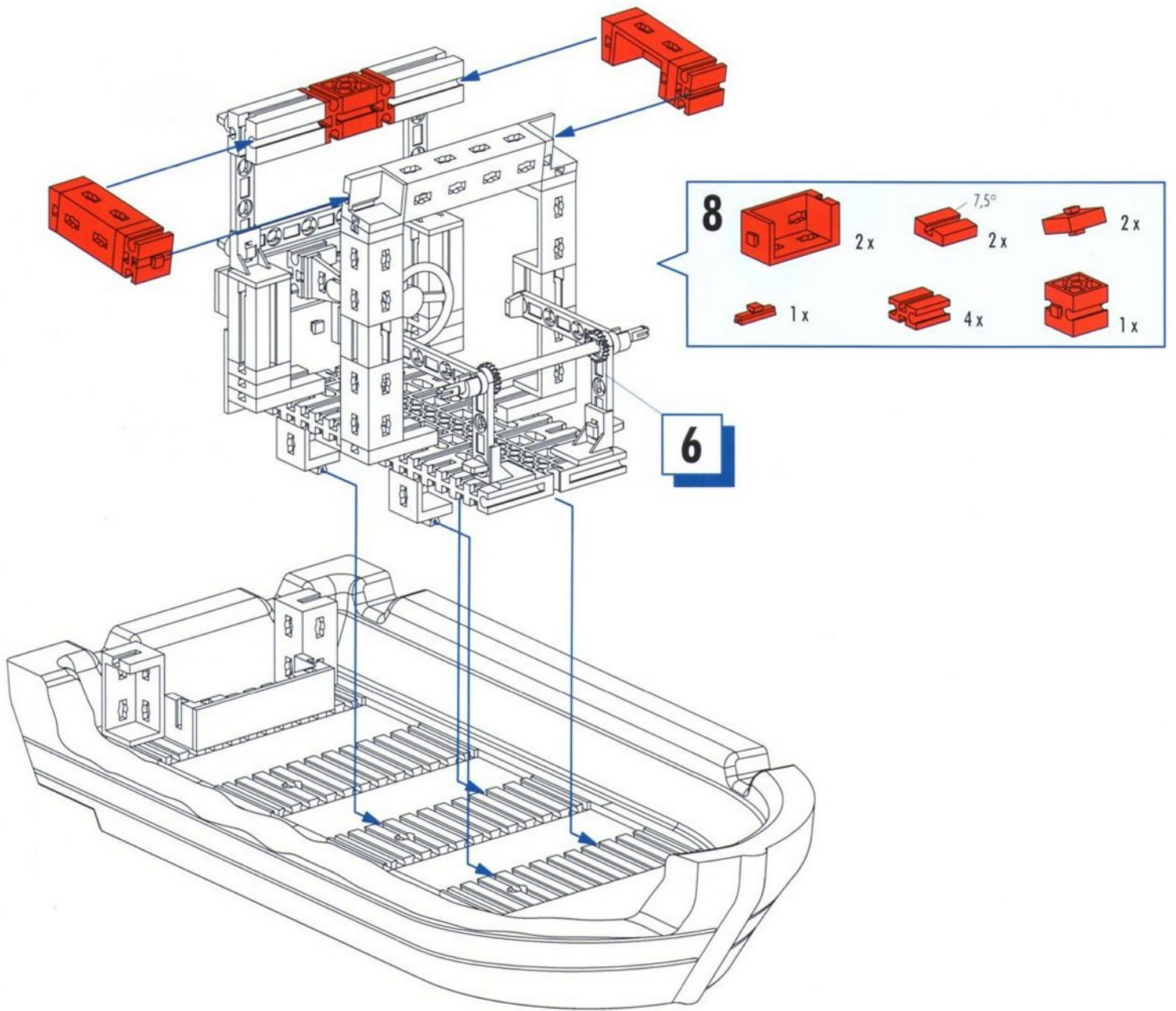

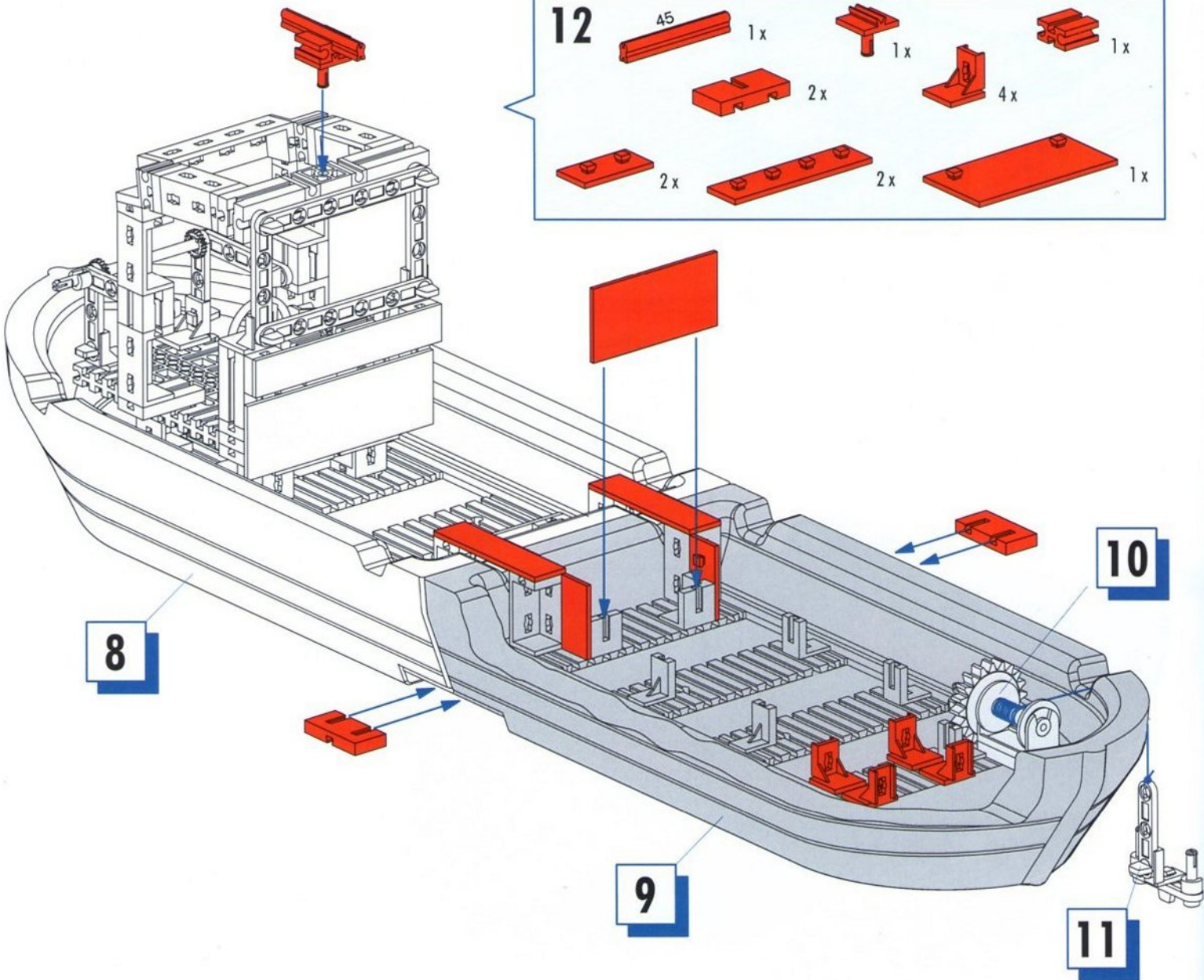
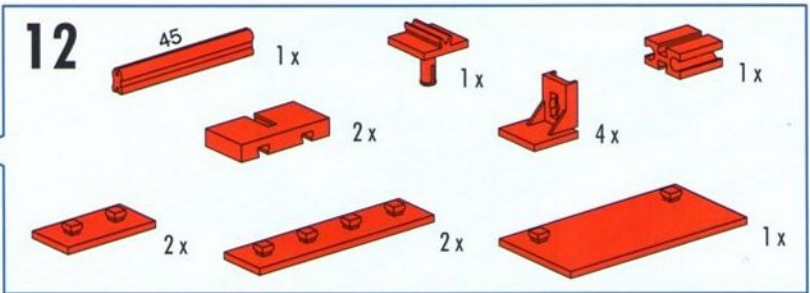
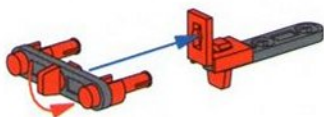
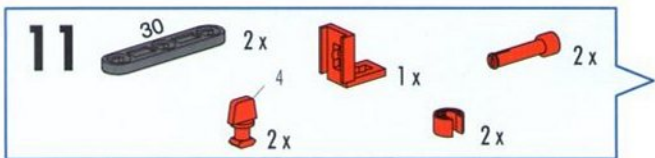
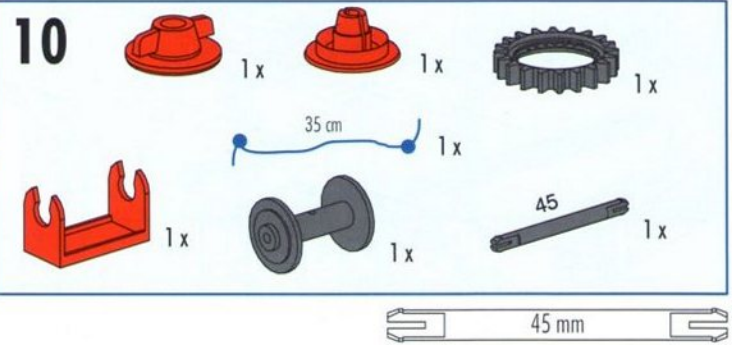

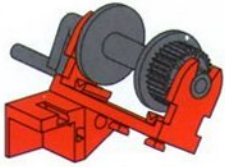

13

1x 60° 1x 1x

14

1x 60° 1x 1x 1x 1x 1x

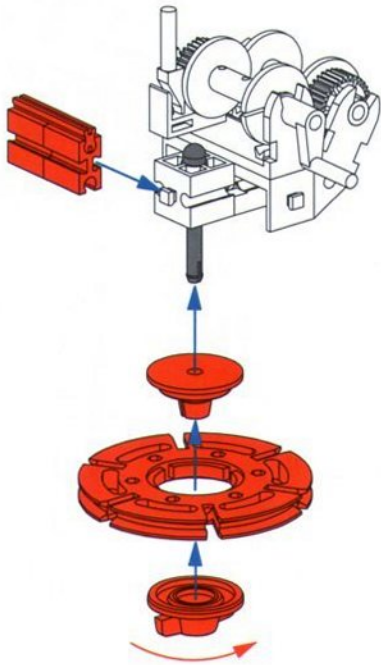
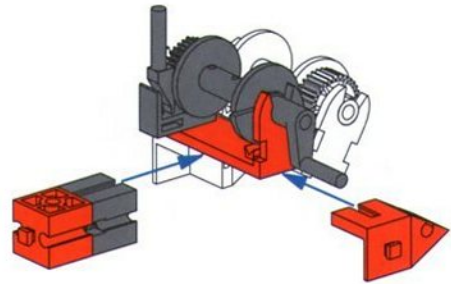

15

1x 1x 1x 30 1x 1x 2x 1x

16

3x 15° 3x 2x 1x 30 1x 2x 2x

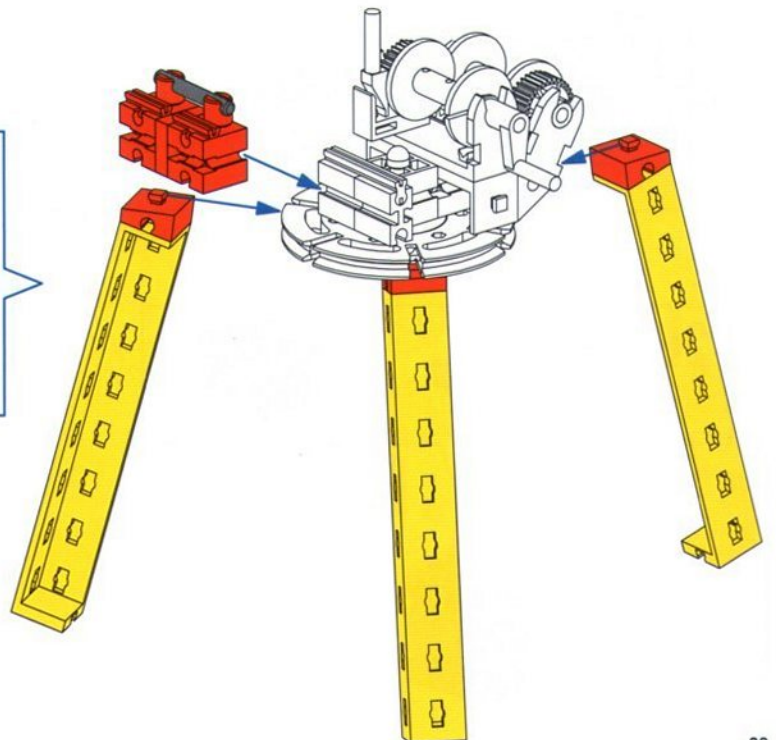

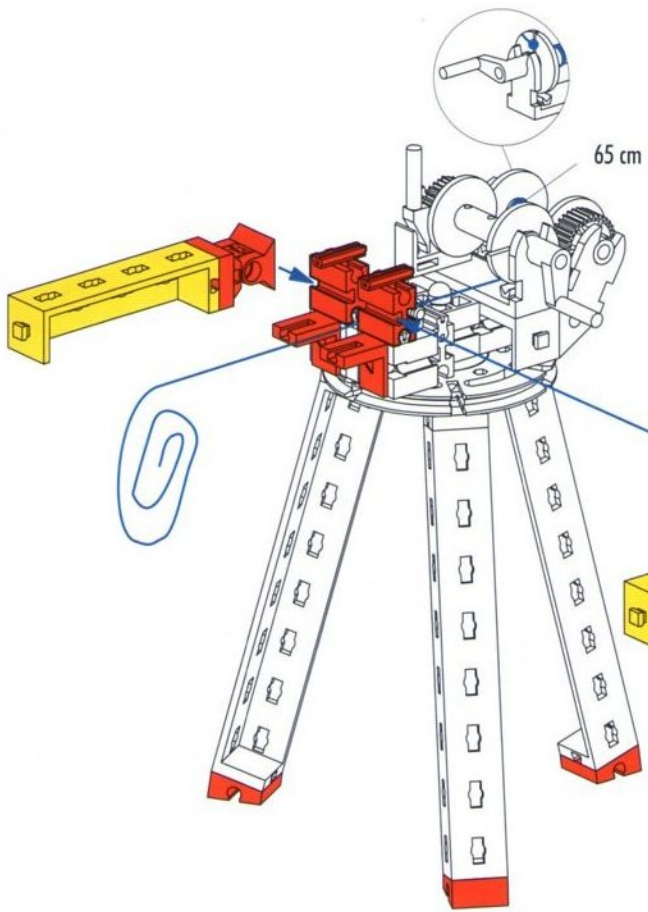

17

- Yellow Technic beam (15 holes) 2x
- Red Technic connector (1 hole) 2x
- Red Technic connector (2 holes) 2x
- Red Technic connector (1 hole, 15°) 3x
- Red Technic connector (1 hole, 15°) 2x
- Red Technic connector (2 holes) 2x
- Red Technic connector (1 hole) 2x
- Red Technic connector (1 hole) 1x

65 cm

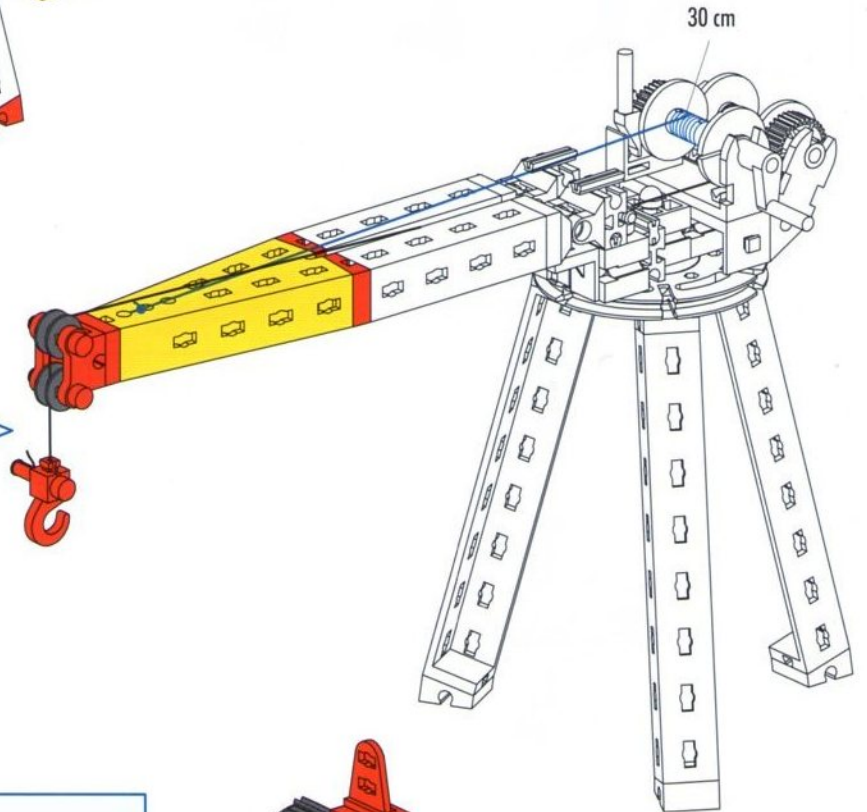
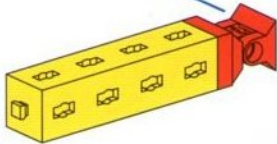

18

- Yellow Technic beam (15 holes) 1x
- Red Technic connector (1 hole) 1x
- Red Technic connector (1 hole) 1x
- Red Technic connector (1 hole, 7.5°) 2x
- Red Technic connector (1 hole) 1x
- Red Technic connector (2 holes) 1x
- Red Technic connector (1 hole) 1x
- Red Technic connector (1 hole) 3x
- Black Technic bush (1 hole) 2x

30 cm

7.5°



19

- Black Technic bush (1 hole) 1x
- Red Technic connector (2 holes) 1x
- Red Technic connector (1 hole) 1x



20

- Red Technic connector (1 hole) 1x
- Red Technic connector (1 hole) 2x
- Black Technic bush (1 hole) 2x

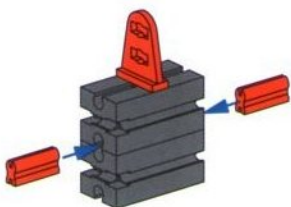

21

- Red Technic connector (1 hole) 1x
- Red Technic connector (1 hole) 2x
- Red Technic connector (2 holes) 2x

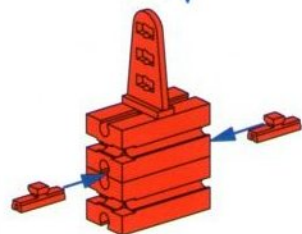

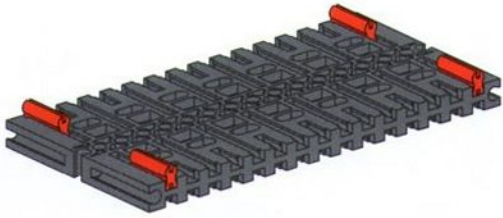

22

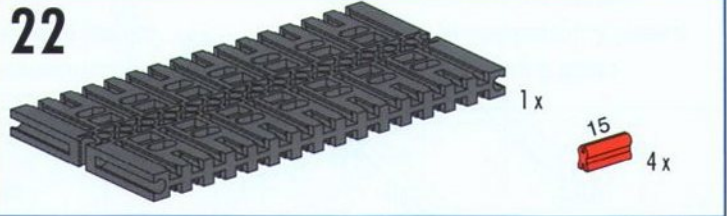

23

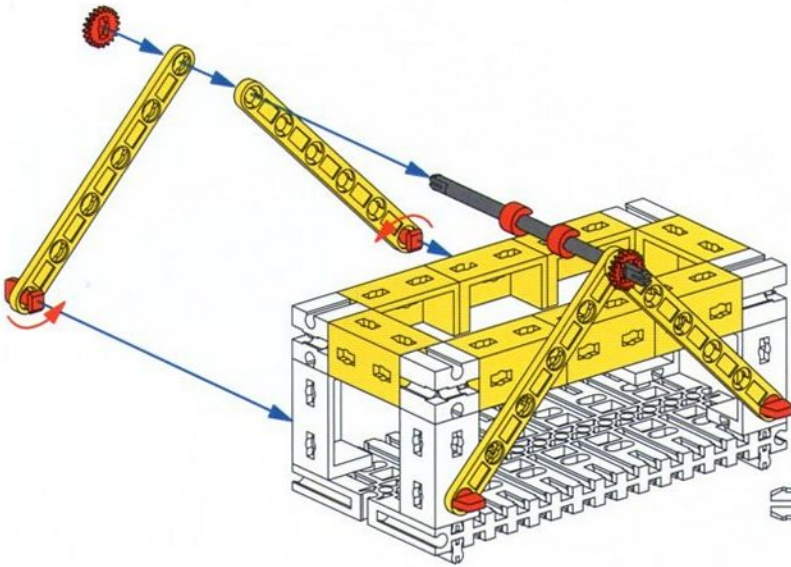
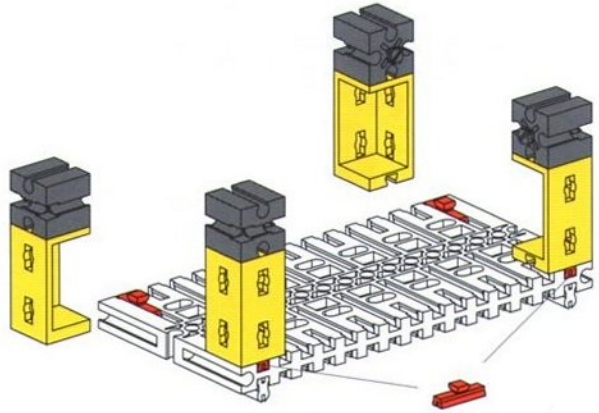
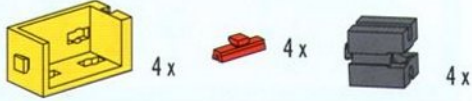

24

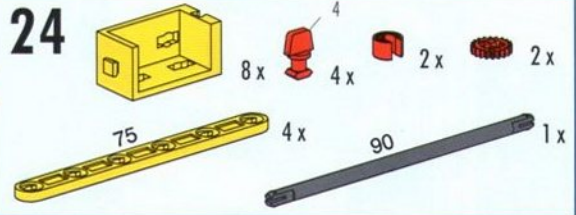

25

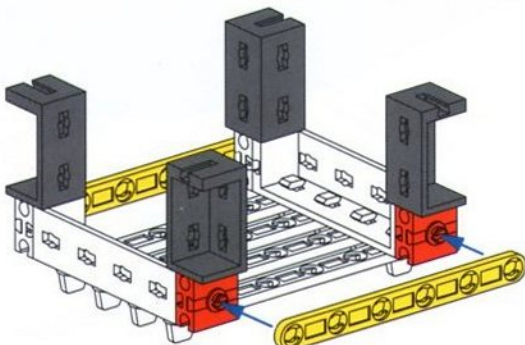
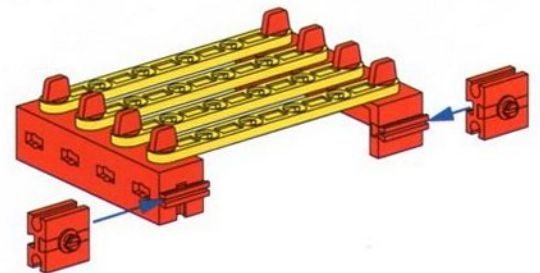
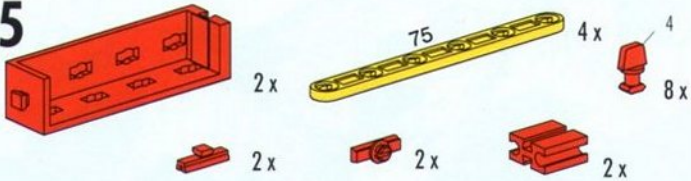

26

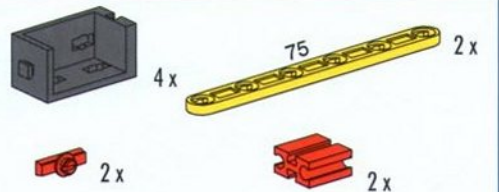

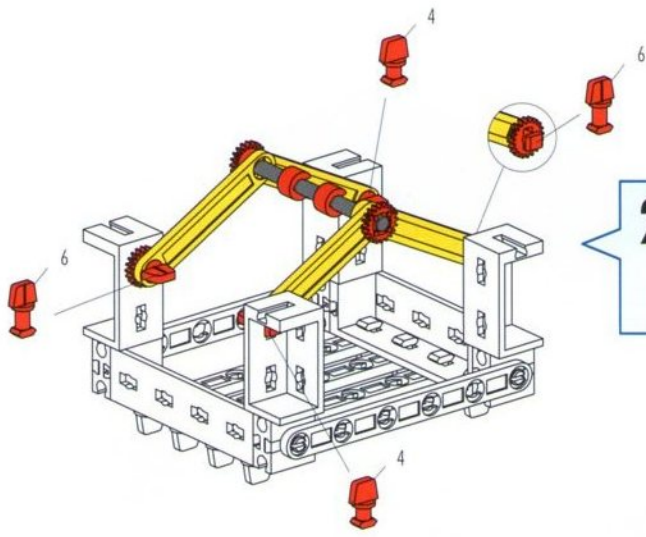

27

60 1x

42,4 4x

2x

4x

4 2x

6 2x

60 mm

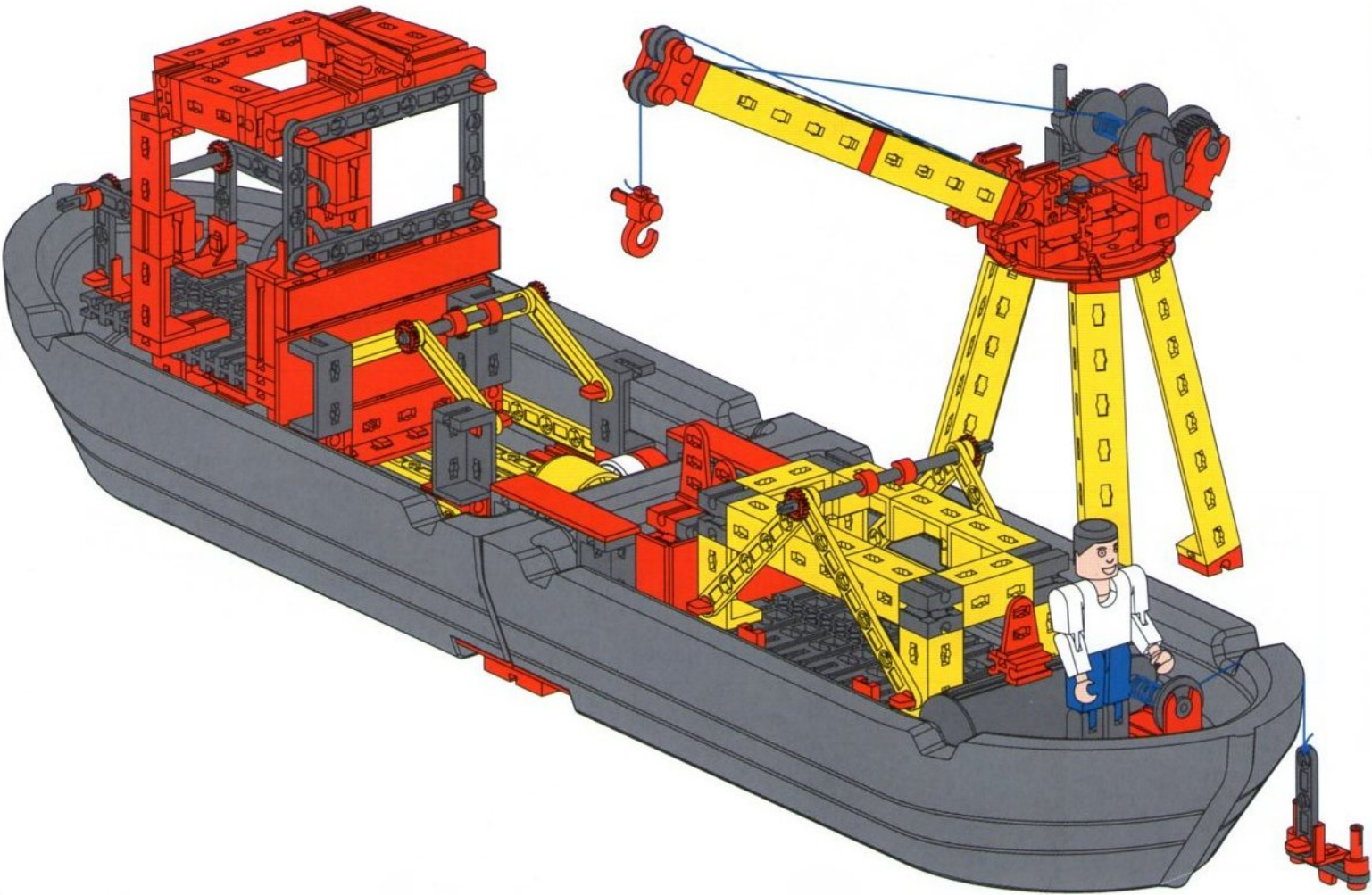
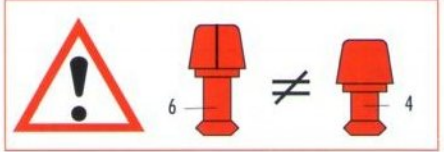

Forschungsschiff und Hafen
 Research ship and harbor
 Bâtiment océanographique et port

Onderzoeksschip en haven
 Buque de investigación y puerto
 Navio de pesquisa e porto

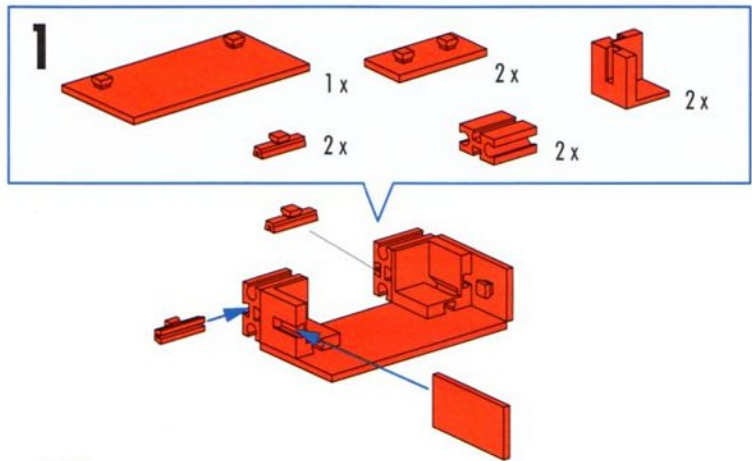
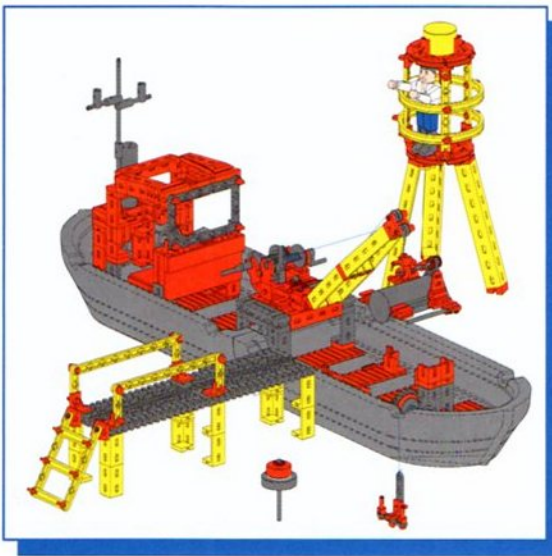

Montagetipps Seite 2
 Tips for assembly Page 2
 Tuyaux pour le montage page 2
 Montagetips zie bladzijde 2
 Consejos para el montaje, ver la página 2
 "Dicas" para montagem - Página 2

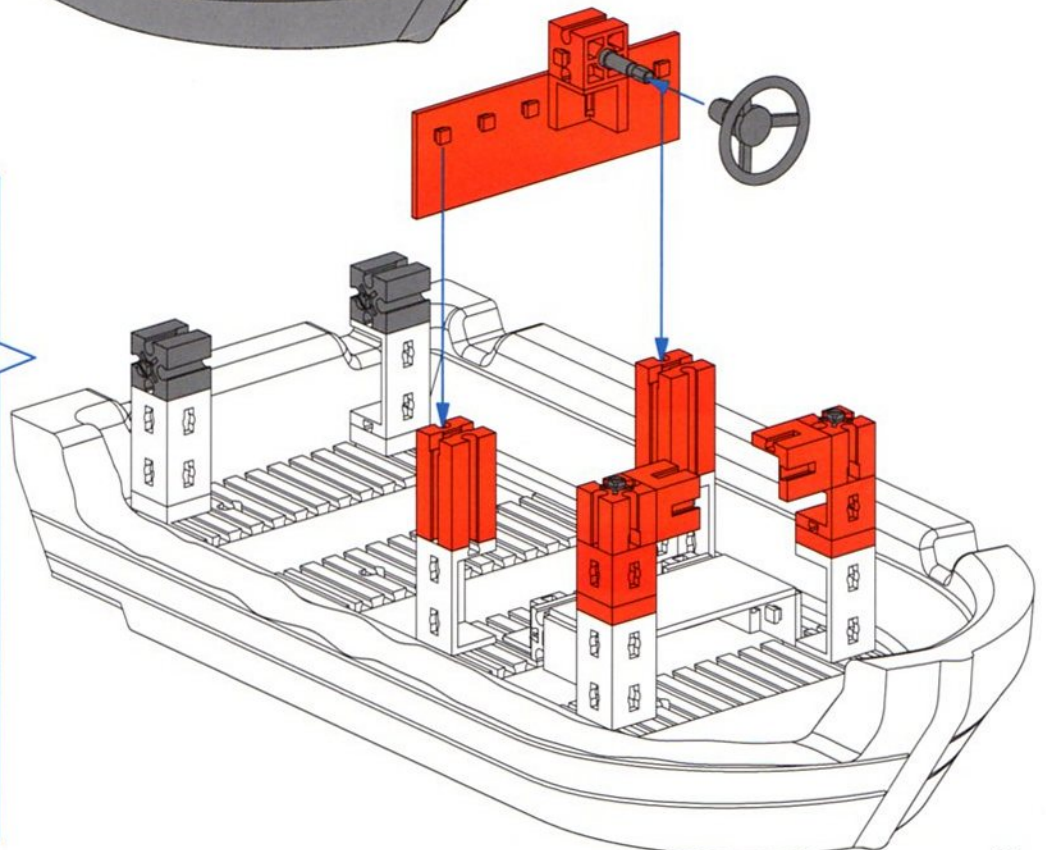
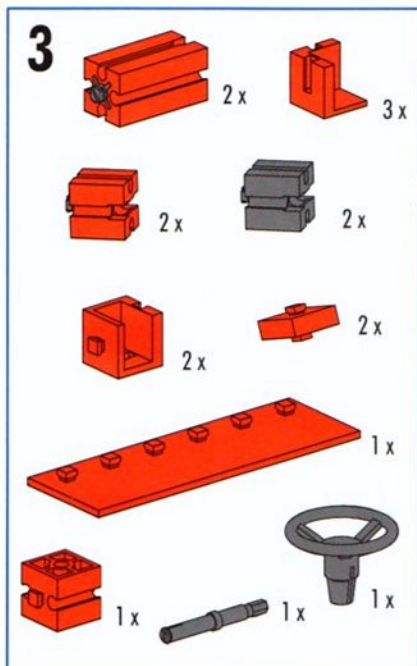
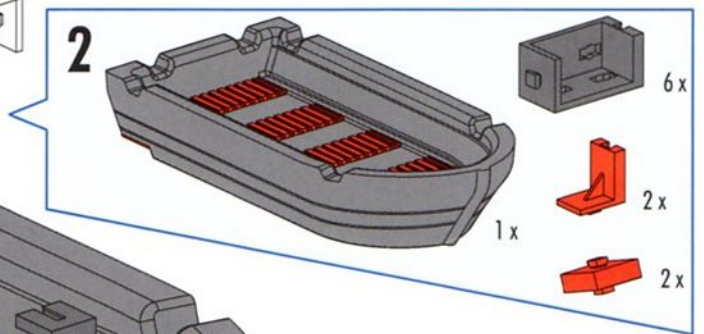
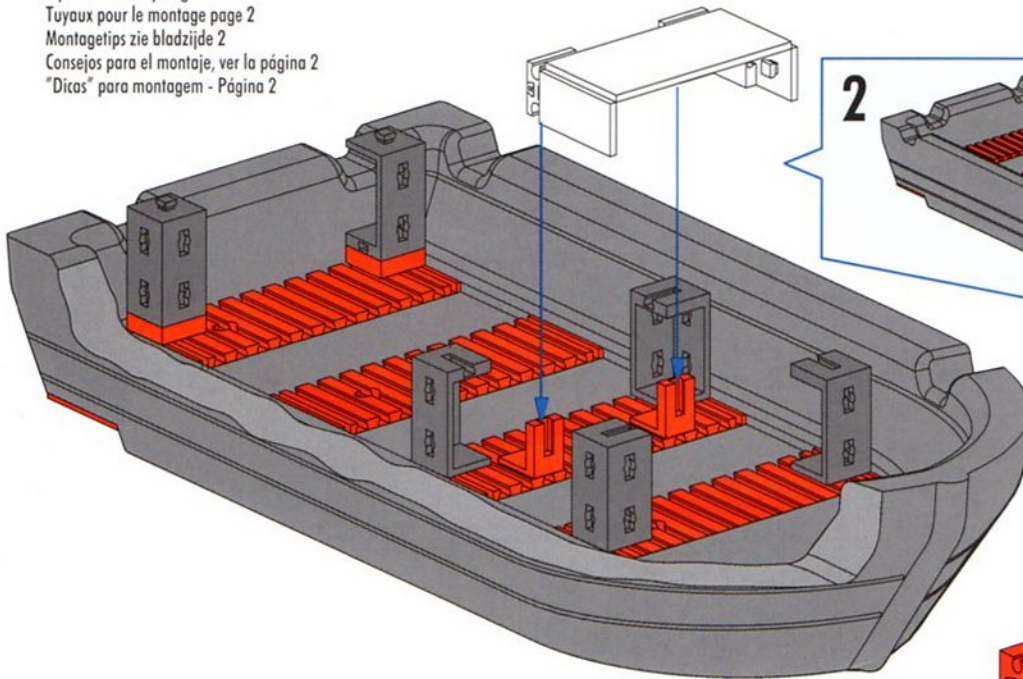

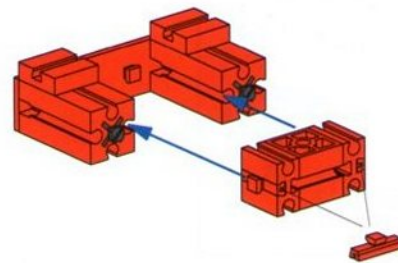
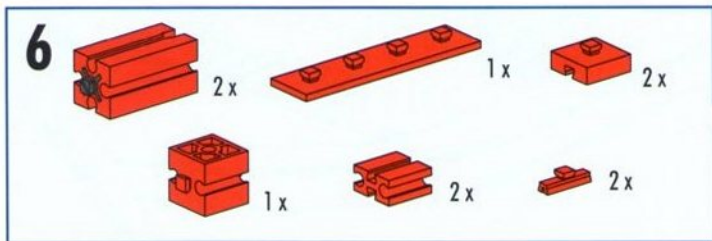
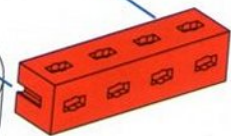
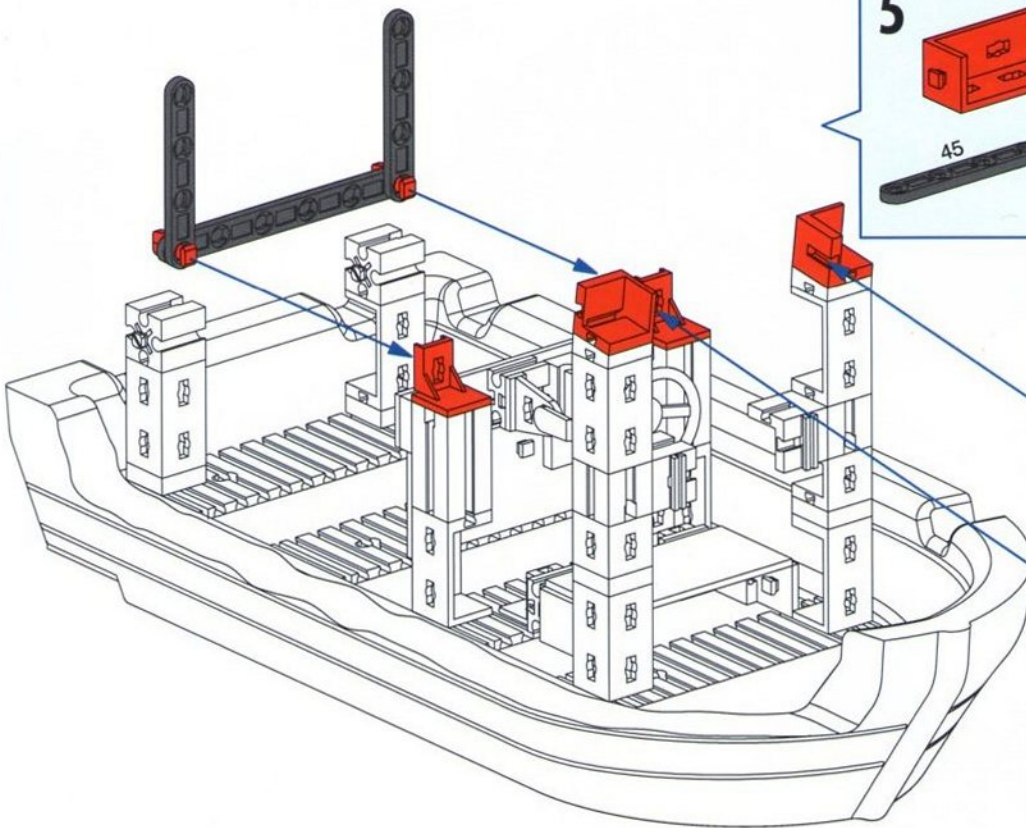
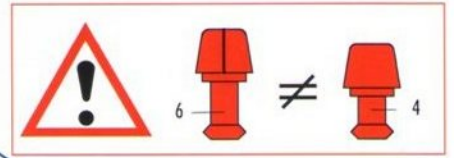
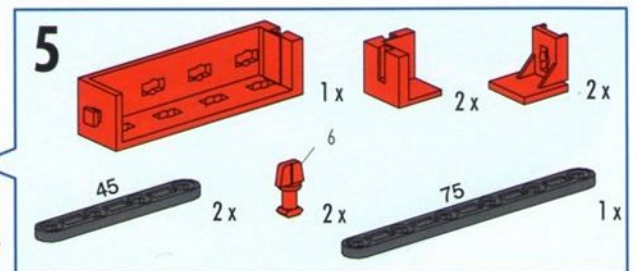
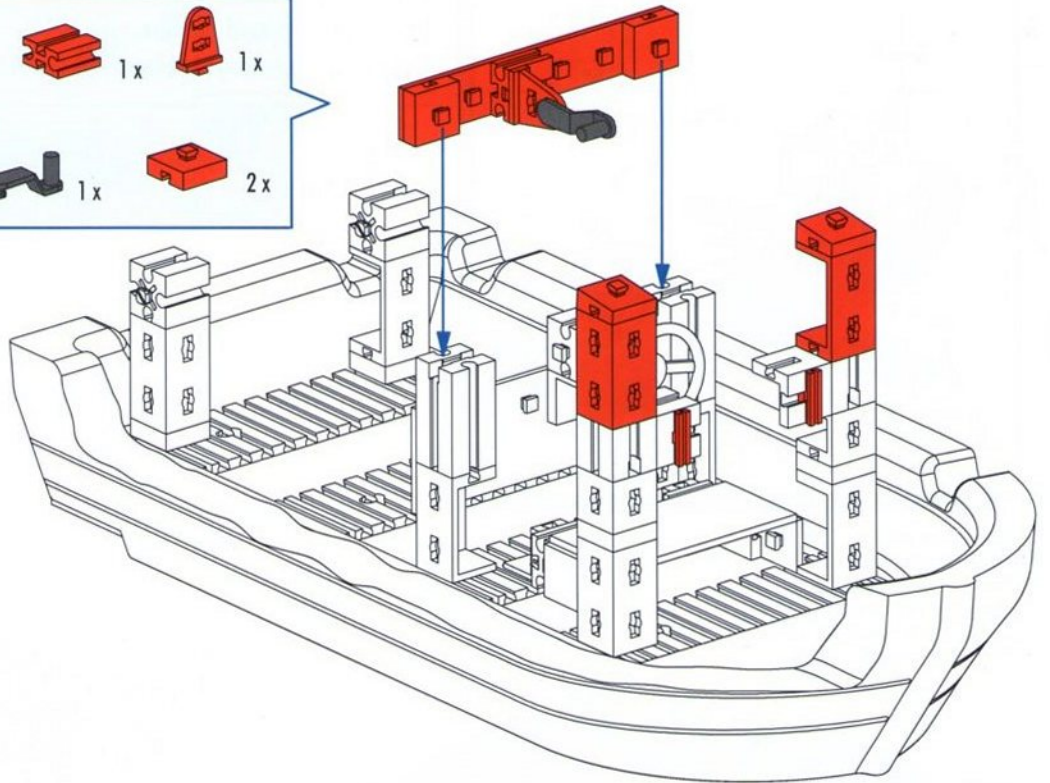
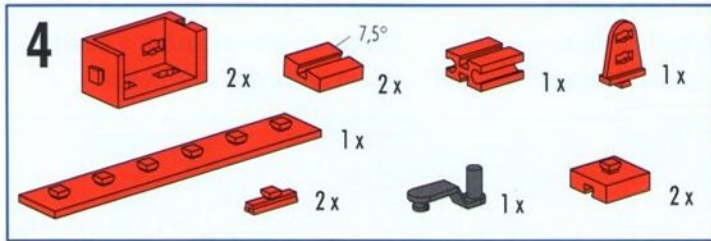

7

90 1x 1x 2x 2x 2x

90 mm

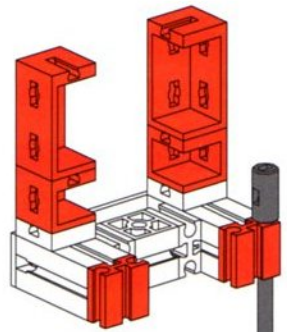

8

2x 75 1x 6 1x 2x

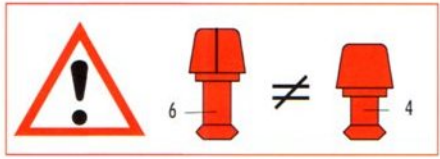
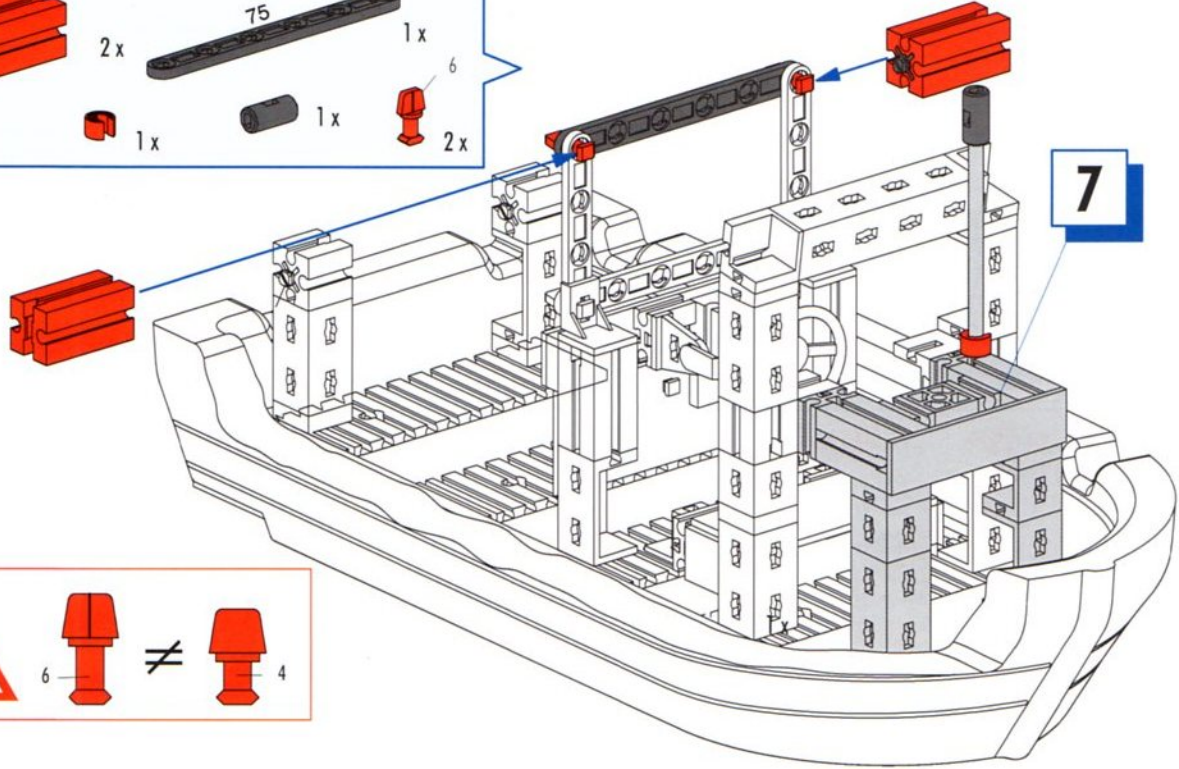

9

2x 2x 2x 2x 2x 1x 2x 90 1x 30 2x 2x 1x 2x 7,5°

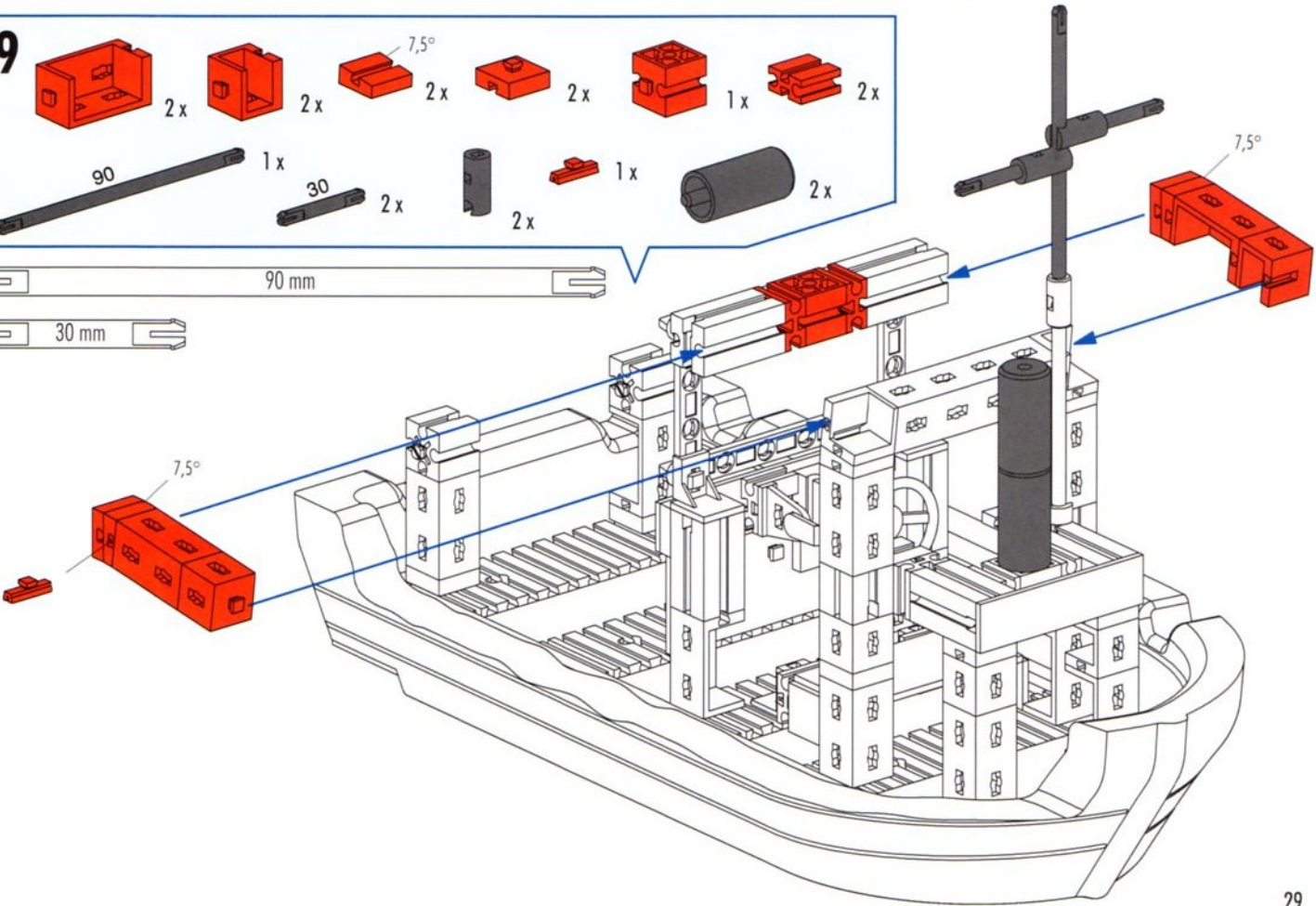
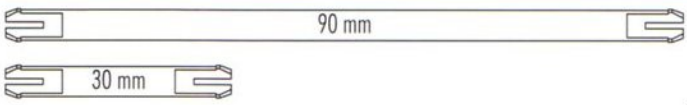

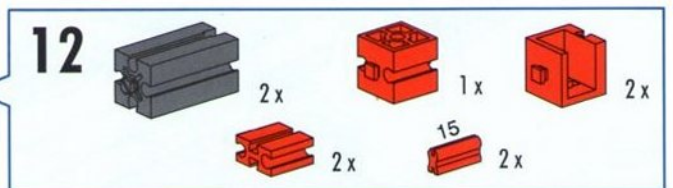
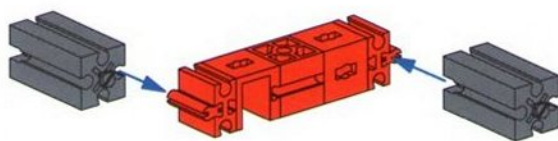
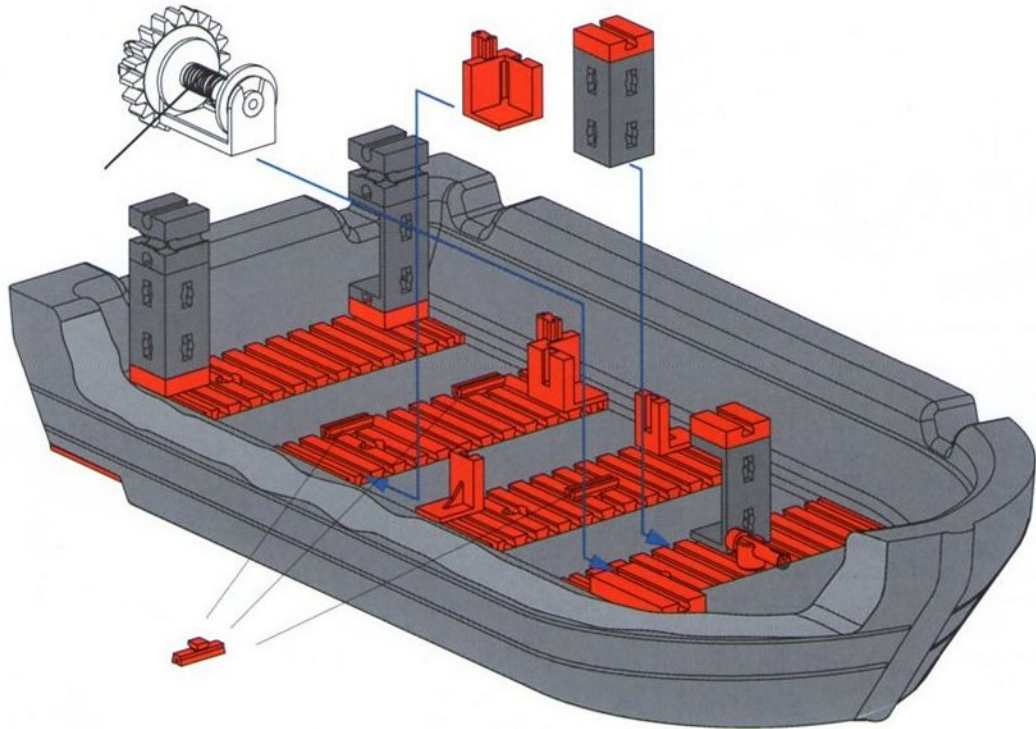
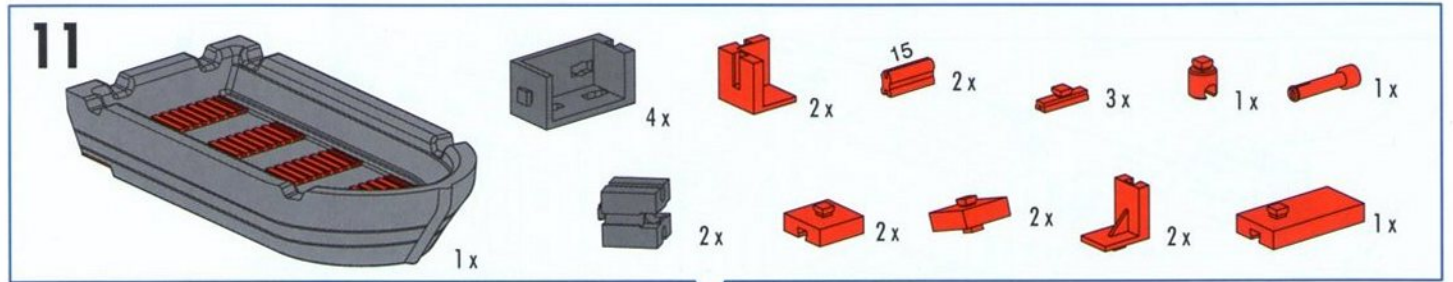
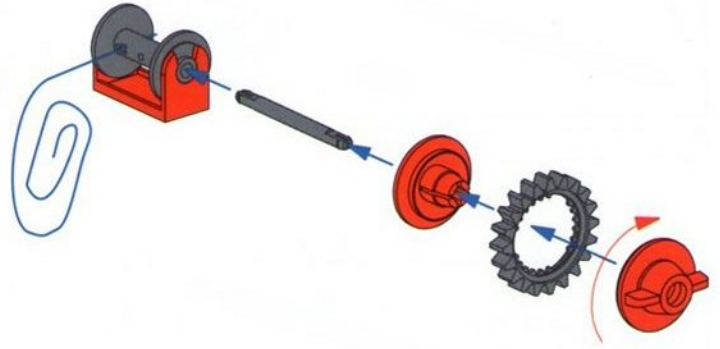
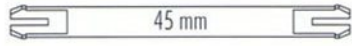
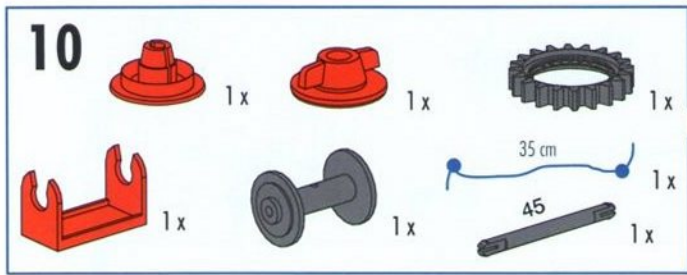

13

- 30 2x
- 4
- 2x
- 1x
- 2x
- 2x

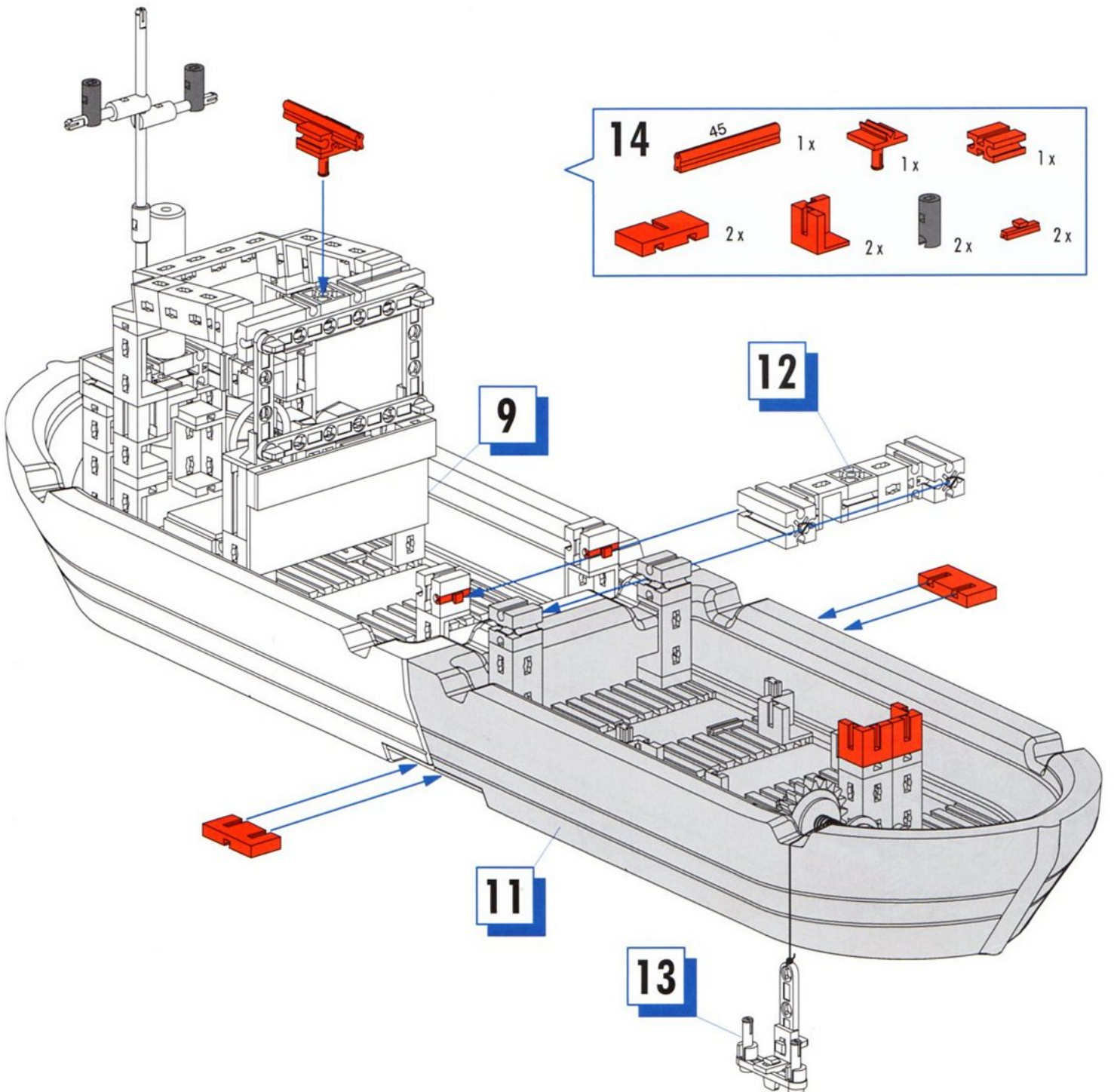
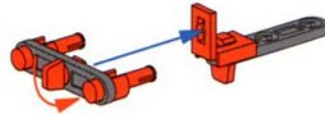

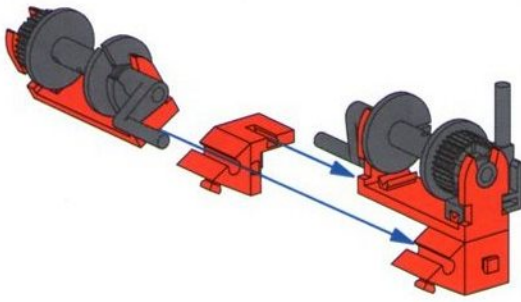

15

2 x 1 x 60° 2 x

16

1 x 2 x 1 x

30 1 x 1 x 2 x

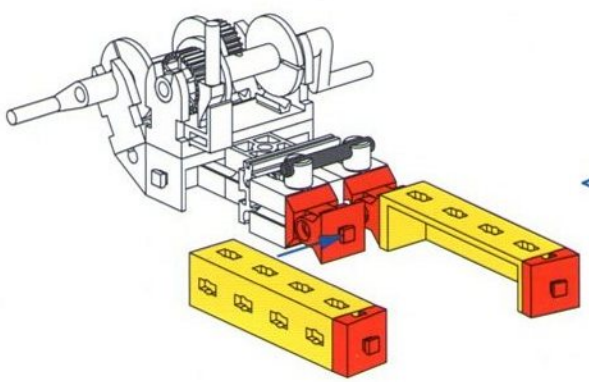
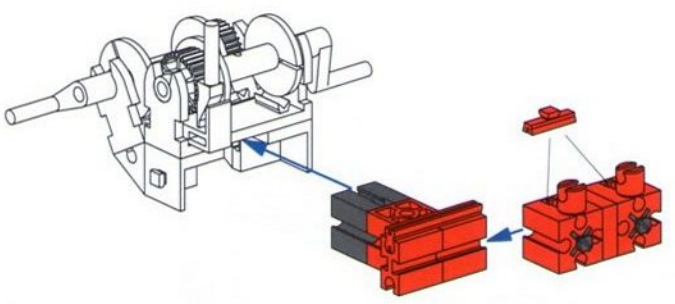

17

2 x 2 x 7,5° 2 x 30 1 x

30 mm

18

- 1 x Yellow Technic Beam (11 holes)
- 2 x Black Technic Washers
- 2 x Red Technic Pins
- 1 x Blue String (30 cm)
- 1 x Red Technic Pin
- 1 x Red Technic Connector

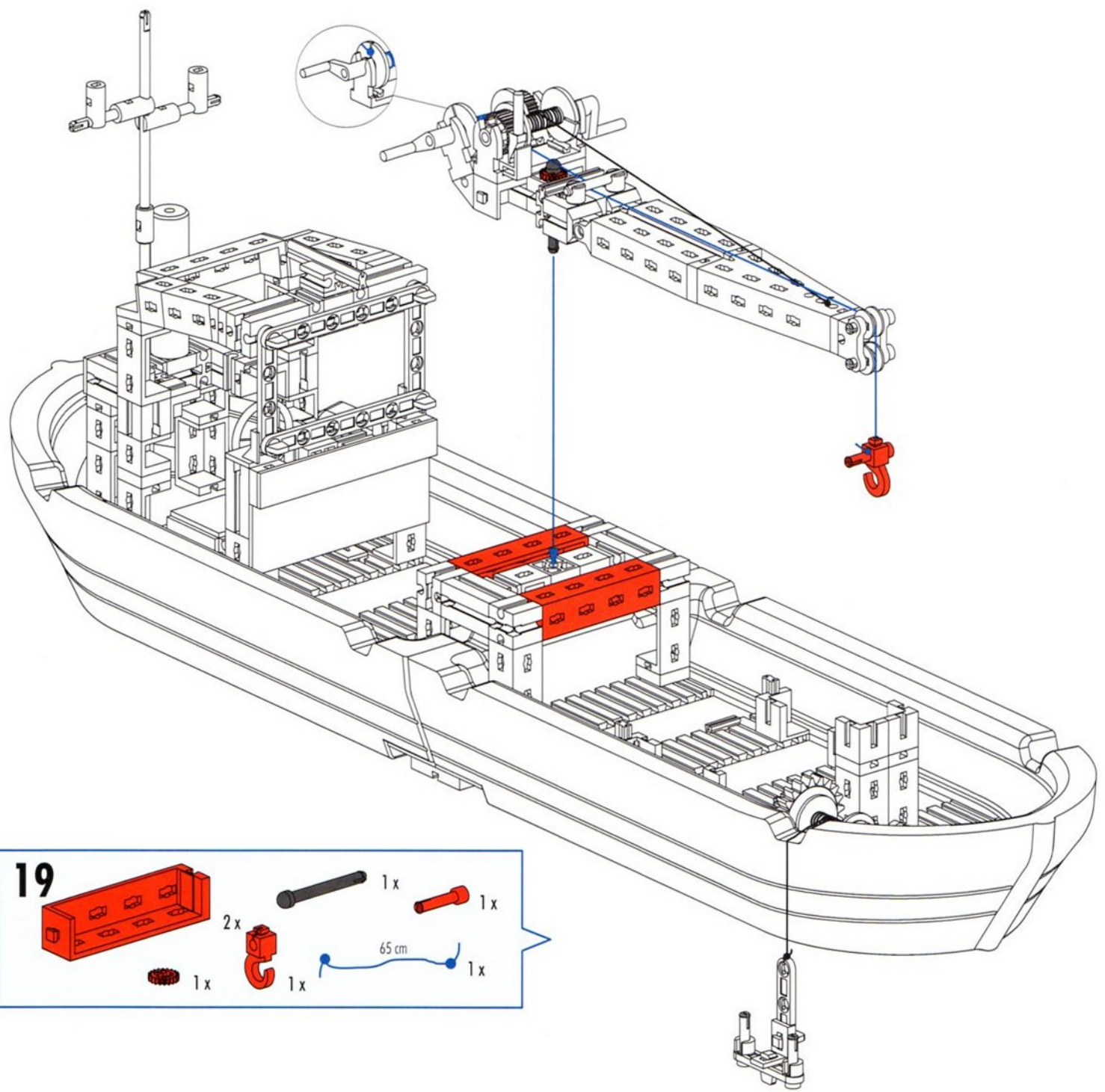
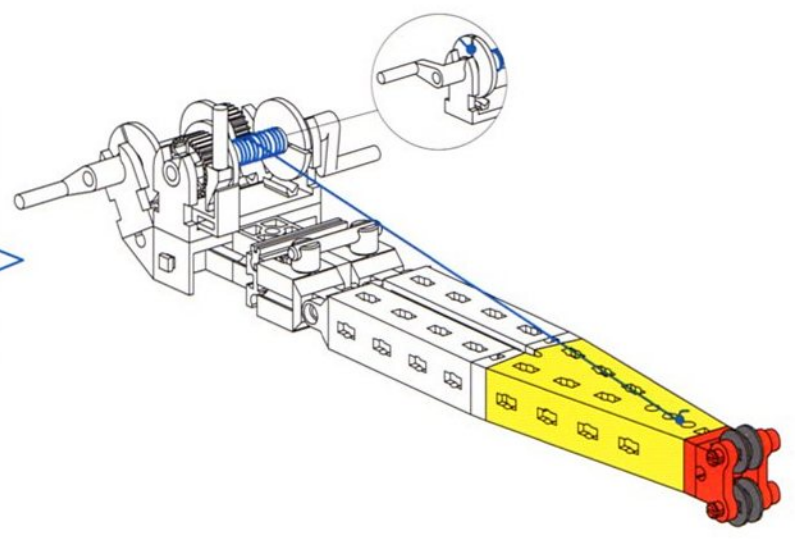

19

- 2 x Red Technic Beams (11 holes)
- 1 x Black Technic Pin
- 1 x Red Technic Pin
- 1 x Red Technic Connector
- 1 x Blue String (65 cm)

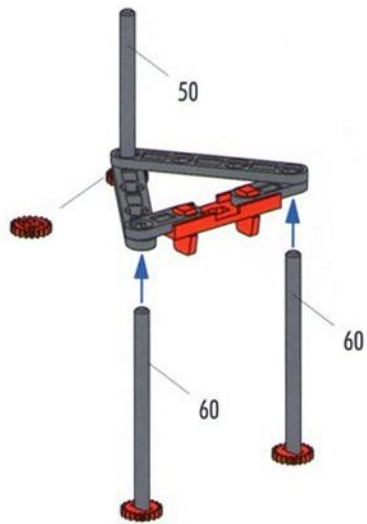

20

- 45 2x
- 15 2x
- 4 2x
- 3x
- 50 1x
- 60 2x
- 1x

60 mm
50 mm

21

- 5x
- 1x

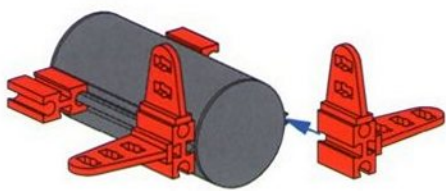
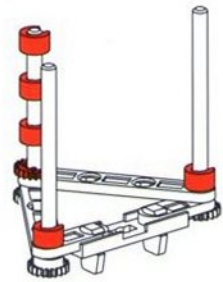

22

- 1x
- 2x
- 2x
- 4x

23

- 2x
- 15 2x
- 12x

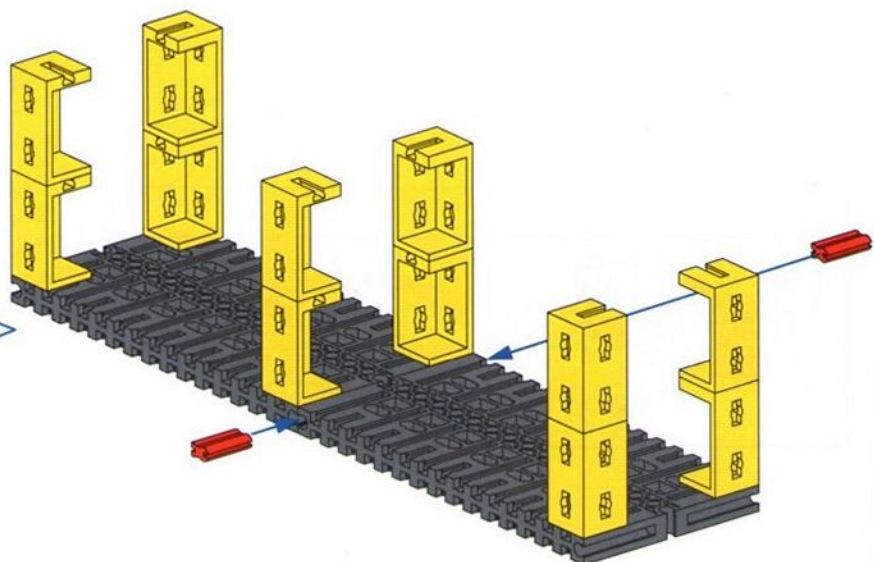

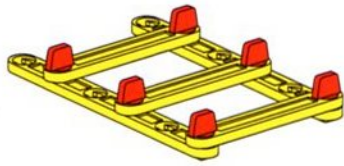

24

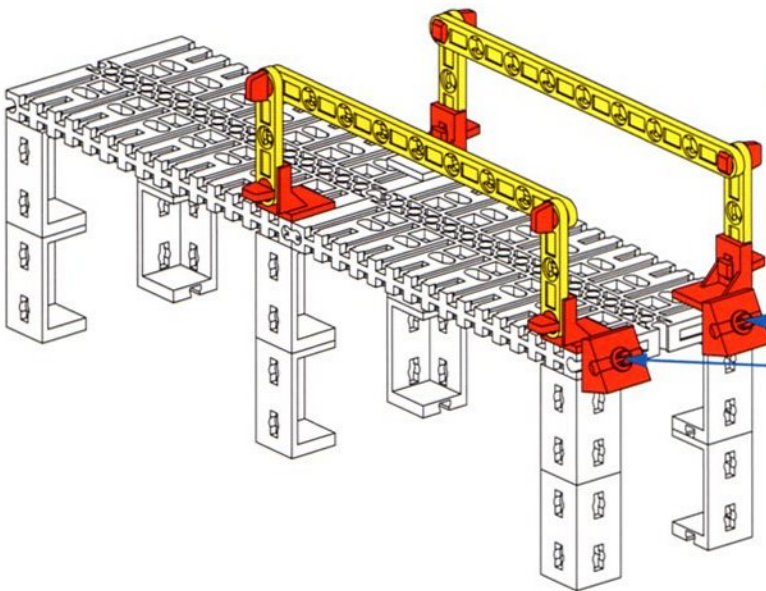
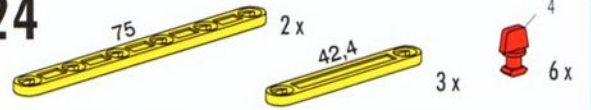

25

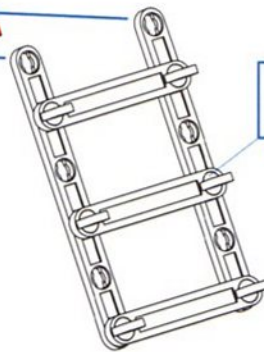
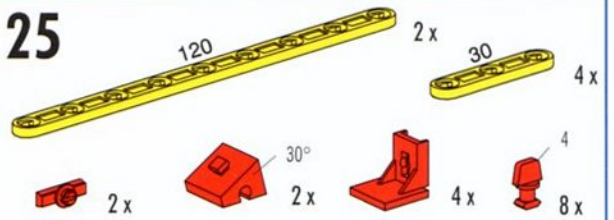

24

26



60 mm

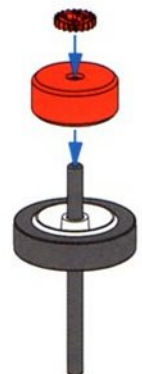

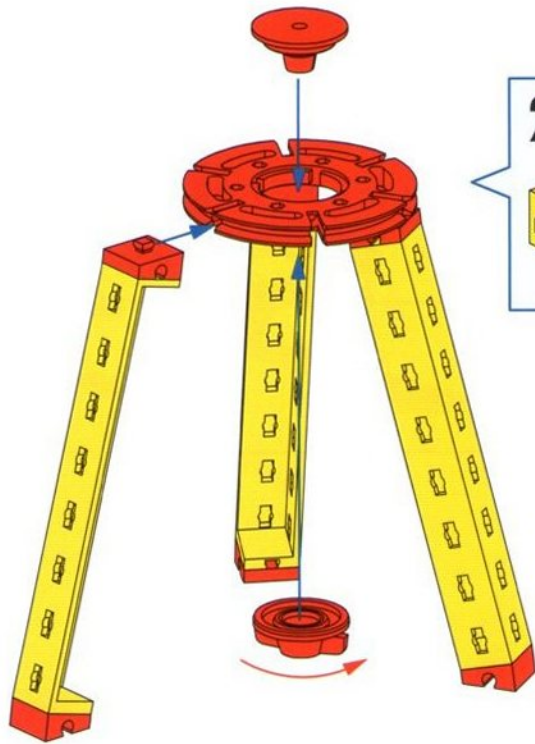

27

3x 1x 1x 1x

6x 15° 1x

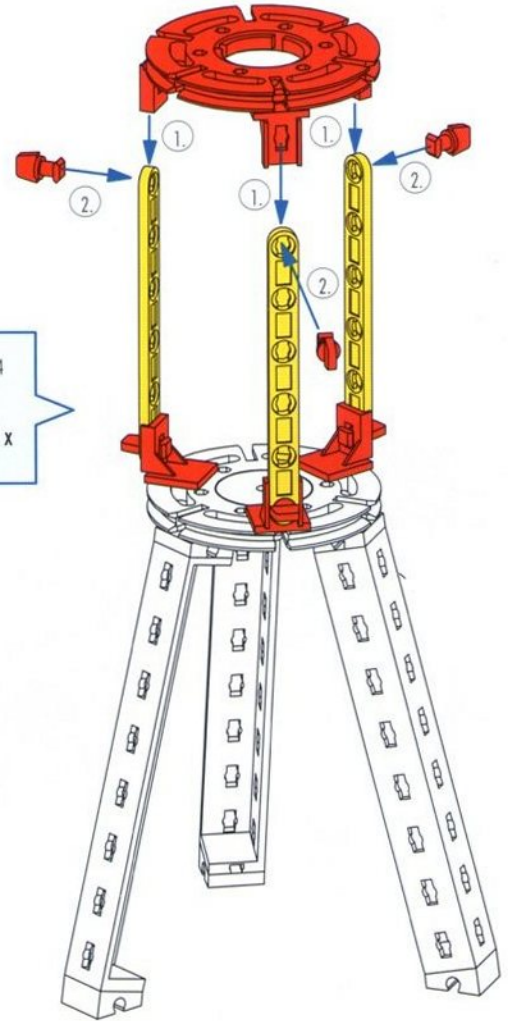

28

1x 3x 6x 4 6x

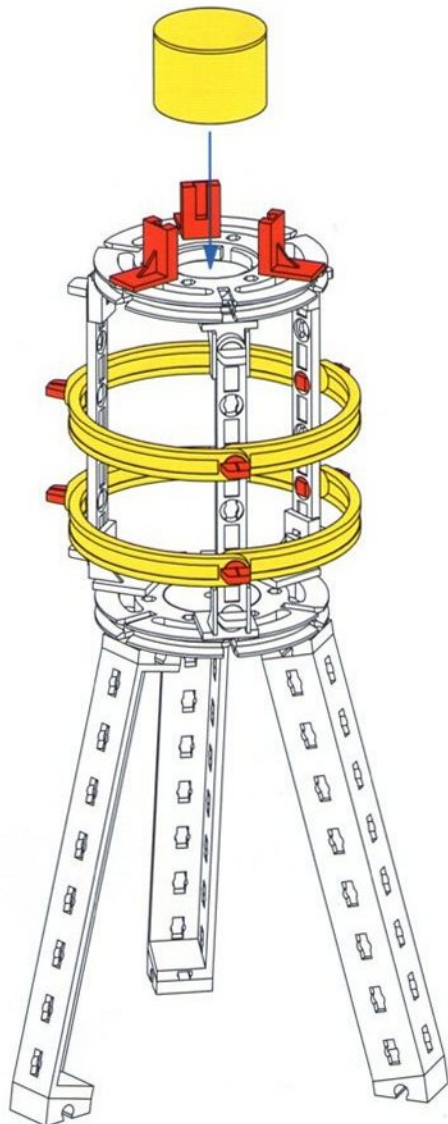

6 \neq 4

29

1x 1x 6x 6x 6x 3x

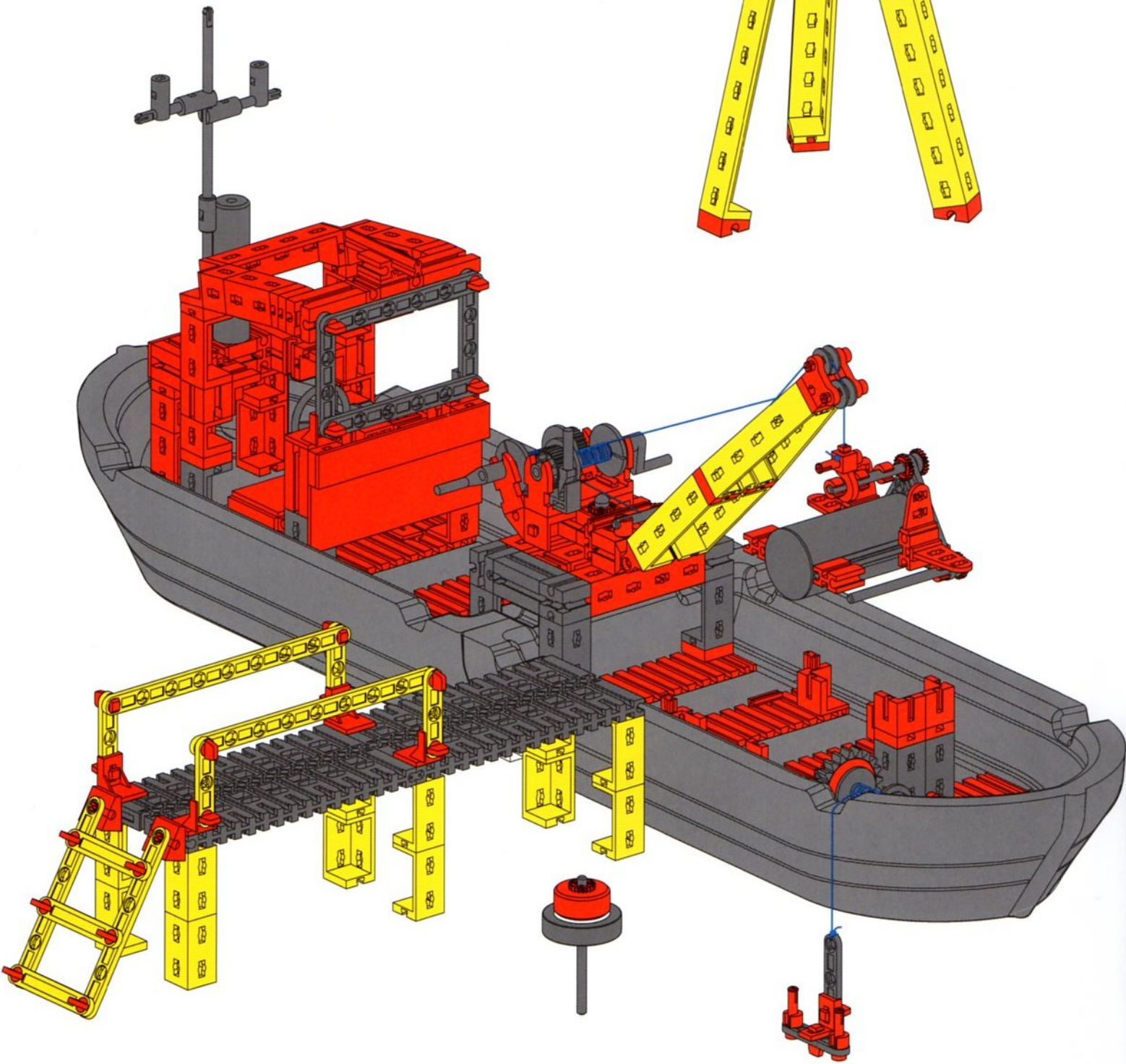
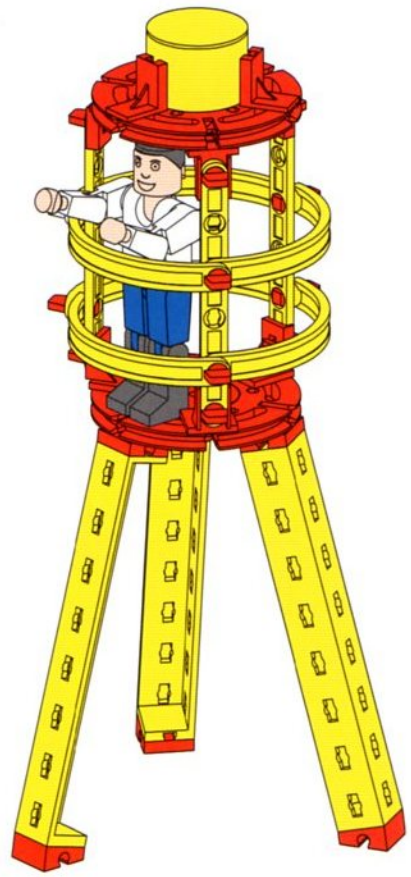

fischertechnik GmbH
Weinhalde 14-18
72178 Waldachtal
Germany
Phone +49 74 43/12-43 69
Fax +49 74 43/12-45 91
info@fischertechnik.de
www.fischertechnik.de

fischertechnik 

ADVANCED

