

Class Set Solar Energy

Bauanleitung
Assembly instruction
Instructions de montage
Bouwhandleiding
Instrucciones de construcción
Manual de montagem
Istruzioni di montaggio
Инструкция по сборке
安装说明书

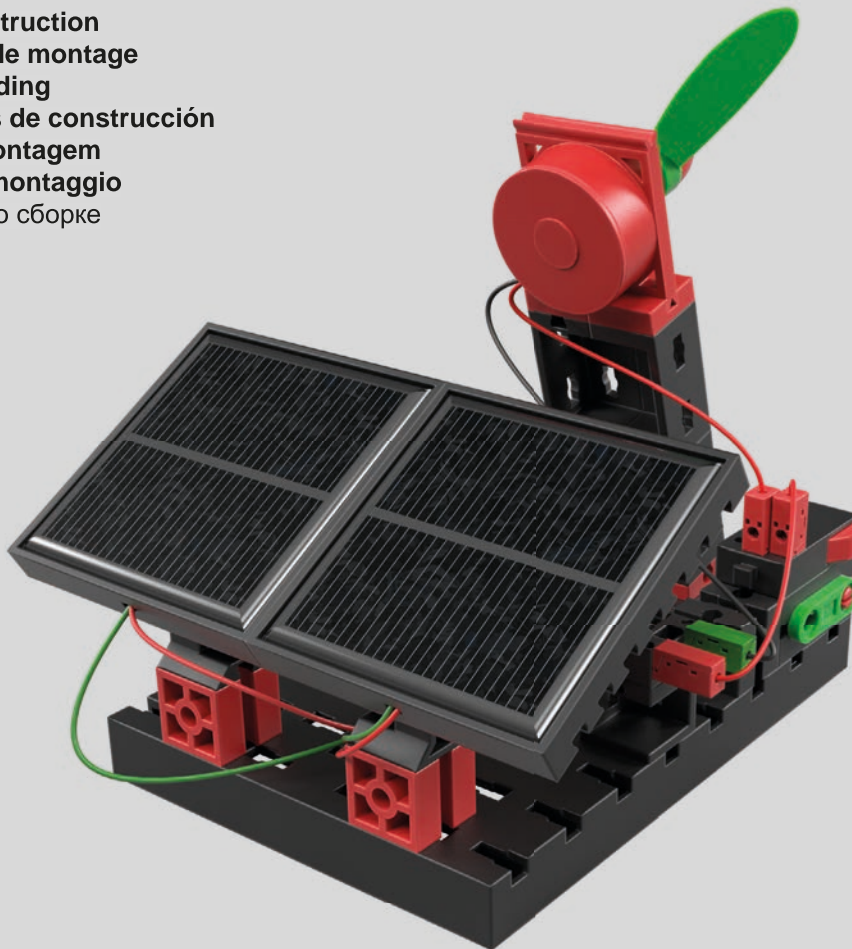

S T E M M A T H E M A T I K
I N F O R M A T I K
N A T U R W I S S E N S C H A F T
T E C H N I K

 SCIENCE  TECHNOLOGY  ENGINEERING  MATHEMATICS

3 Models

- Mit dem fischertechnik eLearning Portal geben wir dir die Möglichkeit, noch mehr Hintergrundwissen zum Thema des Baukastens zu erhalten. Über <https://www.fischertechnik.de/elearning-classeset-solarenergy> gelangen Sie direkt zum eLearning Portal.
- The fischertechnik eLearning Portal provides even more background knowledge on the topic of the building set. You can access the portal directly at <https://www.fischertechnik.de/elearning-classeset-solarenergy>
- Avec le portail e-learning fischertechnik, nous t'offrons la possibilité d'acquérir encore plus de connaissances de base au sujet du kit de construction. Tu peux accéder directement au portail via le lien <https://www.fischertechnik.de/elearning-classeset-solarenergy>
- Met het fischertechnik eLearning portaal geven wij jou de mogelijkheid, nog meer achtergrondkennis over het thema van de bouwdoos te verkrijgen. Via <https://www.fischertechnik.de/elearning-classeset-solarenergy> kom je rechtstreeks naar het portaal.
- Con el portal de eLearning de fischertechnik, te damos la posibilidad de obtener aún más conocimientos básicos sobre el tema del kit de montaje. Para acceder al portal, ingresa a <https://www.fischertechnik.de/elearning-classeset-solarenergy>
- Com o portal de eLearning da fischertechnik damos lhe a possibilidade de obter ainda mais conhecimentos aprofundados sobre os kits de construção. Em <https://www.fischertechnik.de/elearning-classeset-solarenergy> pode aceder diretamente ao portal de eLearning.
- Com o portal de aprendizagem virtual da fischertechnik, oferecemos a oportunidade de receber ainda mais informações contextuais sobre o tema kits de construção. Acesse o portal diretamente através do endereço <https://www.fischertechnik.de/elearning-classeset-solarenergy>
- На обучающем интернет-портале компании fischertechnik вы получите еще больше базовых знаний по теме конструирования. Ссылка <https://www.fischertechnik.de/elearning-classeset-solarenergy> ведет прямо на портал.
- 通过 fischertechnik 线上学习门户，我们让您能有机会了解更多有关该模块主题的背景知识。可通过 <https://www.fischertechnik.de/elearning-classeset-solarenergy> 直接前往该门户。



Inhalt
Contents
Contenu

Inhoud
Contenido
Conteúdo

Contenuto
Содержание
目录

Einzelteilübersicht / Spare parts list / Liste des pièces détachées / Onderdelenoverzicht / Lista da piezas / Resumo de peça individual /
 Singoli componenti / Перечень деталей / 零件概览 2

Montagetipps / Tips for assembly / Tuyaux pour le montage / Montagetips / Consejos para el montaje / "Dicas" para montagem /
 Consigli per il montaggio / Советы по сборке / 装配建议 3

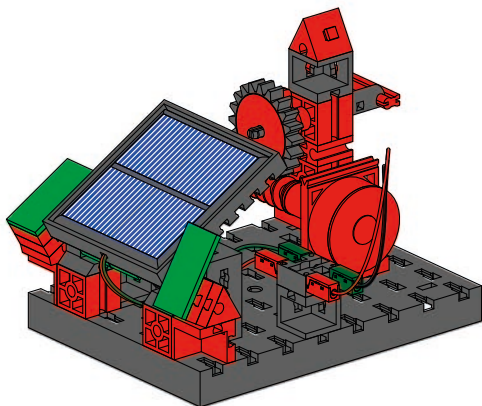

Funktionsmodell / Functional model / Modèle fonctionnel / Functioneel model /
 Modelo funcional / Modelo funcional / Lente d'ingrandimento /
 Функциональная модель / 功能模型 5

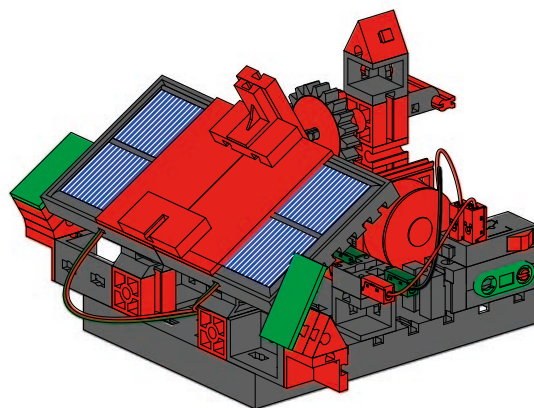

Funktionsmodell 2 / Functional model 2 / Modèle fonctionnel 2 / Functioneel model 2 /
 Modelo funcional 2 / Modelo funcional 2 / Lente d'ingrandimento 2 /
 Функциональная модель 2 / 功能模型2 9

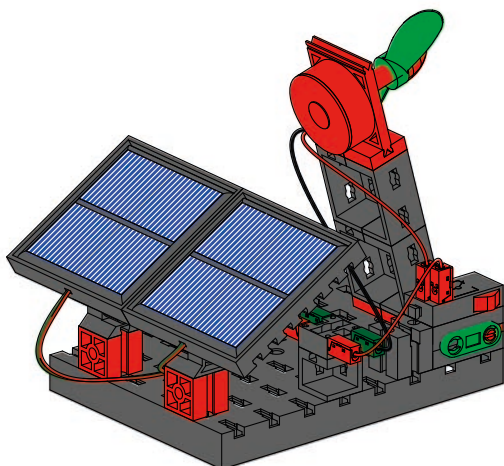









Ventilator / Ventilator / Ventilateur / Ventilator / Abanico / Ventilador /
 Ventilatore / Вентилятор / 扇子 14

Einzelteilübersicht

Spare parts list















Liste des pièces détachées

	31 010 2 x
	31 011 1 x
	31 021 1 x
	31 058 1 x
	31 330 1 x
	31 848 1 x
	31 915 1 x
	31 981 2 x
	32 064 4 x
	32 879 1 x
	32 881 1 x
	35 031 1 x
	35 049 1 x
	35 064 1 x

Onderdelenoverzicht

Lista da piezas









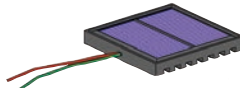

Resumo de peça individual

	35 608 1 x
	35 969 1 x
	36 227 1 x
	36 920 4 x
	36 922 3 x
	37 237 6 x
	37 238 2 x
	37 468 1 x
	37 679 1 x
	37 681 1 x
	37 783 1 x
	37 858 1 x
	38 216 2 x
	38 240 2 x

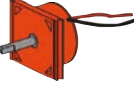
Singoli componenti

Перечень деталей

零件概览

	38 249 2 x
	38 423 1 x
	38 428 3 x
	146 142 2 x
	146 529 1 x
	156 108 1 x
	156 494 1 x
	156 504 4 x
	172 804 2 x
	172 805 2 x
	181 583 3 x
	181 584 5 x
	182 622 1 x

Montagetipps
Tips for assembly
Tuyaux pour le montage

Montagetipps
Consejos para el montaje
"Dicas" para montagem

Consigli per il montaggio
Советы по сборке
装配建议

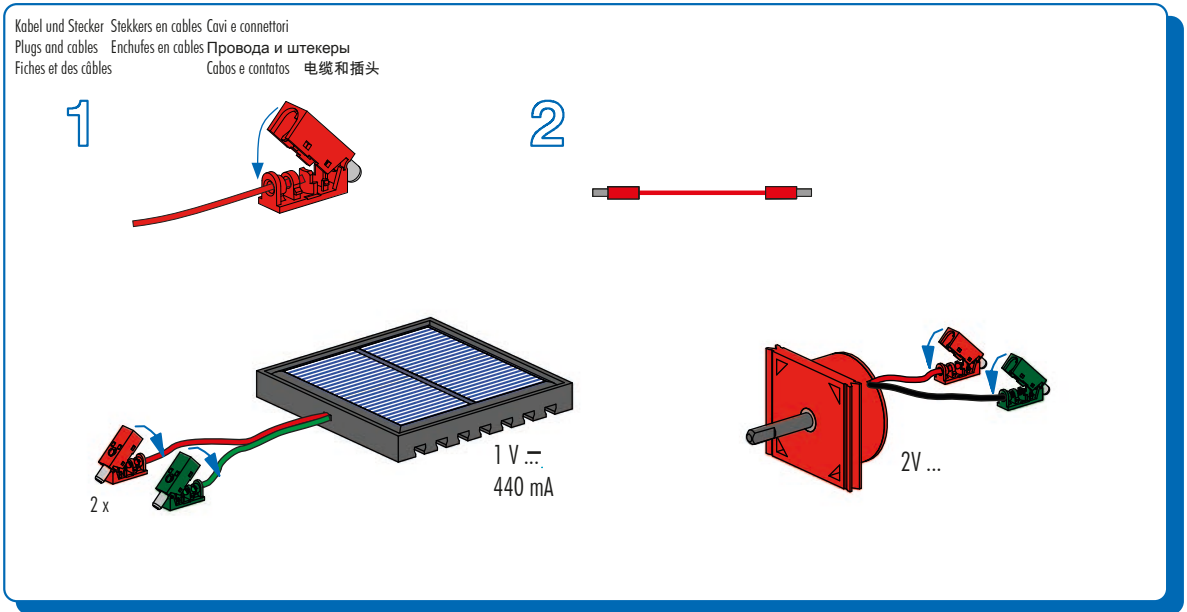
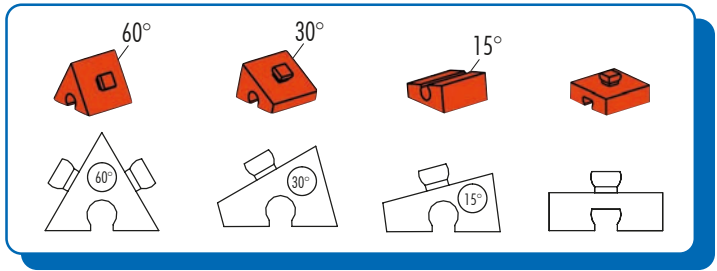
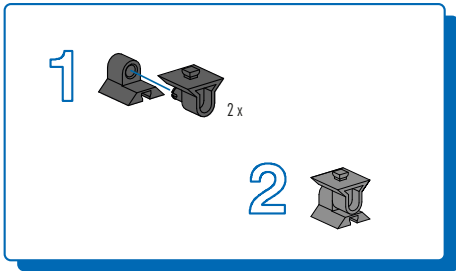

Sicherheitshinweise
Safety Information
Consignes de sécurité

Veiligheidsrichtlijnen
Indicaciones de seguridad
Observações sobre segurança

Informazioni per la sicurezza
 Указания по технике безопасности
 安全指南

- Die Solarzellen funktionieren bei Sonnenlicht oder mit einer Halogenlampe. Energiesparlampen oder Leuchtstoffröhren sind nicht geeignet.
- The solar cells work with sunlight or with a halogen light. CFL bulbs or fluorescent lights are not suitable.
- Les cellules solaires fonctionnent si elles sont exposées aux rayons du soleil ou à la lumière d'une lampe halogène. Les lampes à faible consommation d'énergie ou les tubes fluorescents ne sont pas appropriés.
- De zonnecellen werken op zonlicht of met behulp van een halogeenlamp. Spaarlampen of TL-lampen zijn niet geschikt.
- Las celdas solares funcionan con luz solar o una lámpara halógena. Lámparas de ahorro de energía o tubos fluorescentes no son apropiados.
- As células solares funcionam com luz solar ou uma lâmpada de halogênio. Lâmpadas economizadoras de energia ou lâmpadas fluorescentes não são adequadas.

- Le celle solari funzionano con la luce del sole o con una lampada alogena. Le lampade a risparmio energetico e i tubi fluorescenti non sono adatti.
- Солнечные элементы работают от солнечного света или галогенной лампы. Энергосберегающие и люминесцентные лампы не подходят.
- С太阳能电池在太阳光下或用卤素灯工作。不适合使用节能灯或荧光灯管。

- Achtung! Verletzungsgefahr an Bauteilen mit funktionsbedingten scharfen Kanten und Spitzen!
- Caution! Be careful not to hurt yourself on components with sharp or pointed edges!
- Attention! Risque de blessure sur les éléments comportant des arêtes et o pointes vives indispensables au bon fonctionnement!
- Let op! U kunt zich bezeren aan bouwstenen met sherpe randen of punten!
- Atención! ¡cuidado, no te hagas daño con los componentes con bordes afilados o puntiagudos!

- Atenção! Perigo de ferimentos em peças componentes com cantos vivos e pontas obrigatórios para o funcionamento !
- Attenzione! Pericolo di lesioni dovute a componenti con spigoli vivi e punte per motivi funzionali!
- Будьте осторожны! Об острые края деталей и и наконечники можно порезаться!
- 注意！因功能需要而带有锋利的棱边和尖角的部件可能会带来受伤危险！



- Alle Einzelteile, insbesondere bewegliche Teile sind falls notwendig zu warten und zu reinigen.
- All components, especially moving parts, should be maintained and cleaned as necessary.
- Toutes les pièces détachées et en particulier les pièces mobiles, sont, si nécessaire, à entretenir et à nettoyer.
- Alle onderdelen, vooral de bewegende delen, kunnen, indien noodzakelijk, onderhouden en gereinigd worden.

- Es necesario mantener limpio y en buen estado cada una de las piezas. Particularmente las piezas móviles.
- Todas as peças individuais, especialmente peças móveis, devem ser submetidas à manutenção e limpas se necessário.
- Se necessario, tutti i singoli componenti, soprattutto le parti mobili, si devono eventualmente sottoporre a manutenzione e pulizia.
- Все детали, особенно подвижные, требуют ухода и чистки.
- 必要时应保养和清洁所有零件，尤指运动部件。

Hinweise zum Umweltschutz / Instructions for Environmental Protection / Remarques de protection de l'environnement / Bescherming van het milieu / Notas con respecto a la protección del medio ambiente / Instruções para a proteção do meio ambiente / Indicazioni sulla tutela ambientale / Указания по охране окружающей среды / 有关环保的提示 :

www.fischertechnik.de/environment

4

1 x  1 x  1 x 

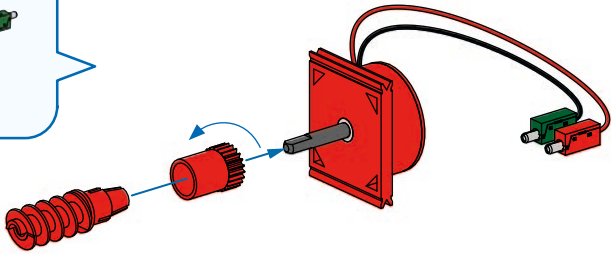



5

 2 x

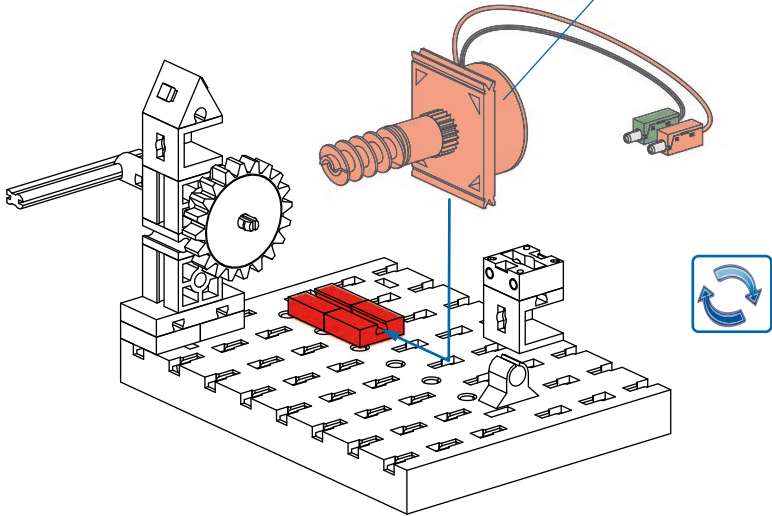
4



6

 2 x  2 x

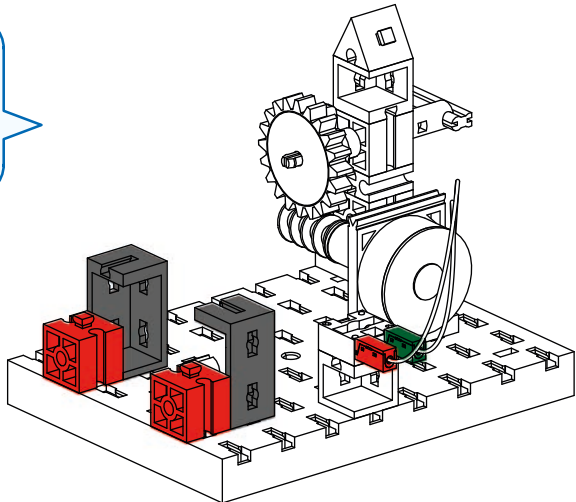

7



2x



1x

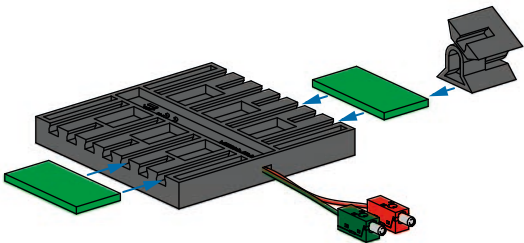
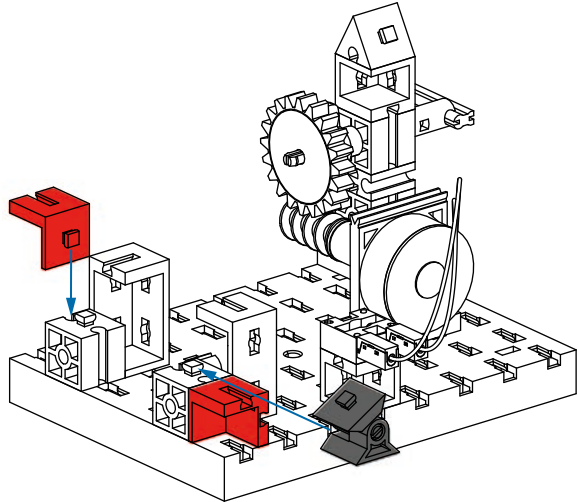

8



2x



1x

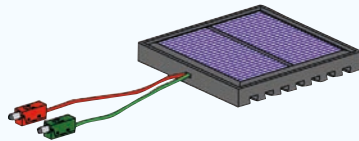



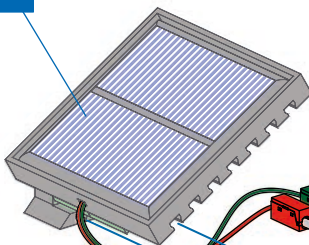

1x

8

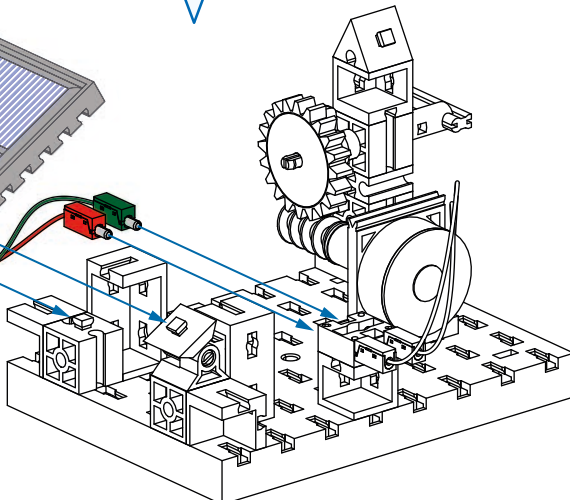

9



10  1x  1x  4x  2x

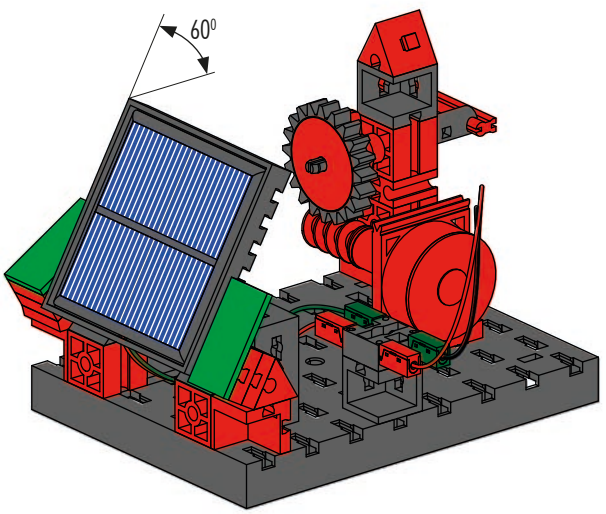
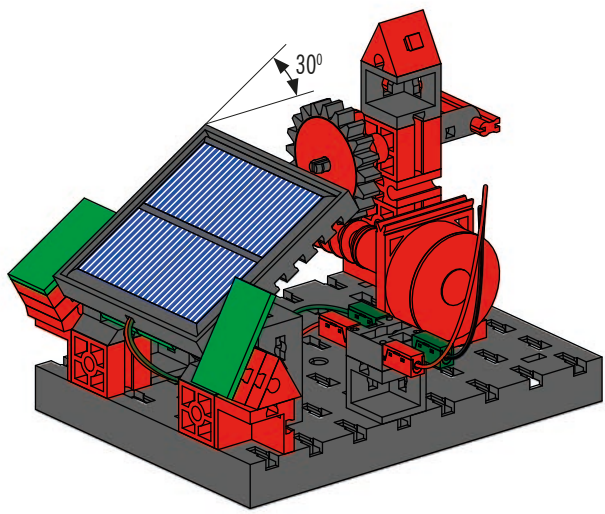
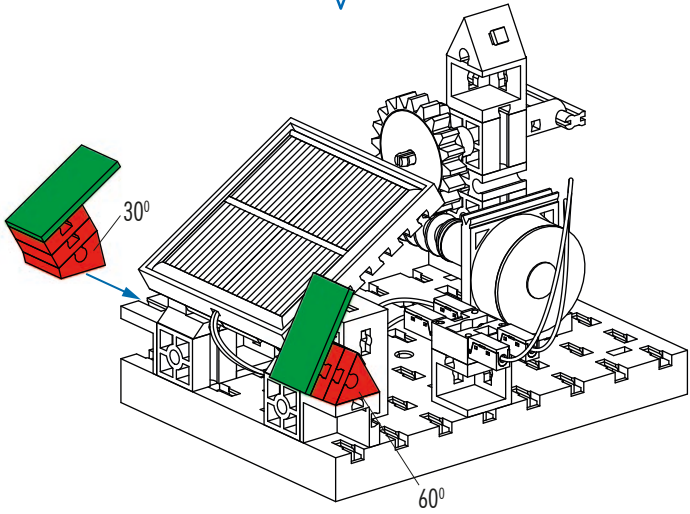
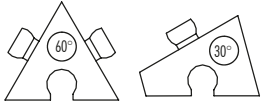

Schaltplan
Circuit diagram
Plan électrique

Schakelschema
Diagrama de circuitos
Plano elétrico de ligação

Schema elettrico
Схема подключения
电路图

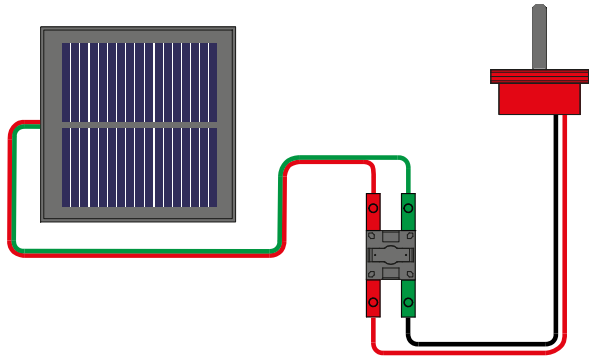

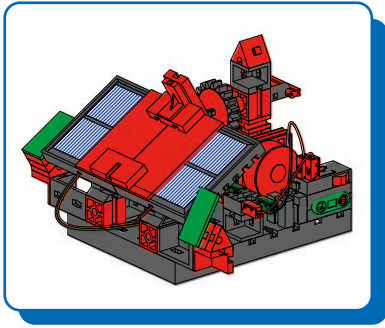

Funktionsmodell 2
 Functional model 2
 Modèle fonctionnel 2

Functioneel model 2
 Modelo funcional 2
 Modelo funcional 2

Lente d'ingrandimento 2
 Функциональная
 модель 2
 功能模型2

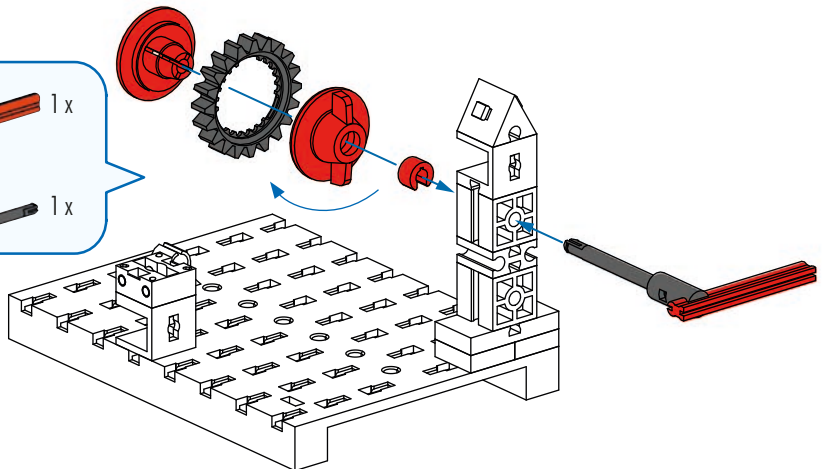
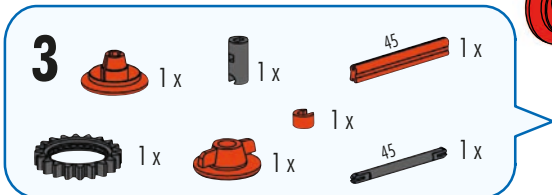
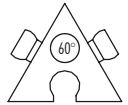
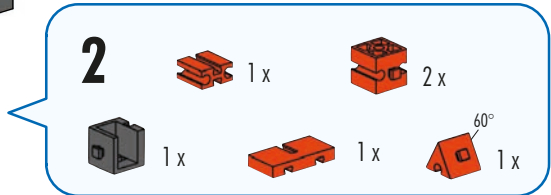
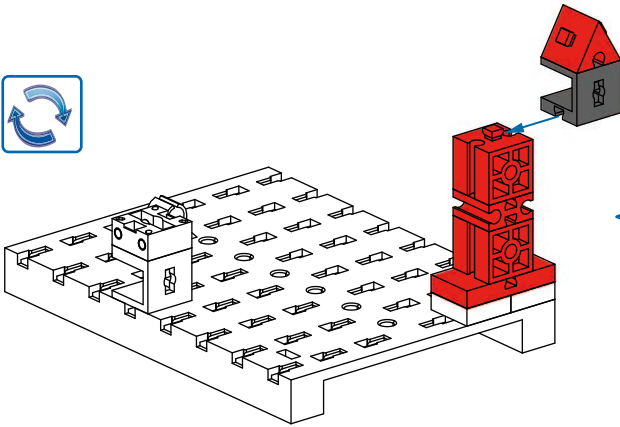
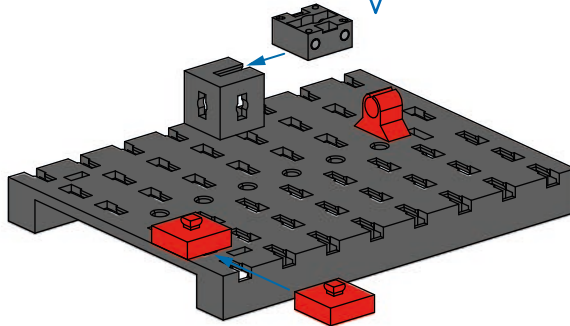
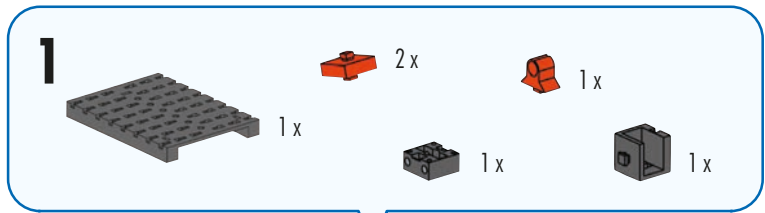

- 4**
- 1x [Grey Motor]
 - 1x [Grey Technic Brick]
 - 1x [Green Technic Pin]
 - 1x [Grey Technic Beam]
 - 1x [Grey Technic Connector]
 - 1x [Red Technic Pin]

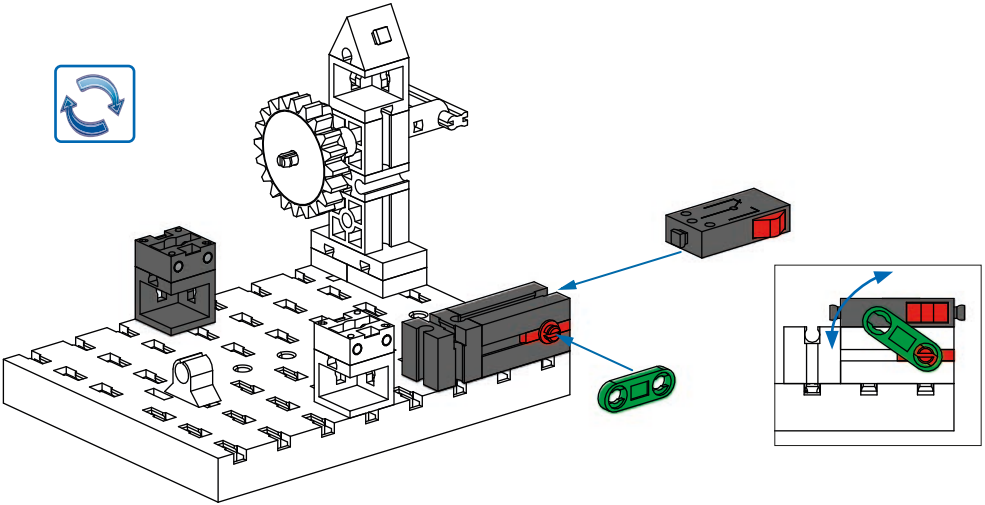

- 5**
- 1x [Red Gear]
 - 1x [Red Gear with Axle]
 - 1x [Red Technic Pin]

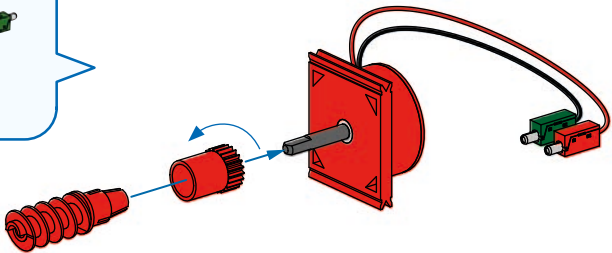

- 6**
- 2x [Red Technic Pin]

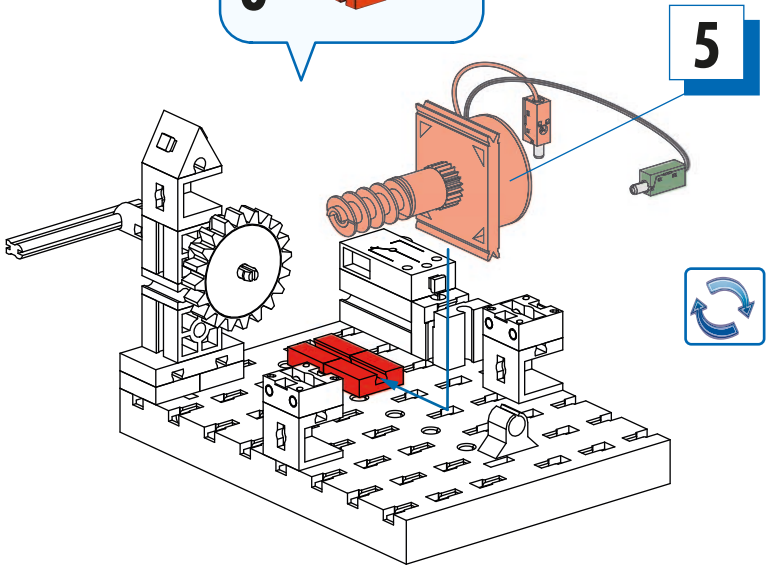

7



4 x



2 x

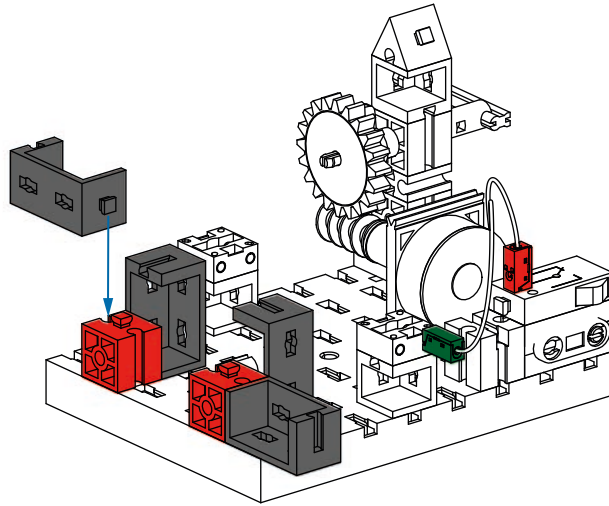

8

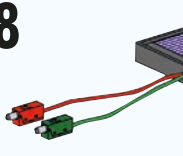

1 x



1 x



2 x

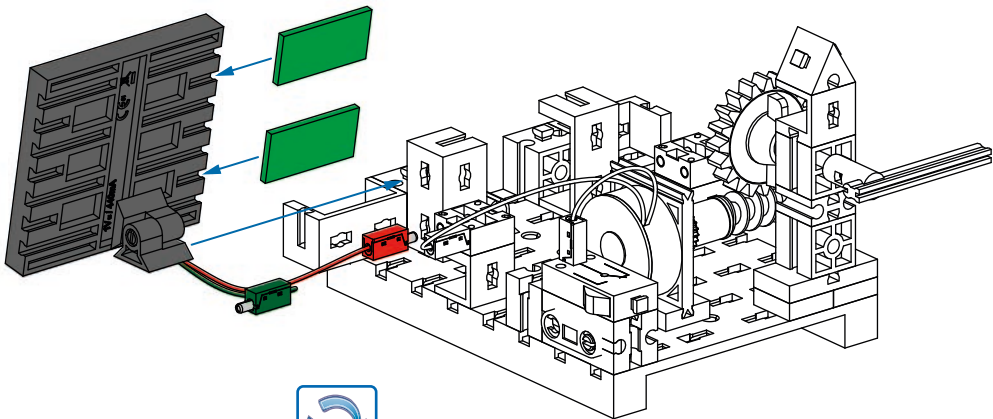

9

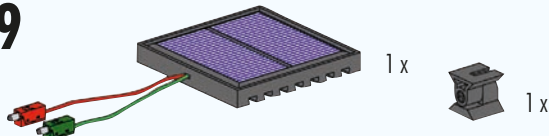

1x 1x

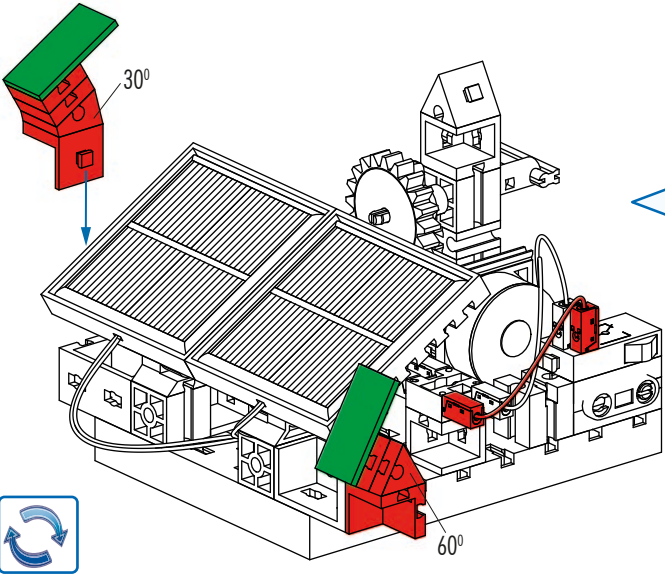
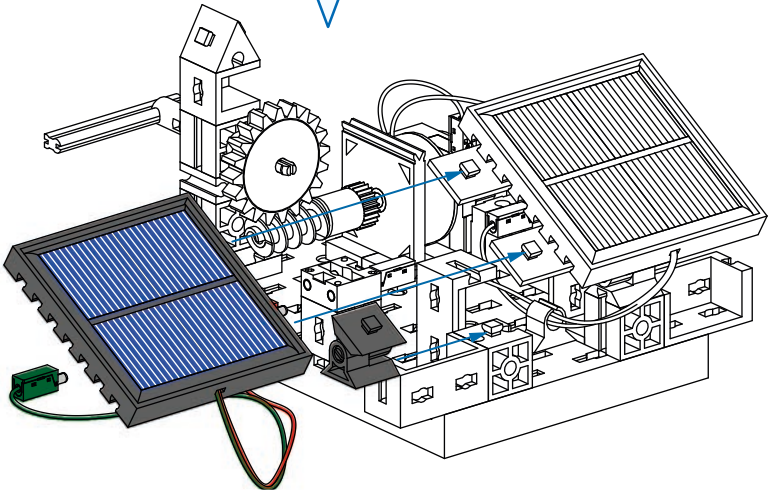

10

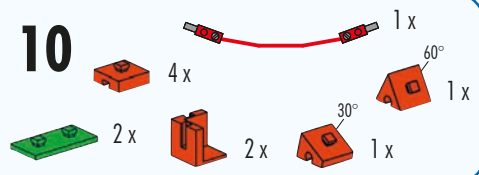

4x 1x 1x 1x 1x 1x 1x

2x 2x 2x 1x 1x

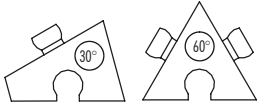

11

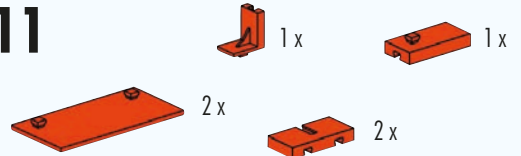

2x 1x 1x 2x

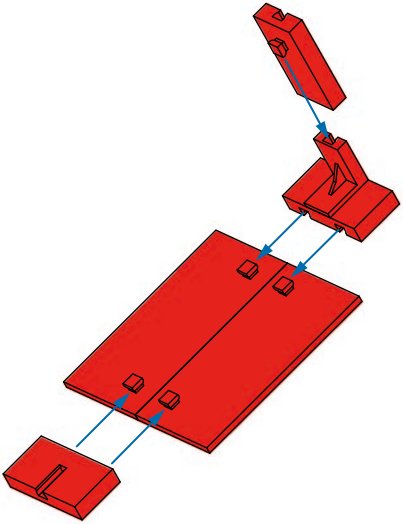

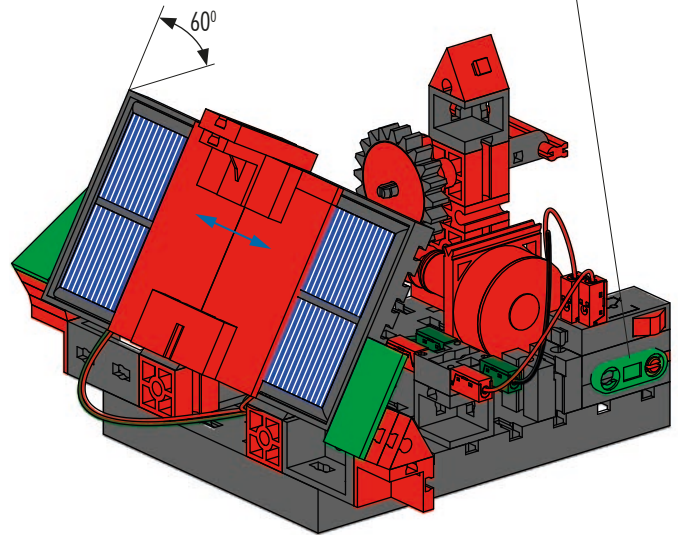
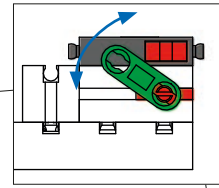
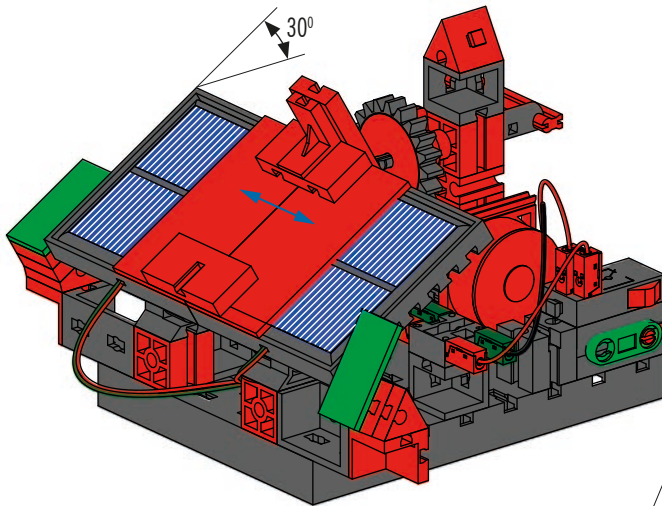

Schaltplan
Circuit diagram
Plan électrique

Schakelschema
Diagrama de circuitos
Plano elétrico de ligação

Schema elettrico
Схема подключения
电路图

Aufgabe 1
Task 1
Exercice 1

Taak 1
Tarea 1
Tarefa 1

Compito 1
Задание 1
任务 1

Aufgabe 2
Task 2
Exercice 2

Taak 2
Tarea 2
Tarefa 2

Compito 2
Задание 2
任务 2

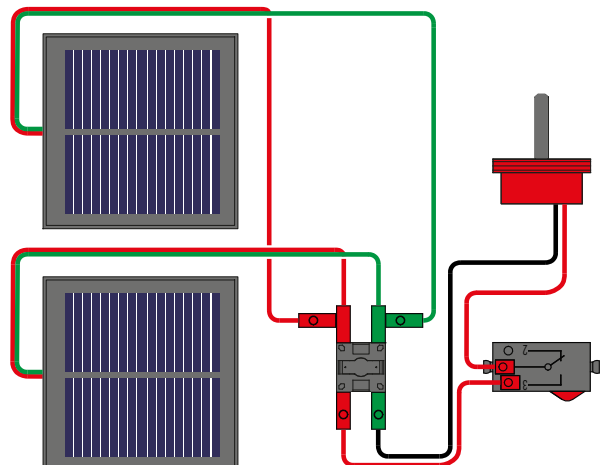
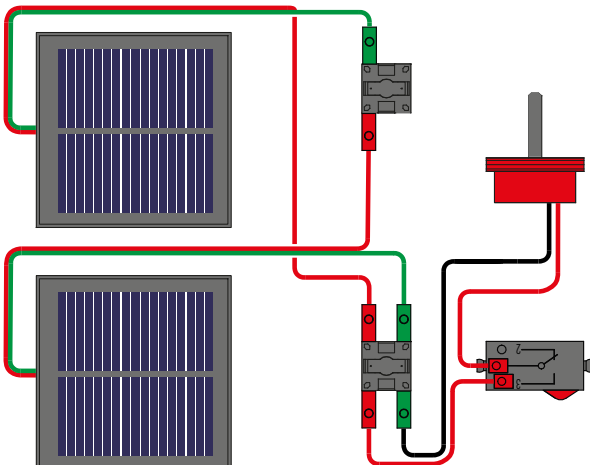

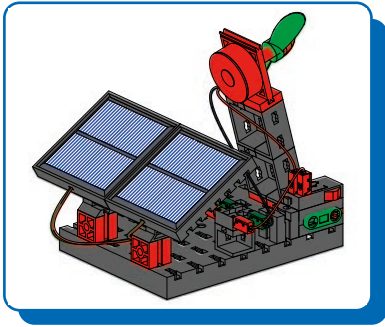

Ventilator
Ventilator
Ventilateur

Ventilator
Abanico
Ventilador

Ventilatore
Вентилятор
扇子

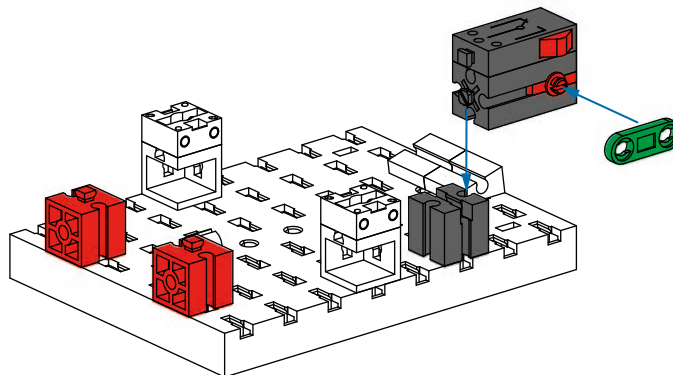
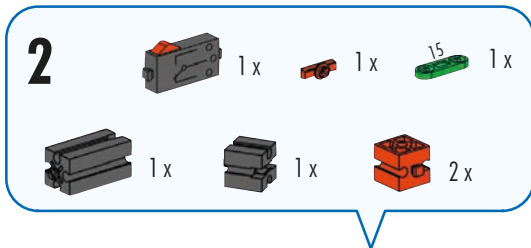
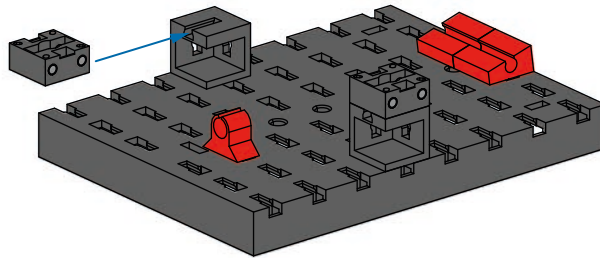
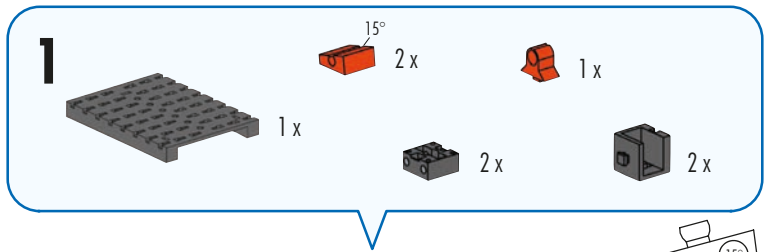

3

- 4 x [Grey Technic Brick with Hole]
- 1 x [Green Propeller]
- 1 x [Red Pin]
- 2 x [Orange Technic Pin]
- 1 x [Red Motor]

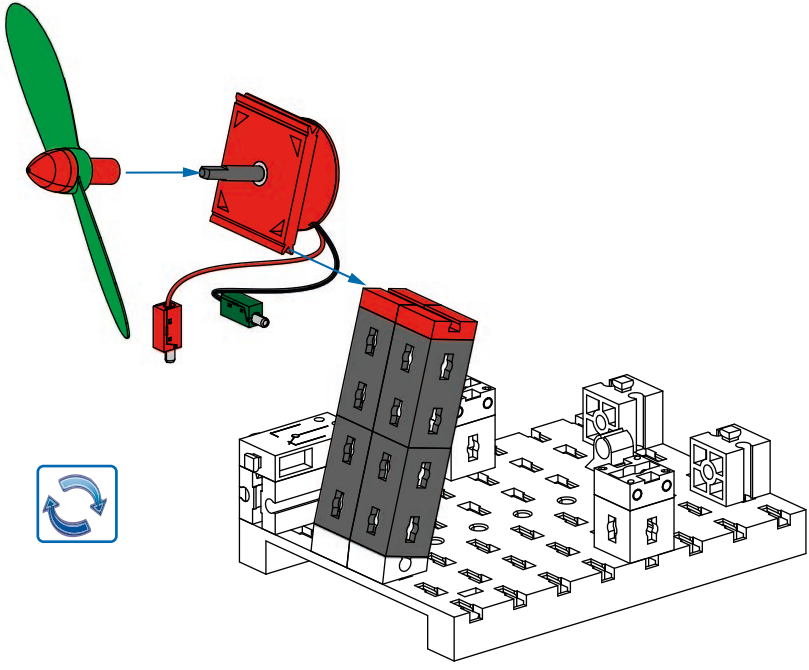

4

- 1 x [Purple PCB]
- 1 x [Grey Technic Brick]
- 2 x [Green PCB]

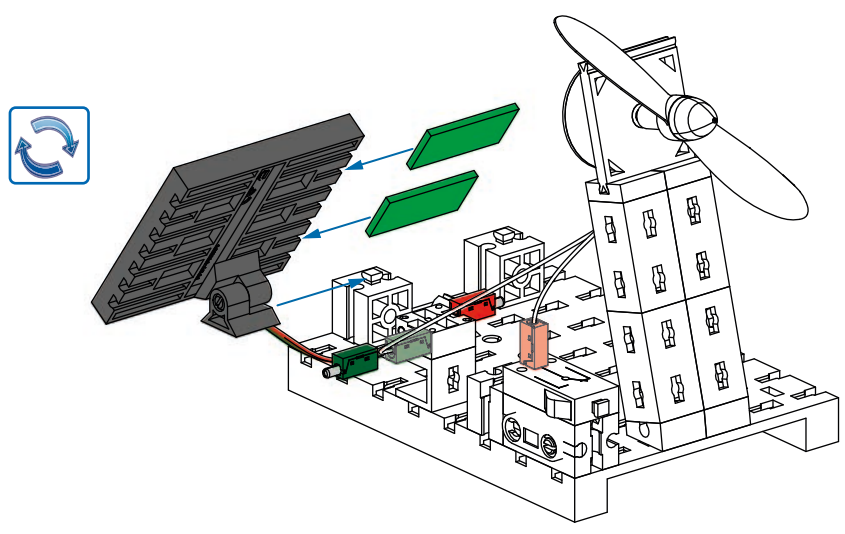

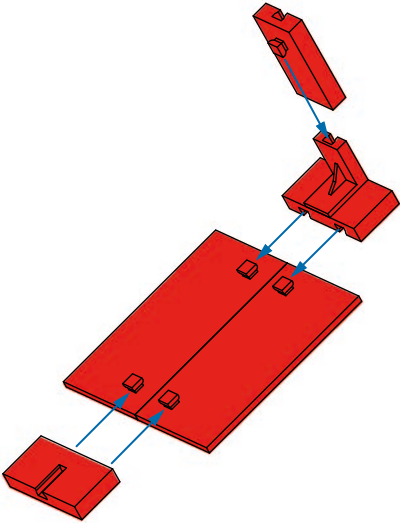
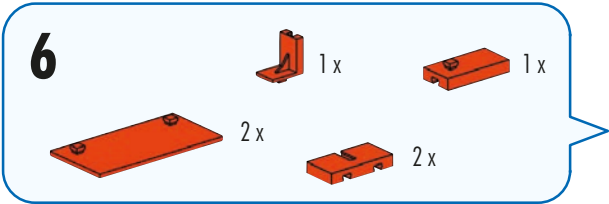
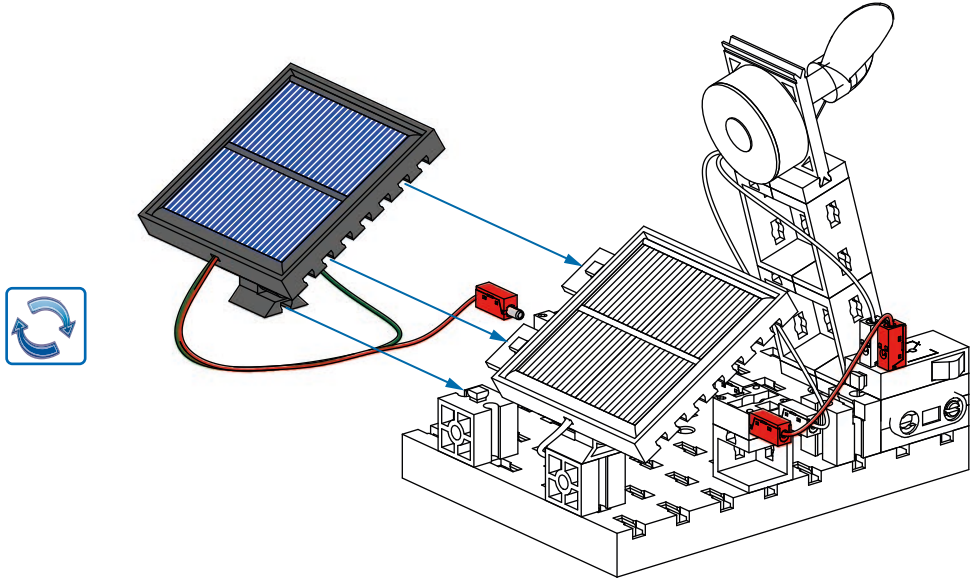
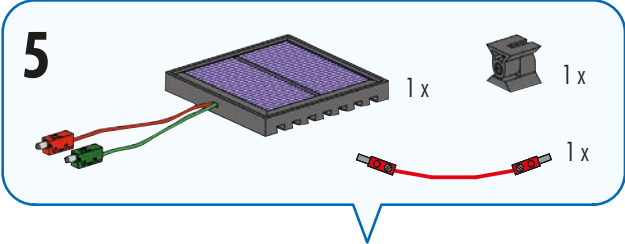

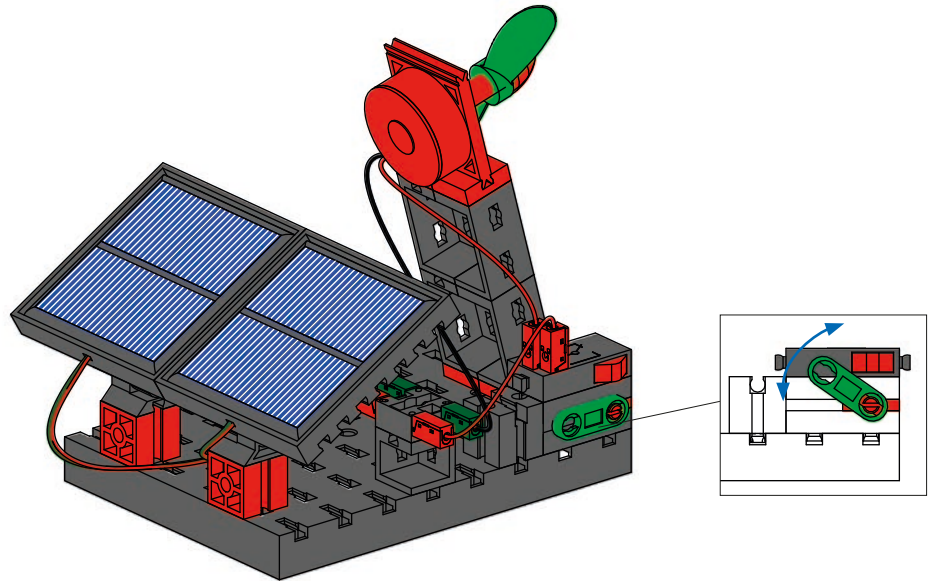

Schaltplan
 Circuit diagram
 Plan électrique

Schakelschema
 Diagrama de circuitos
 Plano elétrico de ligação

Schema elettrico
 Схема подключения
 电路图

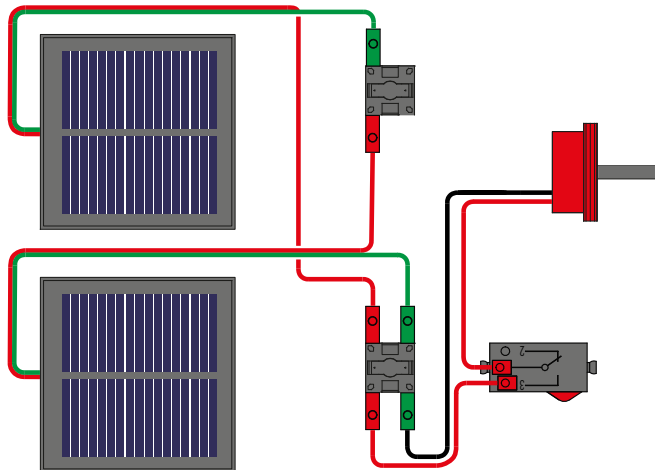

Class Set Solar Energy

fischertechnik GmbH
Klaus-Fischer-Str. 1
72178 Waldachtal
Germany
Phone: +49 74 43/12-43 69
Fax: +49 74 43/12-45 91
info@fischertechnik.de
www.fischertechnik.de

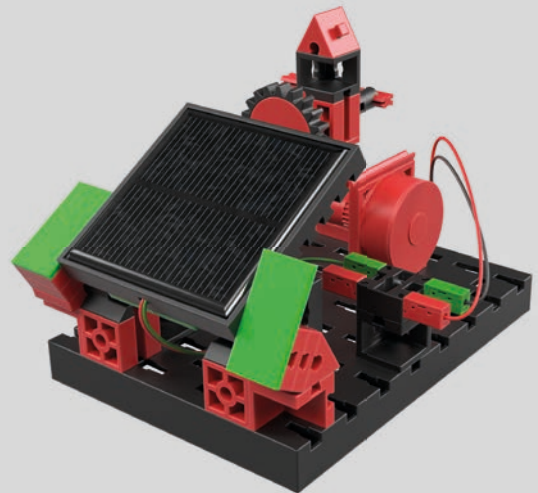
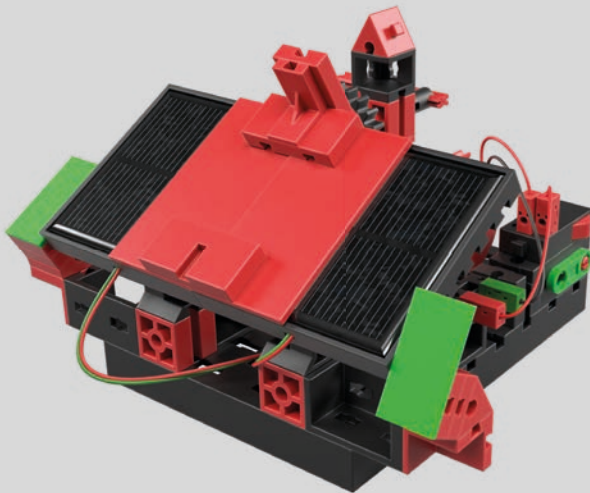

183289 - 12/22 - Co - Printed in Germany - Technische Änderungen vorbehalten - Subject to technical modifications

S T E M M A T H E M A T I K
I N F O R M A T I K
N A T U R W I S S E N S C H A F T
T E C H N I K

 SCIENCE  TECHNOLOGY  ENGINEERING  MATHEMATICS

3 Models