

Teleskop-Mobilkran  
Heavy duty crane truck  
Grue télescopique mobile  
Teleskoopkraanwagen  
Camión grúa telescópica  
Gru telescopica semovente  
Teleskop-Mobilkran





**Teleskop-Mobilkran**

Baustufen für den Zusammenbau des Grundmodells Seite 4-32.

**Telescopic mobile crane**

Series of constructional steps for the assembly of the basic model page 4-32.

**Grue mobile télescopique**

Etapas du montage pour l'assemblage du modèle de base. Pages 4-32

**Mobiele kraan in telescoop-uitvoering**

Konstruktiedelen voor de montage van het grondmodel op blz. 4-32.

**Telescopio-grúa móvil**

Etapas de montaje para el modelo básico. Páginas 4-32

**Gru telescopica-mobile**

Stadi di costruzione per il montaggio del modello base. Pagina 4-32

**Teleskop-svängkransvagn**

Monteringssteg för grundmodellens hopmontering sidorna 4-32.

**Fernlenk-Set/Radantrieb und Servo**

Baustufen für den Einbau der Motorisierung Seite 33-39.

**Remote control set/wheel drive and servo facility**

Series of constructional steps for the installation of the motorization equipment page 33-39.

**Appareil de pilotage à distance/pont et servo**

Etapas du montage pour l'assemblage de la motorisation. Pages 33-39

**Set voor afstandbediening van wiel aandrijving en servomechanisme**

Konstruktiedelen voor de montage van de motorisering op blz. 33-39.

**Estuche de control remoto/rueda propulsora y servo**

Etapas de construcción para el montaje de la motorización. Páginas 33-39.

**Impianto di telecomando/motore alle ruote e servo**

Stadi di costruzione per il montaggio. Pagina 33-39

**Fjärrstyrningsset/hjuldrivning och servo**

Monteringssteg för inmontering av motoriseringen sidorna 33-39.





#### Funkfernsteuerungs-Set

Einbau der Fernsteuerung in das motorisierte Modell Seite 40–47.

#### Radio control set

Installation of the remote control in the motorized model Page 40–47.

#### Poste radio de télécommandes

Montage de la télécommande sur le modèle motorisé. Pages 40–47.

#### Set voor draadloze besturing

Montage van de afstandbediening in het gemotoriseerde model op blz. 40–47.

#### Estuche de radiotelemando

Montaje del control remoto en el modelo motorizado. Páginas 40–47.

#### Impianto di radiotelecomando

Montaggio del telecomando nel modello a motore. Pagina 40–47.

#### Radiofjärrstyrningsset

Fjärrstyrningens inmontering i den motoriserade modellen sidorna 40–47.



#### Empfänger 2

Fernsteuern der Kranfunktionen Seite 48–52.

#### Receiver 2

Remote control of the crane functions. Page 48–52.

#### Récepteur 2

Télécommande des fonctions de la grue. Pages 48–52.

#### Ontvanger 2

Afstandbediening van de kraanfuncties op blz. 48–52.

#### Receptor 2

Dirección a distancia de las funciones de la grúa. Páginas 48–52.

#### Ricevente 2

Telecomando delle funzioni della gru. Pagina 48–52.

#### Mottagare 2

Fjärrstyrning av kranfunktionerna sidorna 48–52.



1

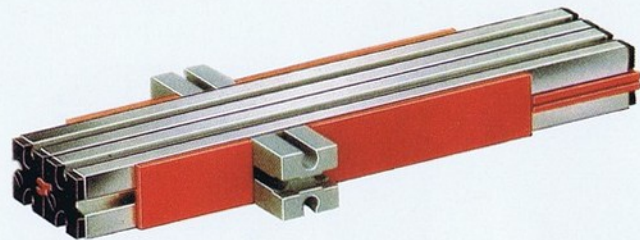
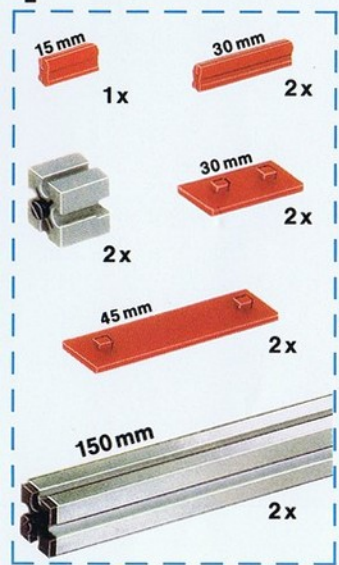

3

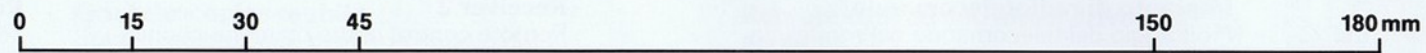
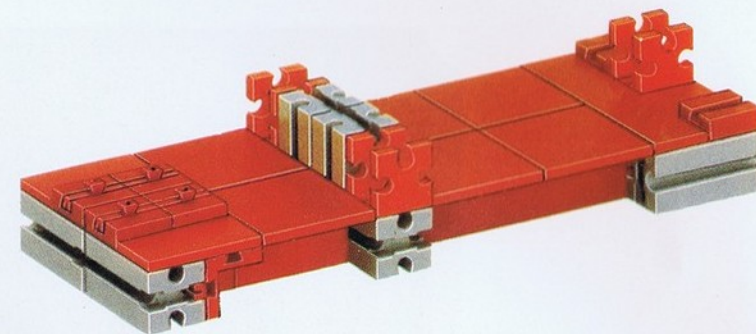
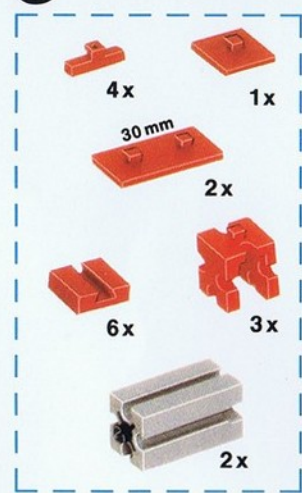

2

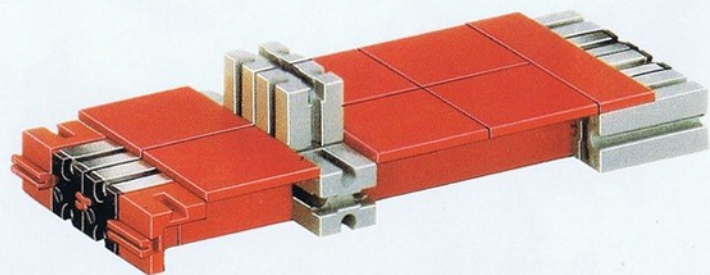
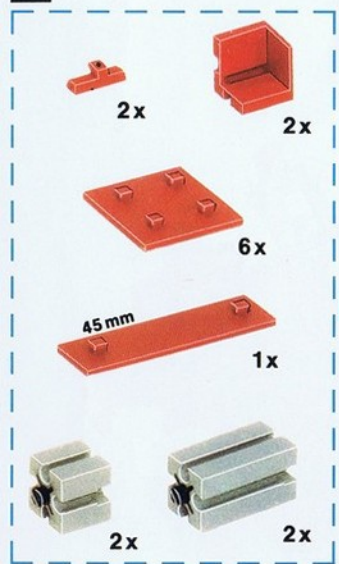

4

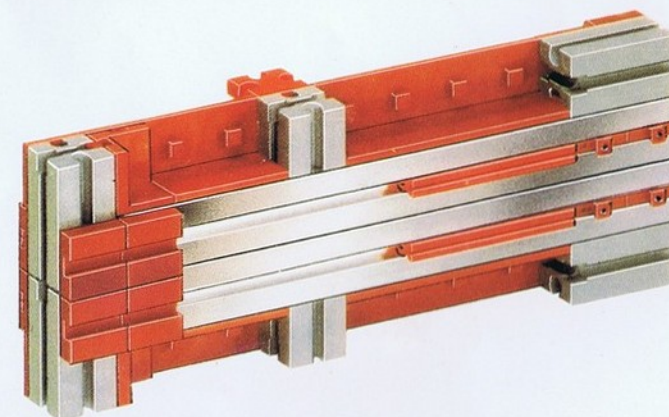
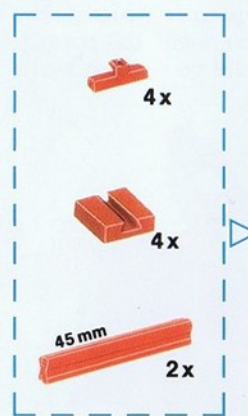

5

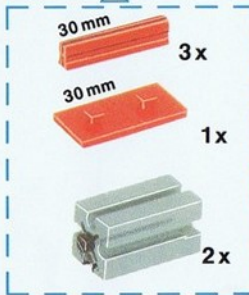
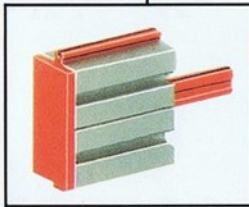
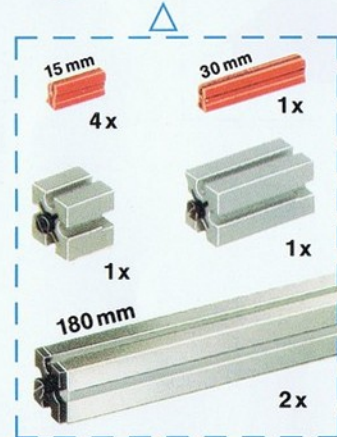
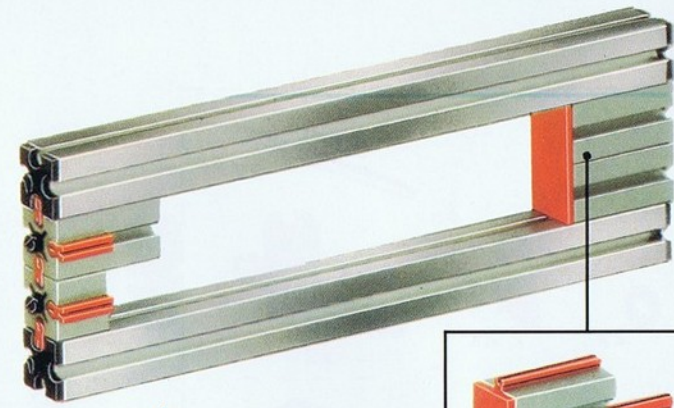
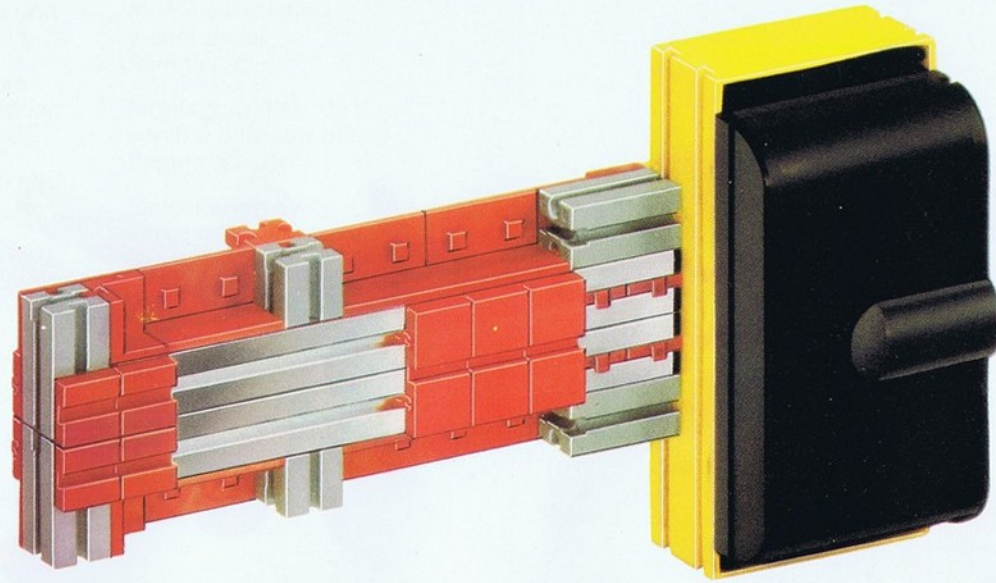
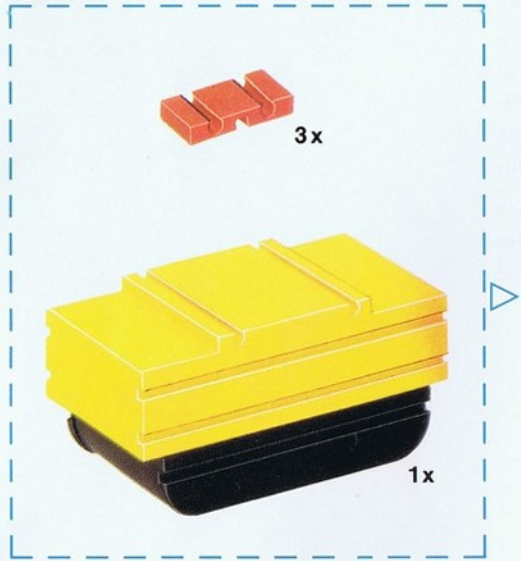

6

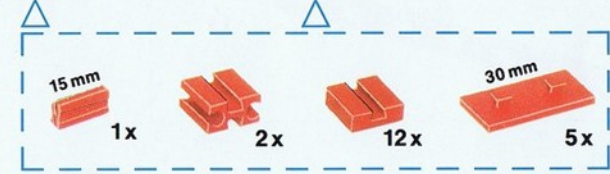
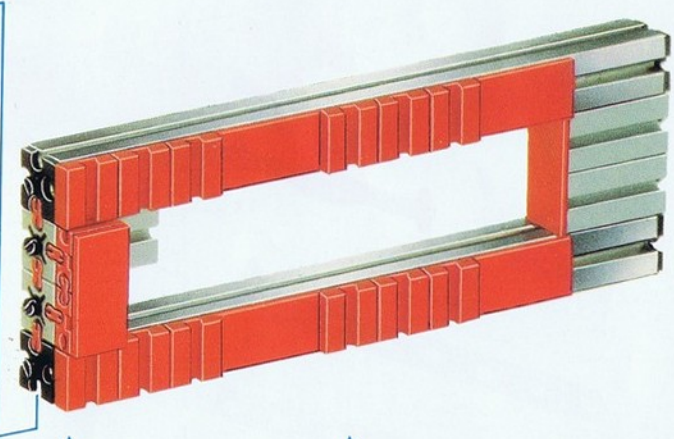
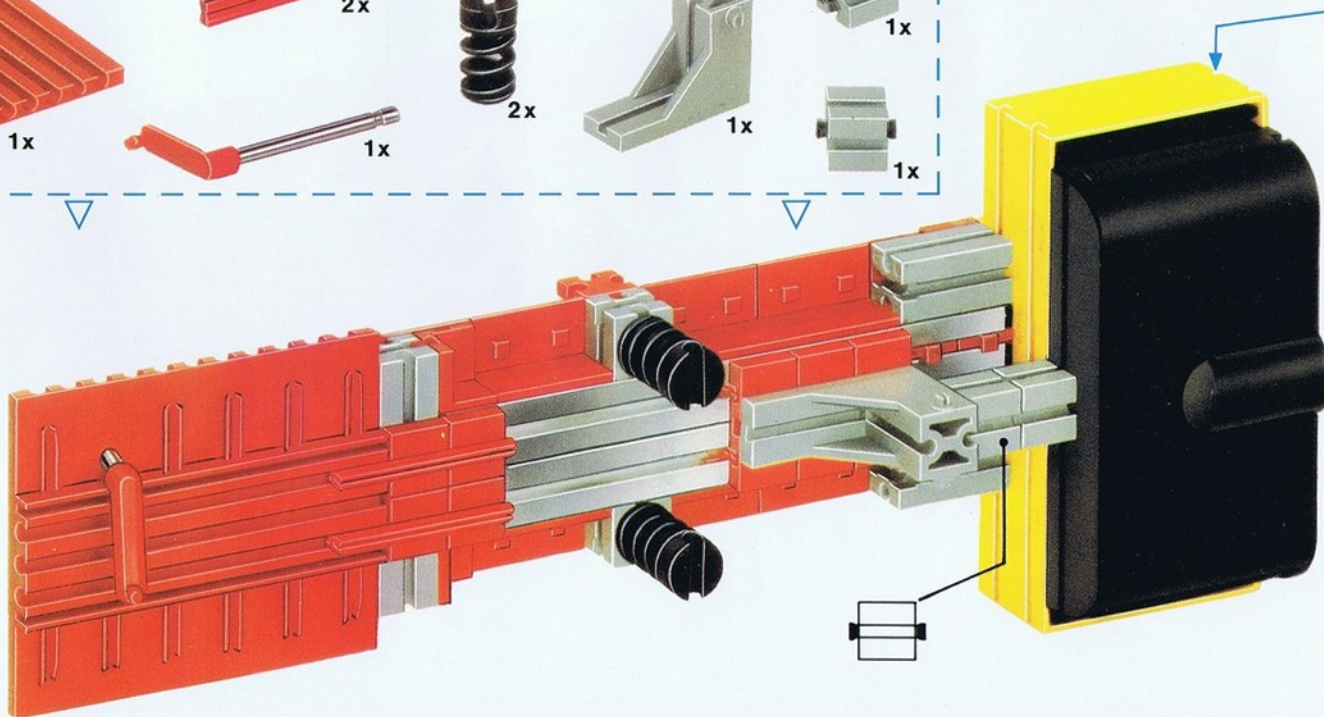
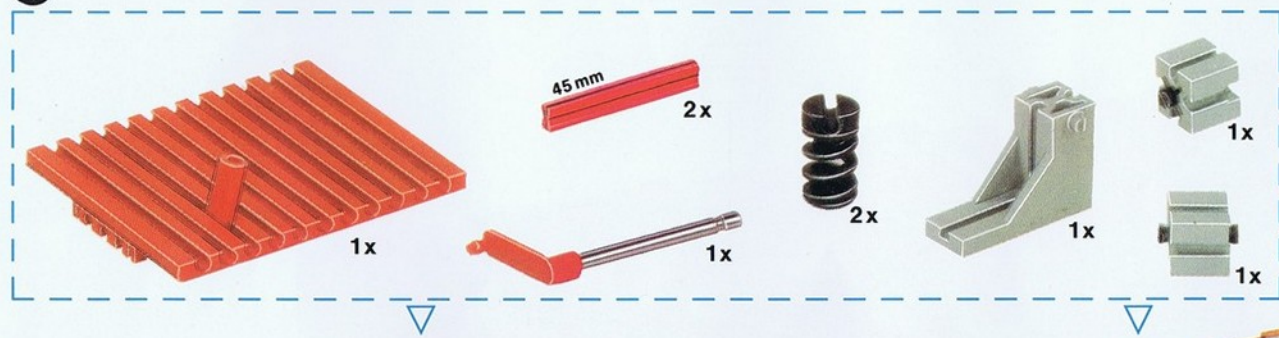

# 7

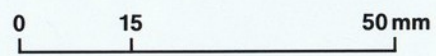
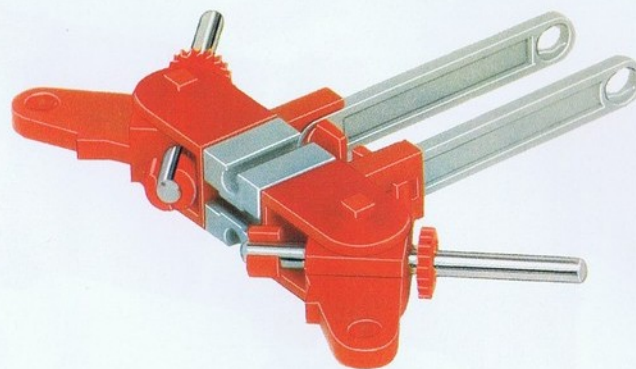
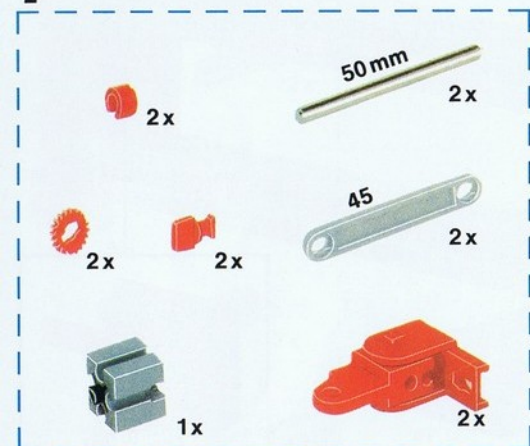

# 8

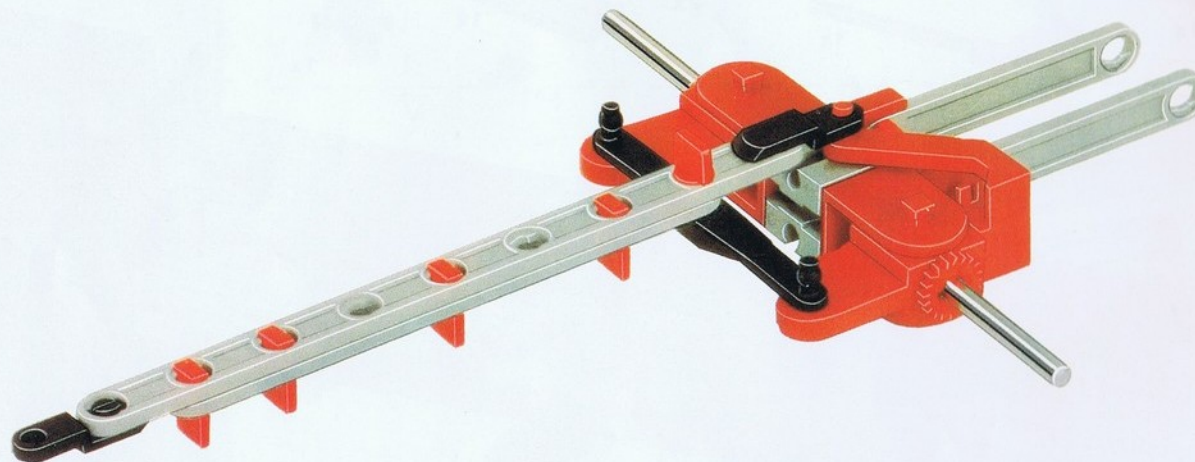
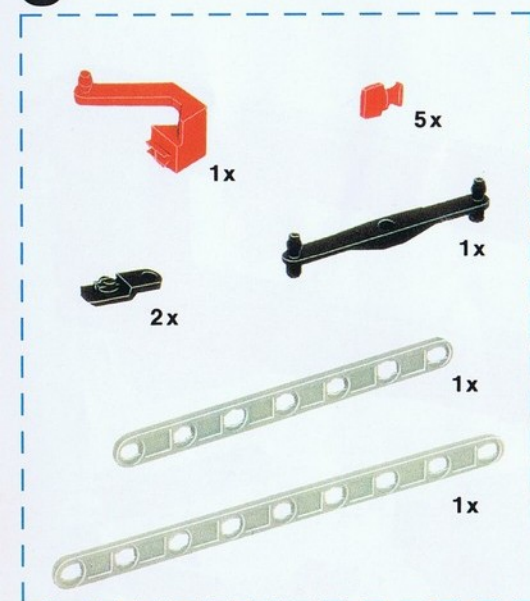

Einbau von Servo und Differential Seite 35-36.

Installation of servo facility and differential gearing. Page 35-36

Montage du servo et du différentiel. Pages 35-36

Montage van servomechanisme en differentieel op blz. 35-36.

Montaje del servo y diferencial. Páginas 35-36

Montaggio del servo e differenziale. Pagina 35-36

Inmontering av servo och differential sidorna 35-36.

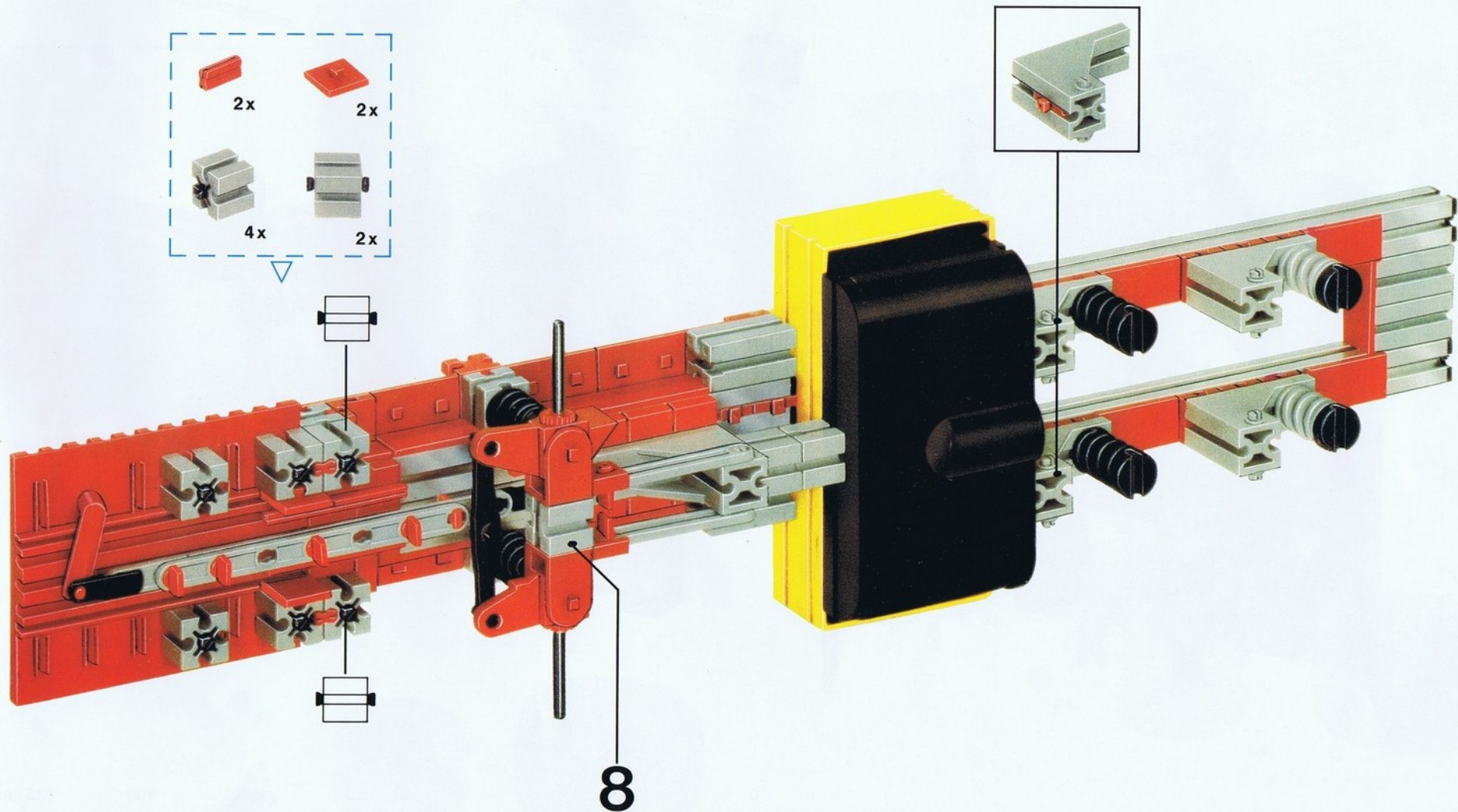
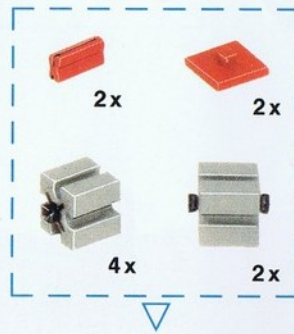
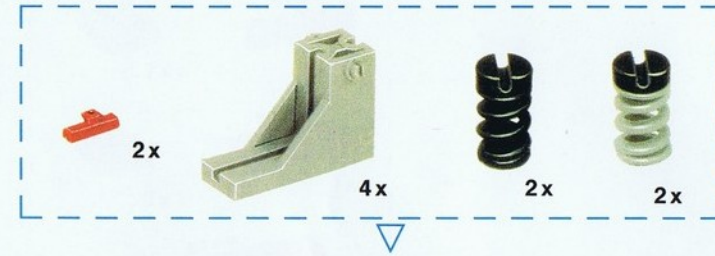

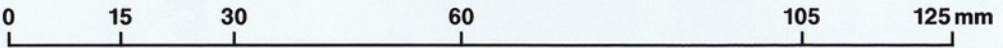
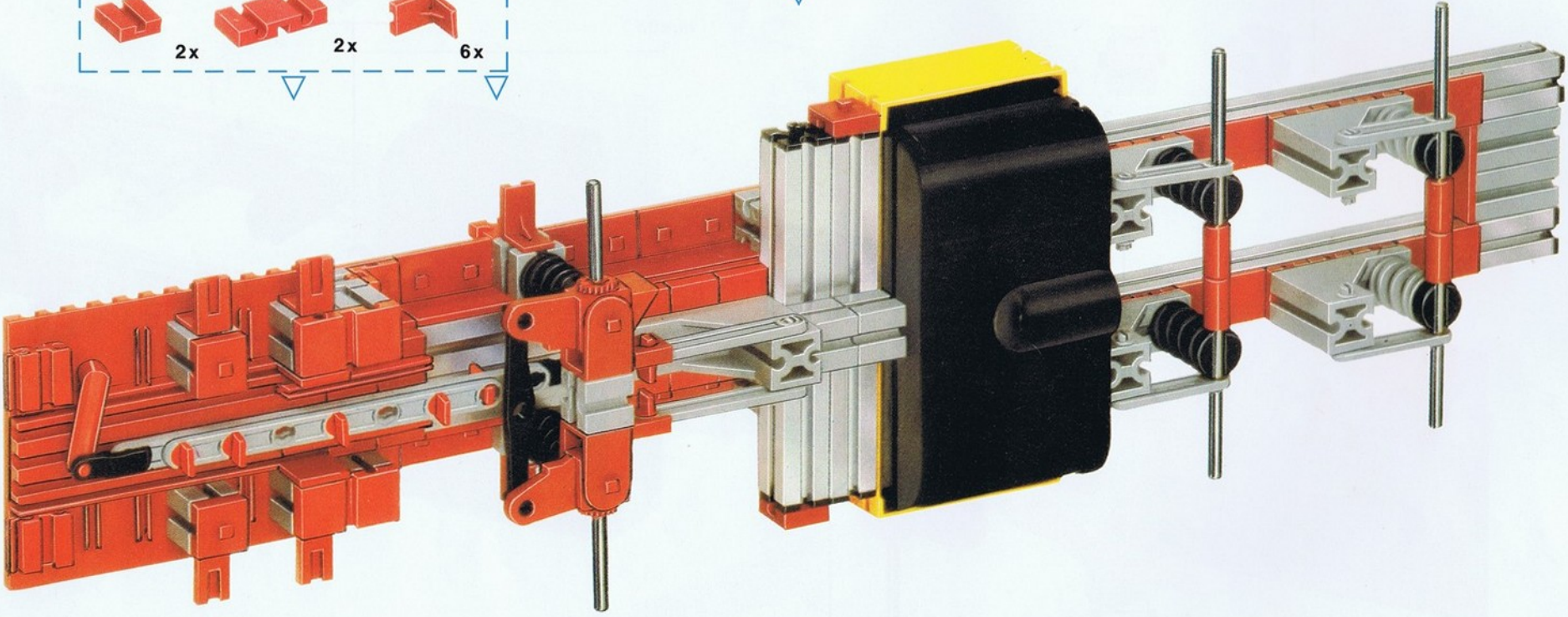
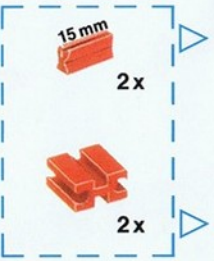
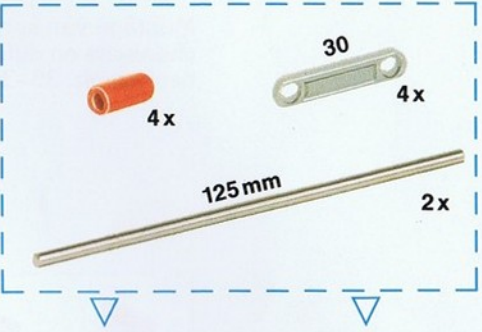
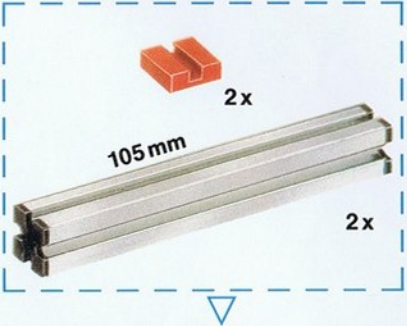
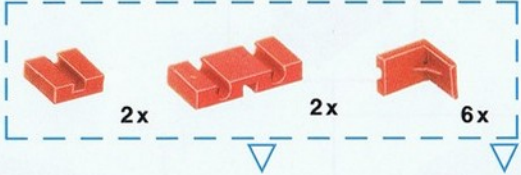



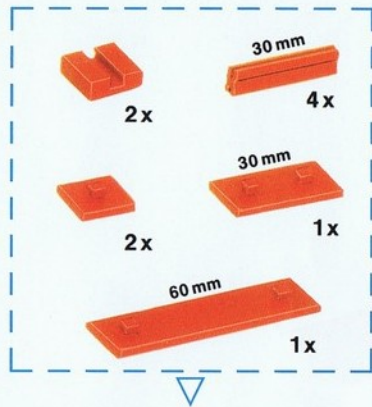
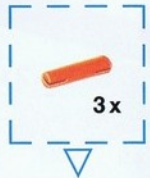
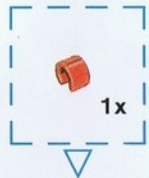
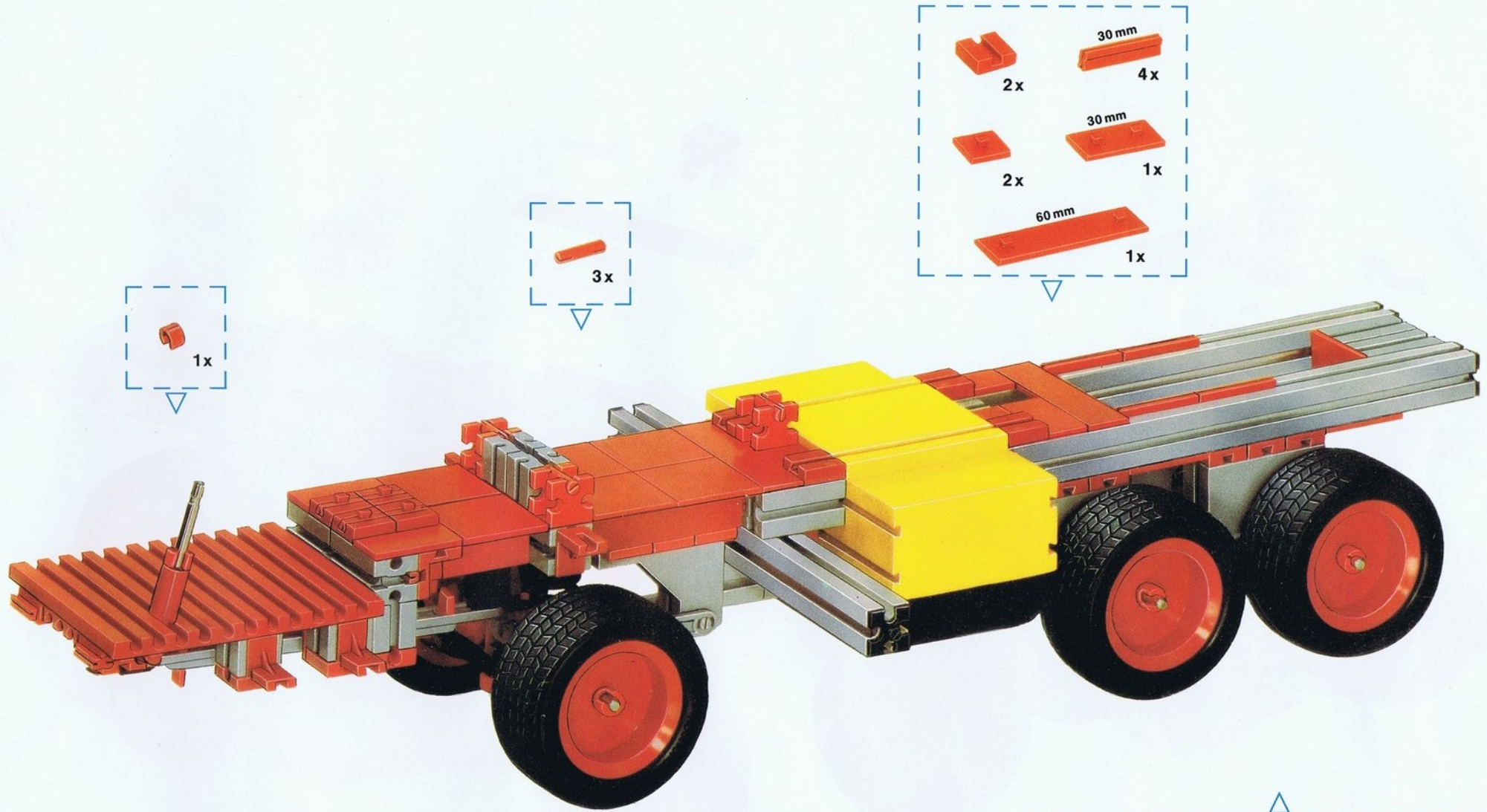

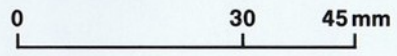
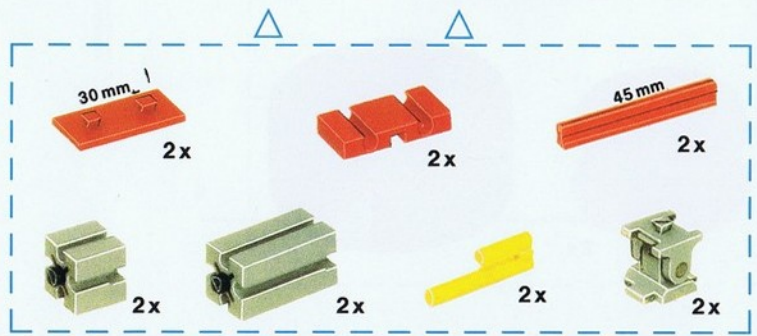
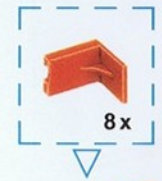
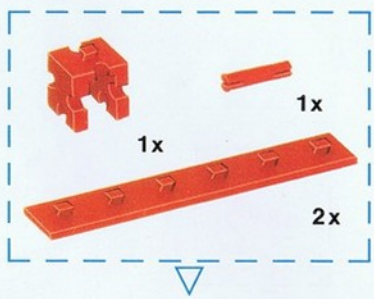
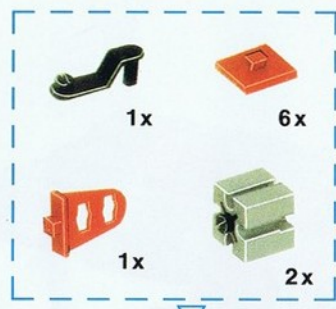
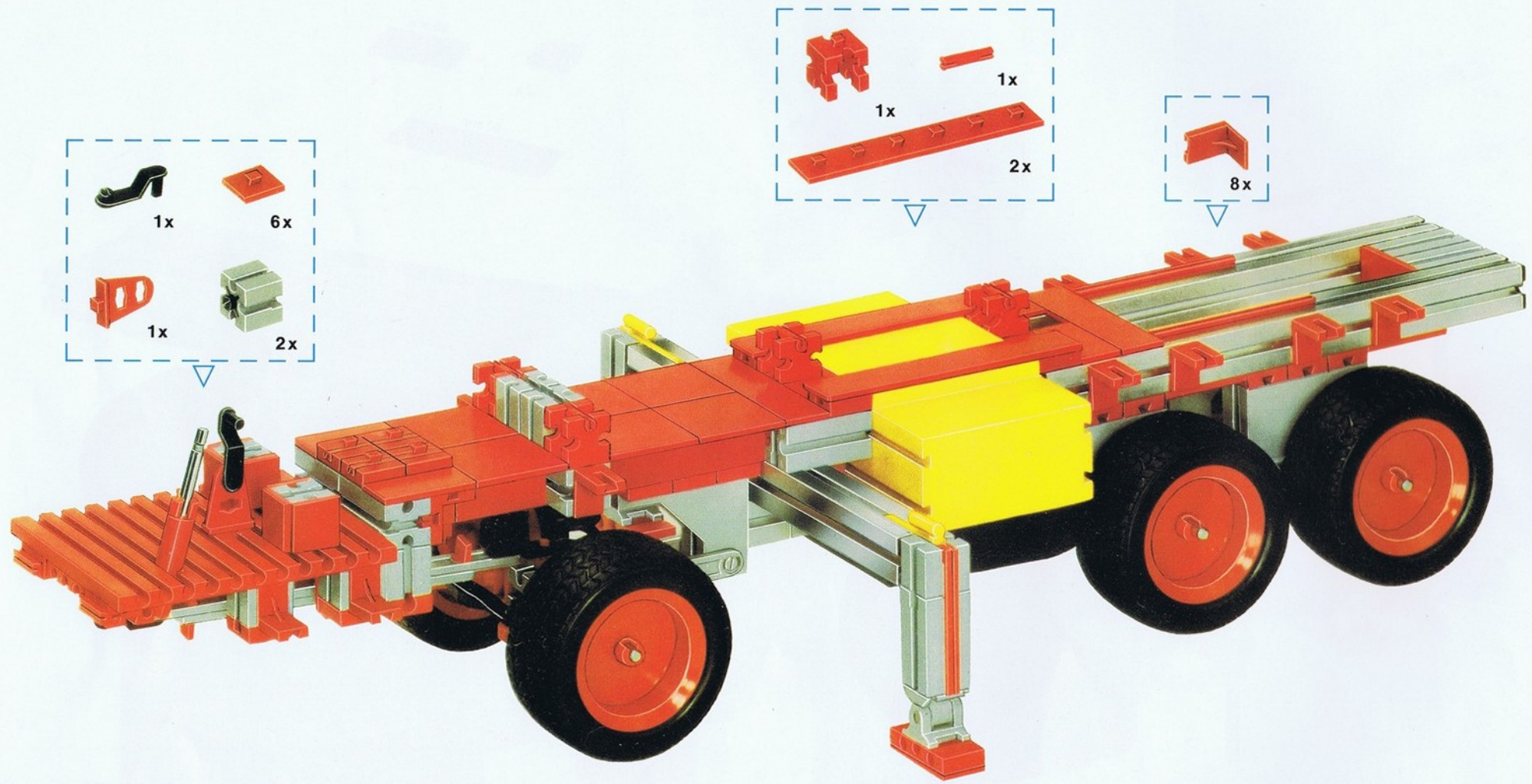

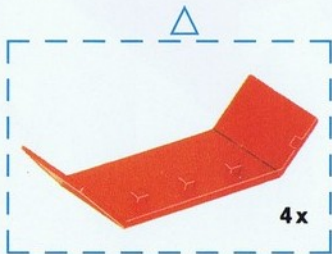
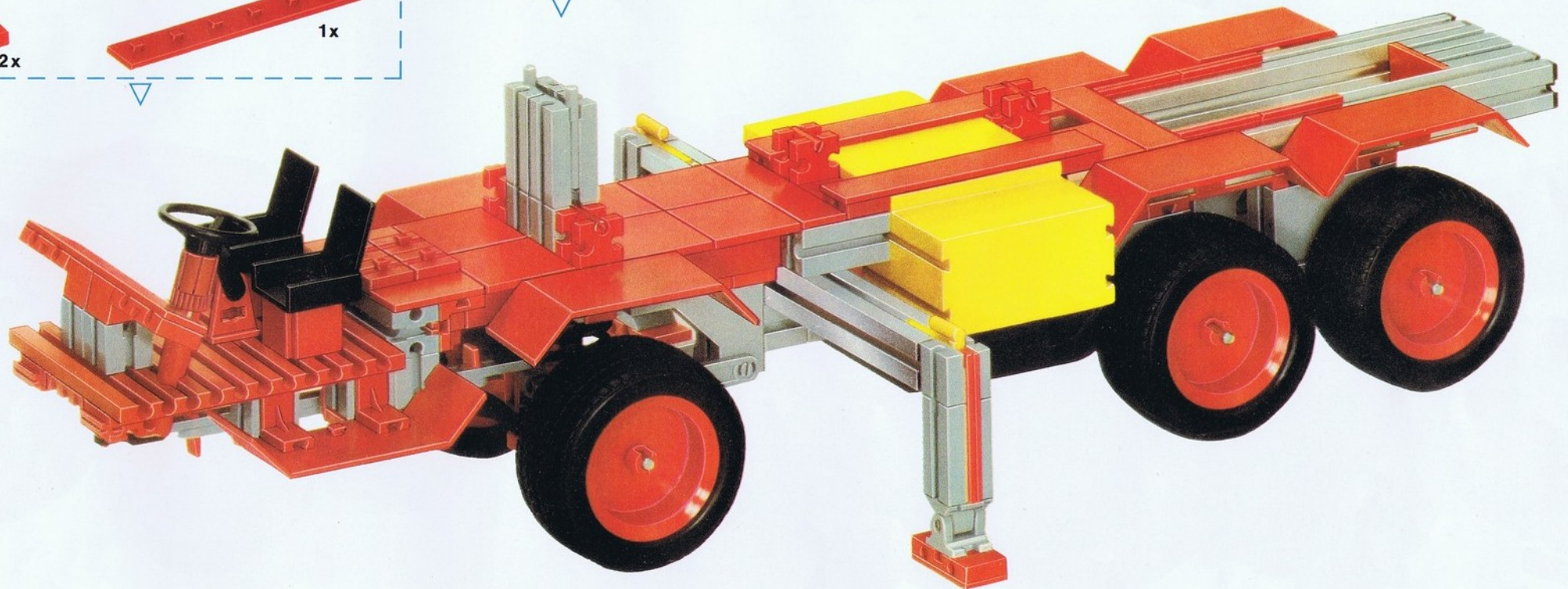
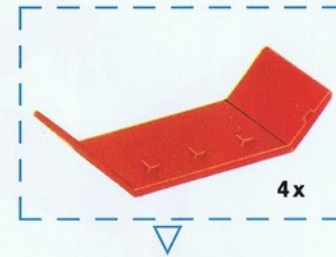
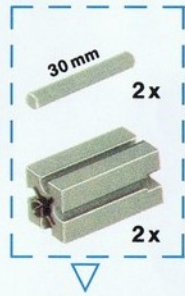
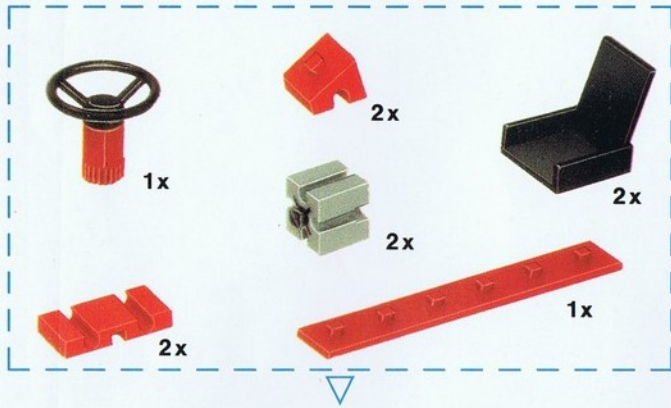

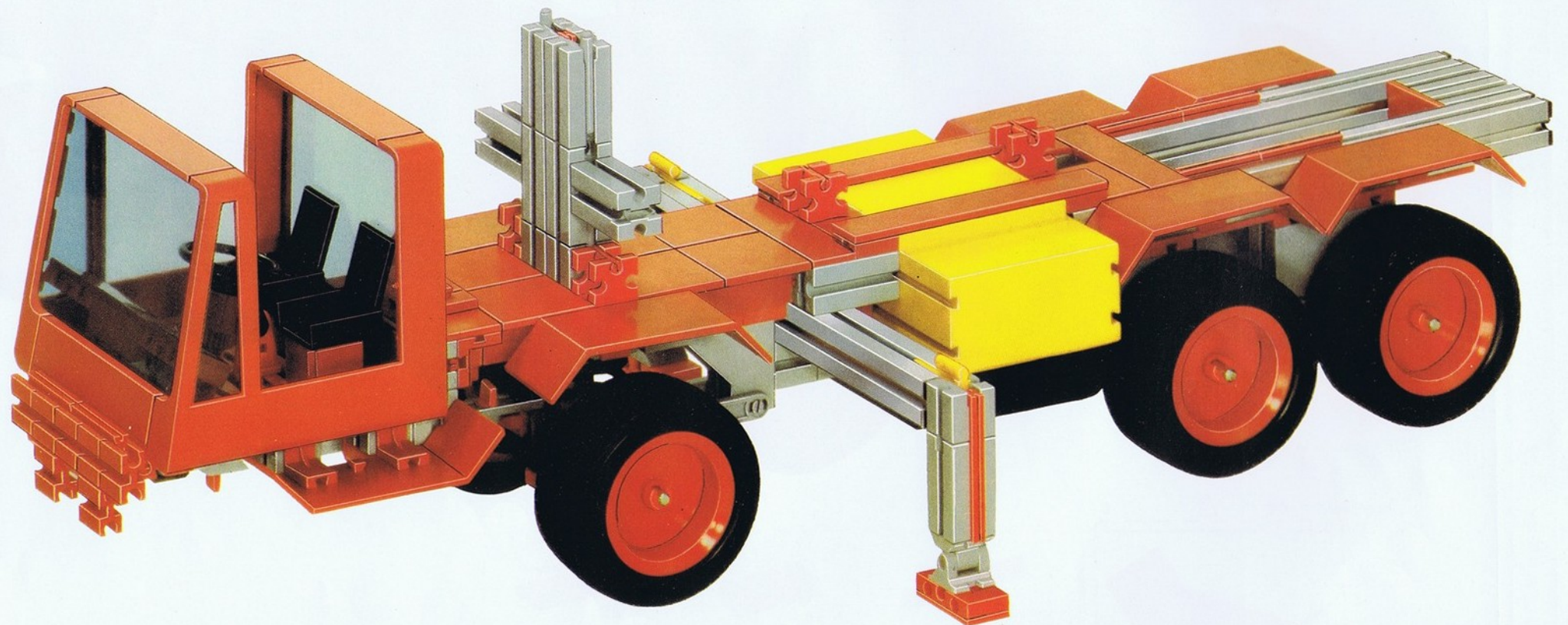
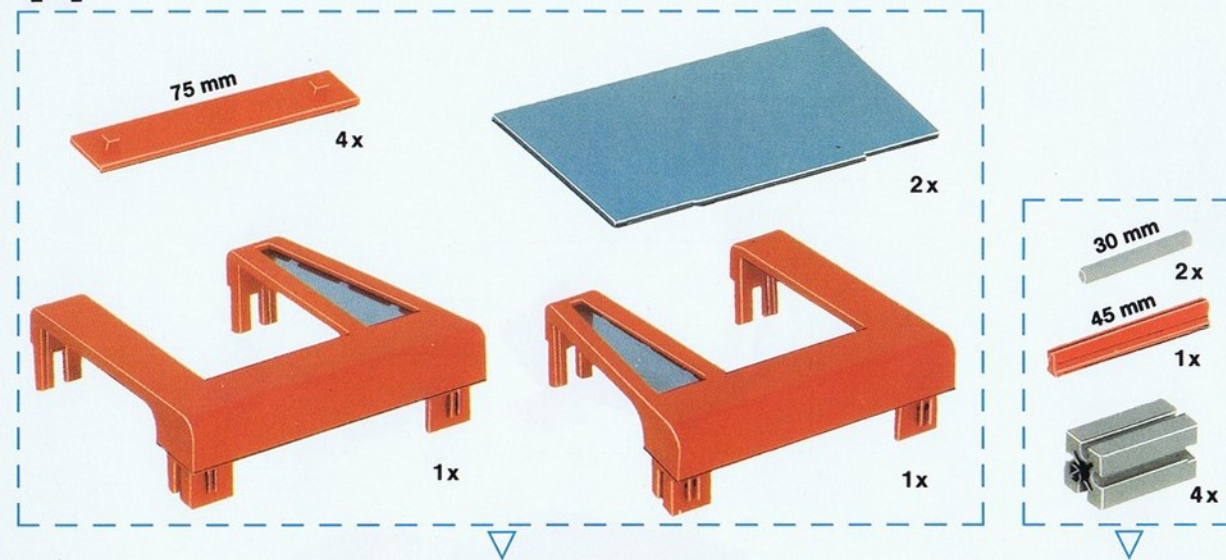

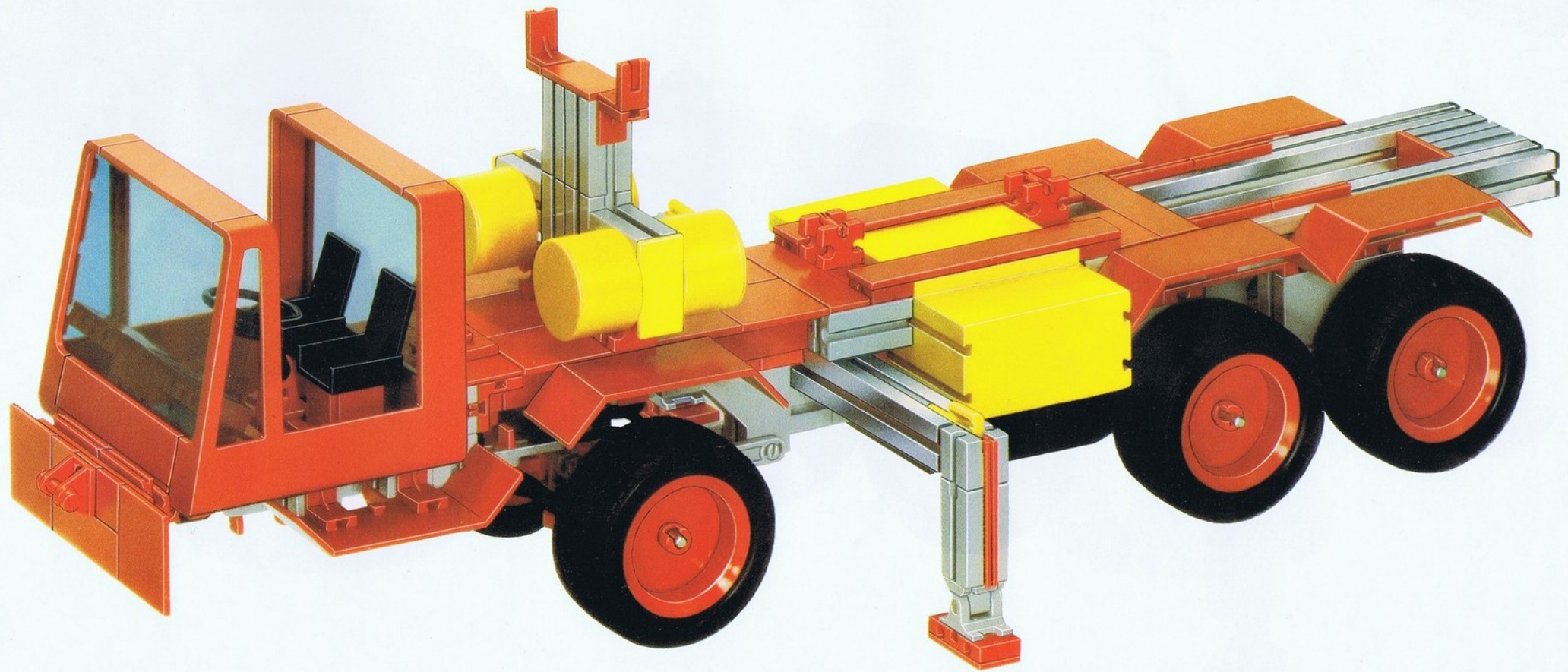
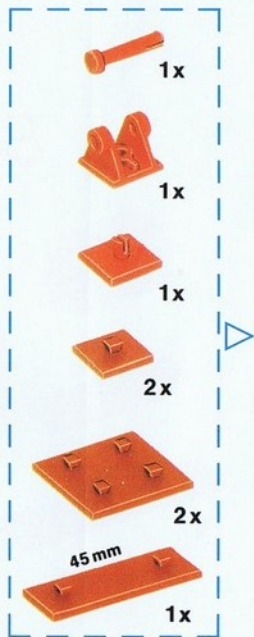
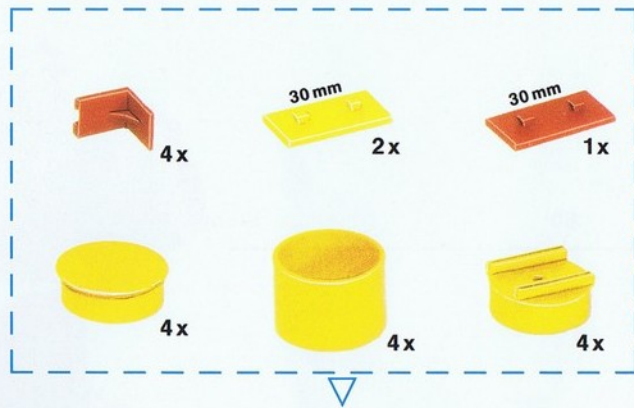

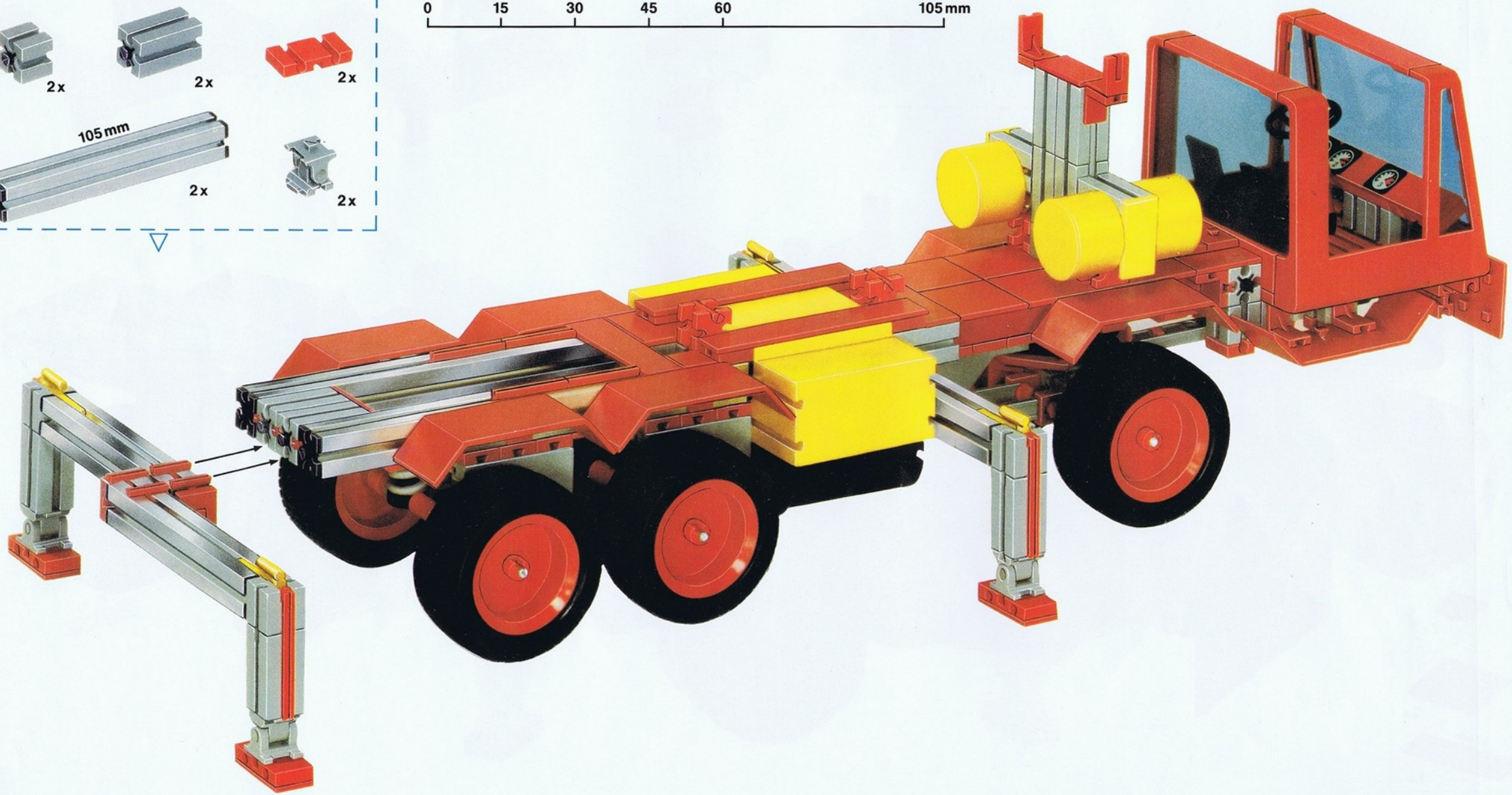
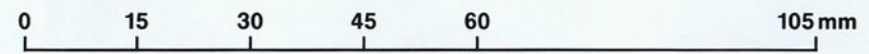
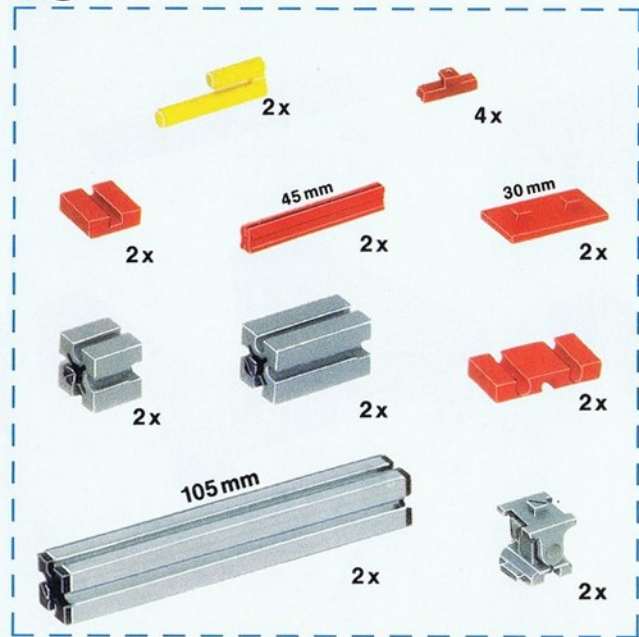

# 17

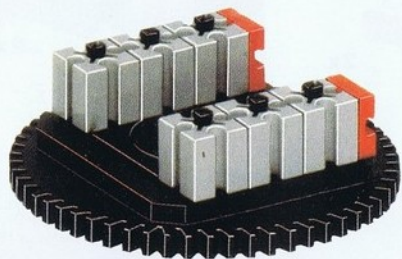
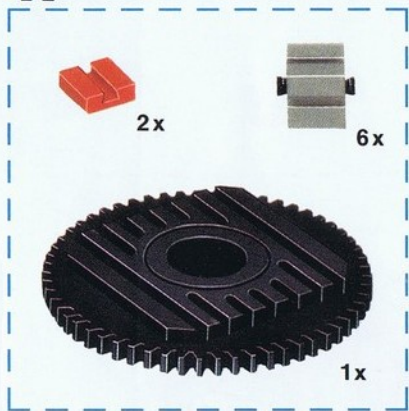

Rote Seite unten.  
 Red side downwards.  
 Voir pages rouges ci-dessous.  
 Rode kant onderaan.  
 Página roja abajo.  
 Lato rosso sotto.  
 Röd sida nere.

# 19

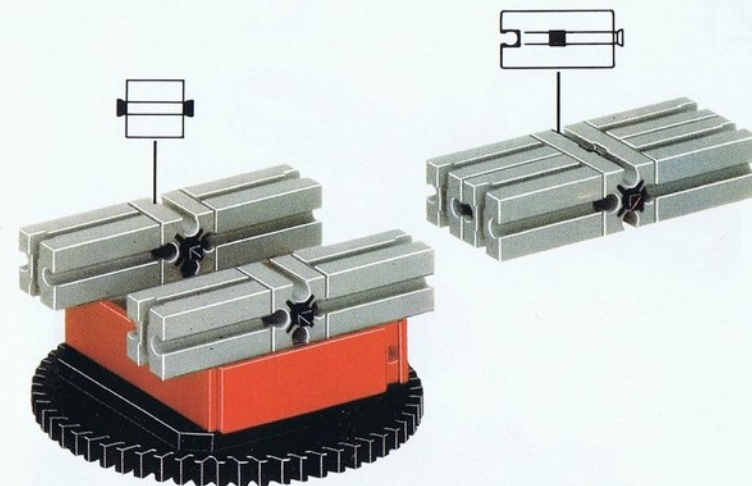
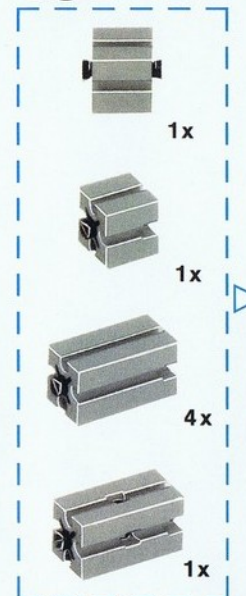

# 18

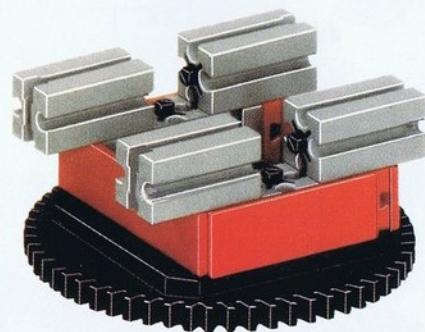
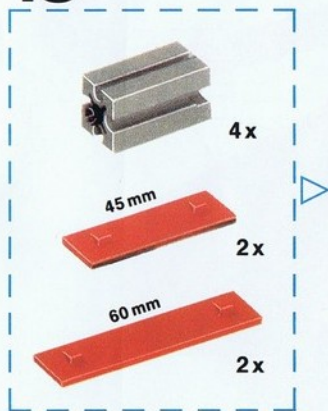

# 20

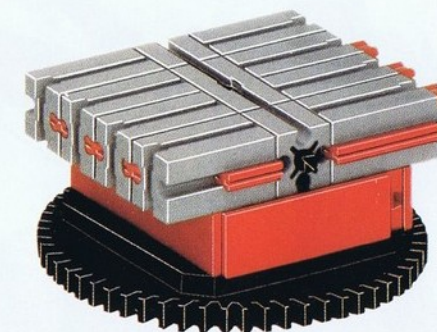
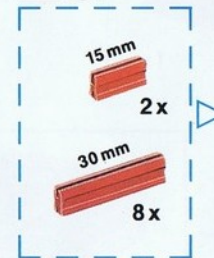

# 21

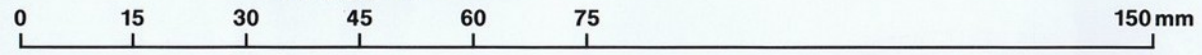
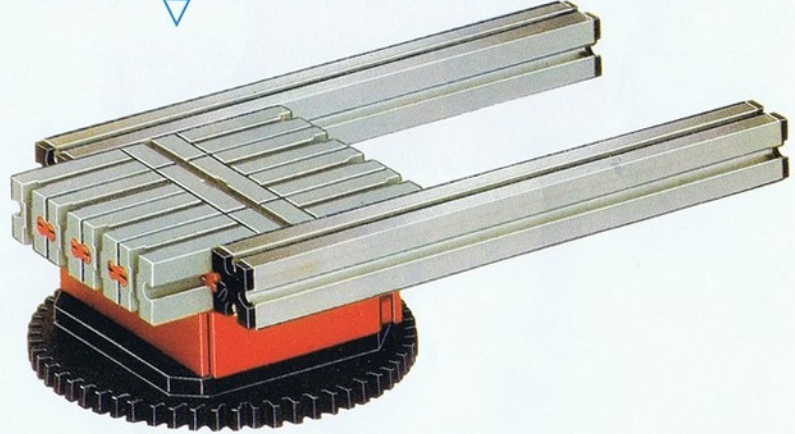
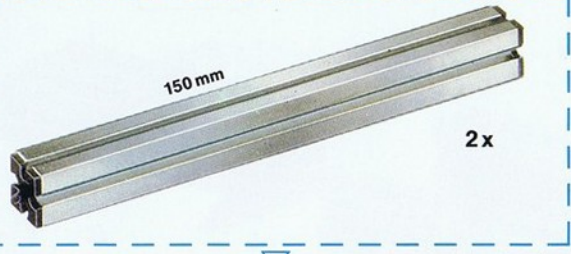

# 23

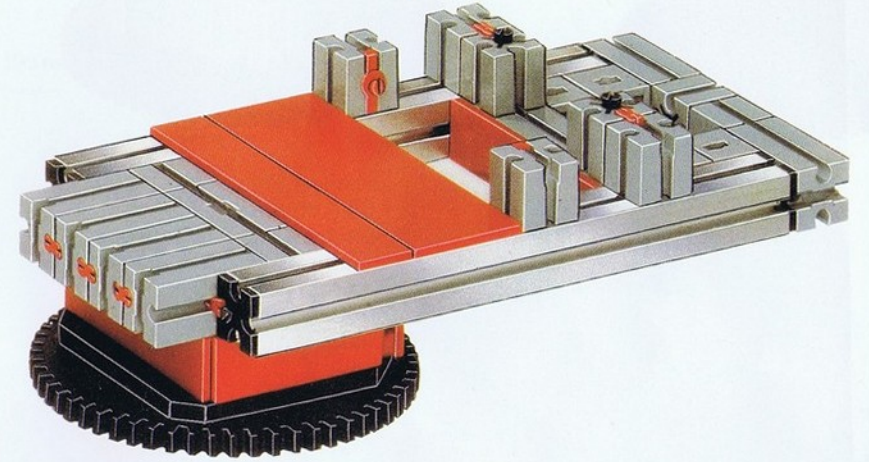
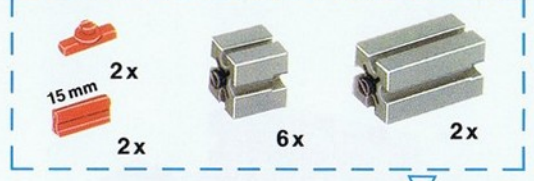

# 22

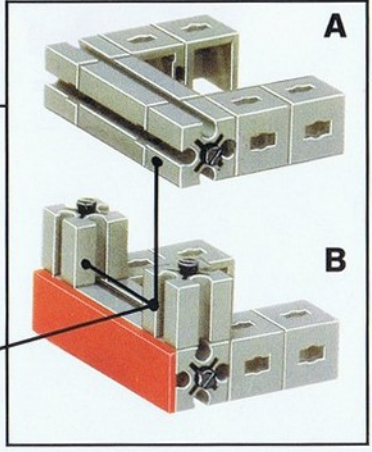
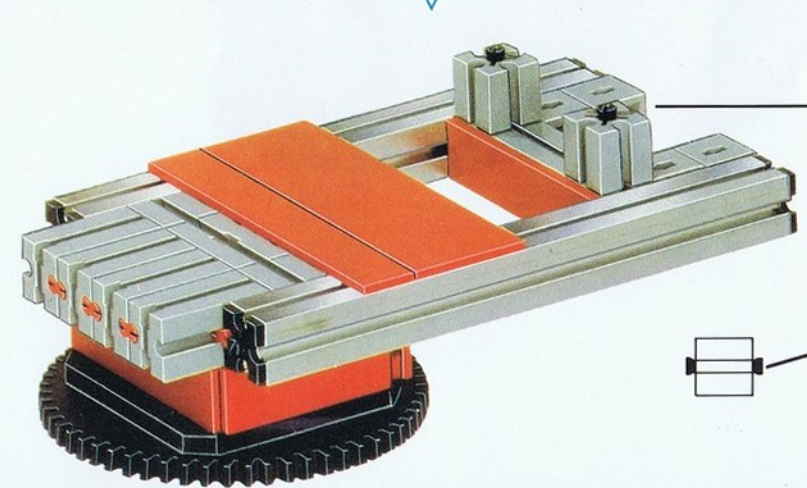
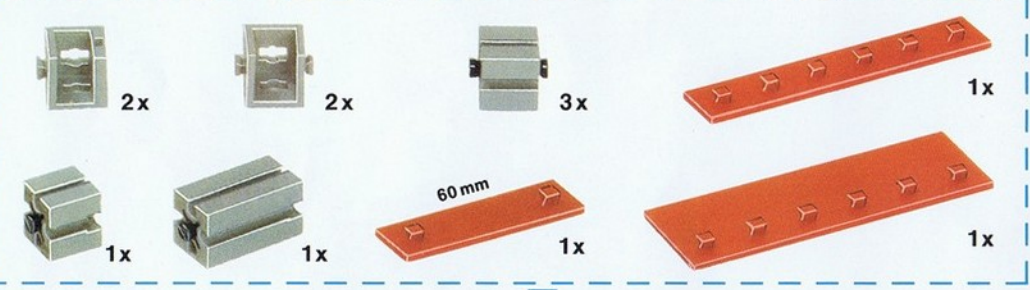

# 24

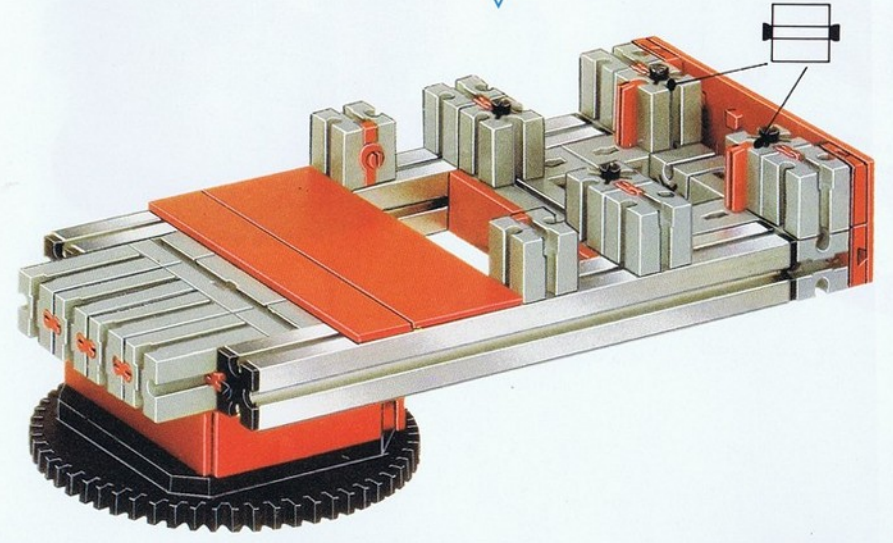
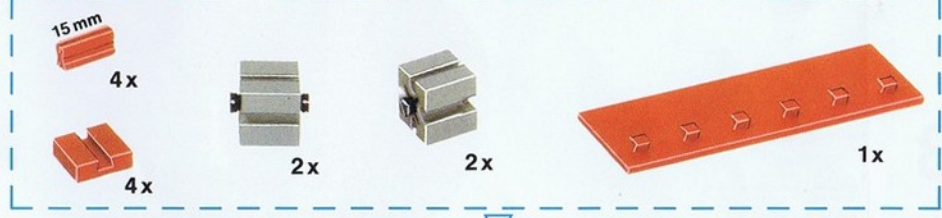



25

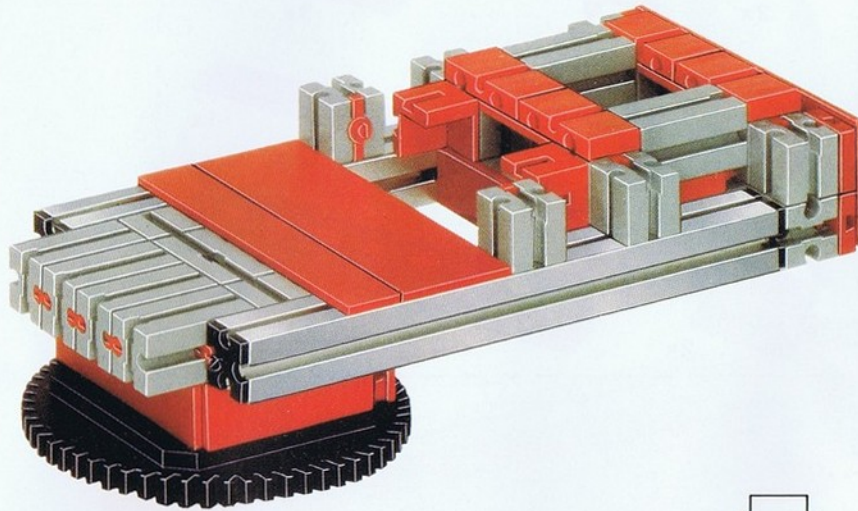
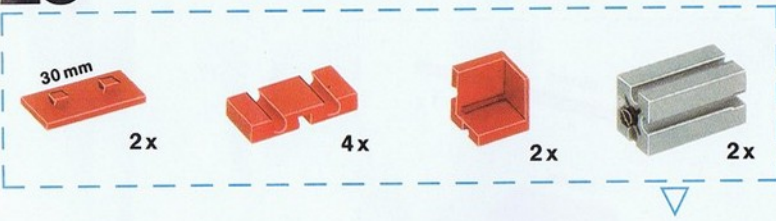

26

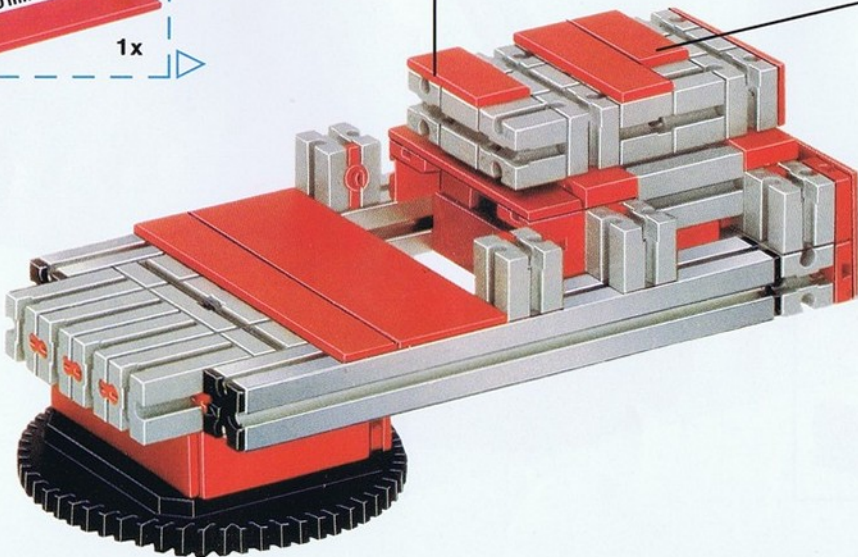
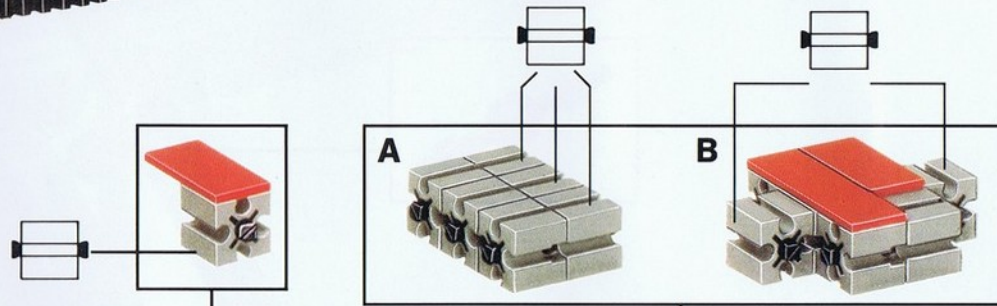
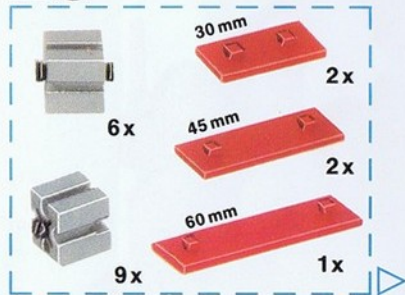

27

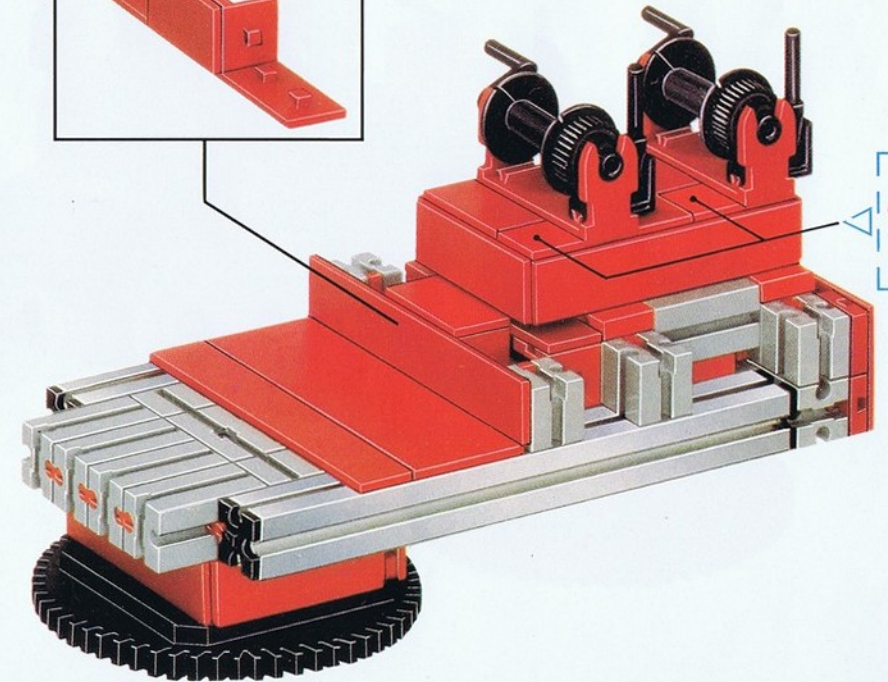
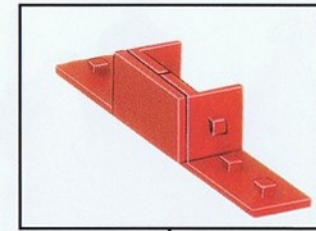
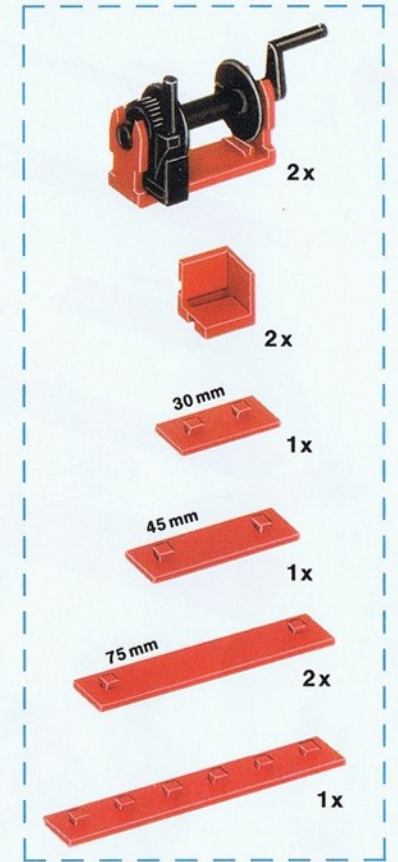

28

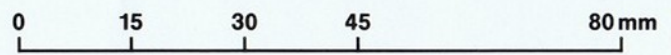
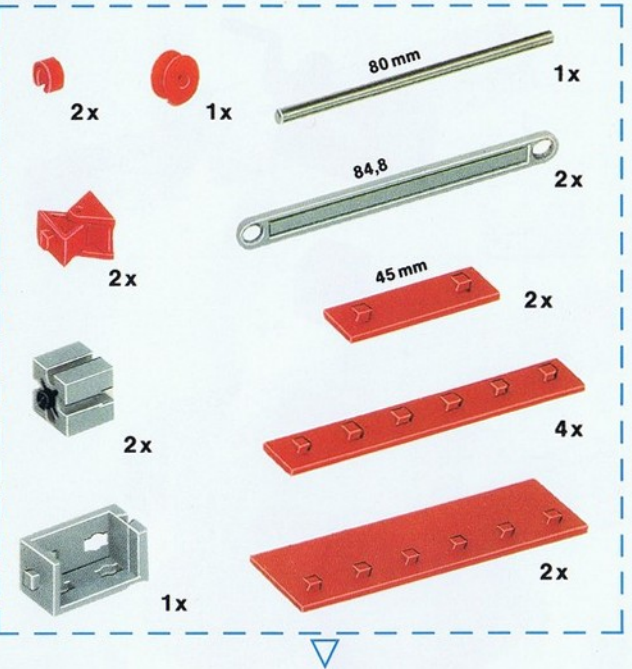

29

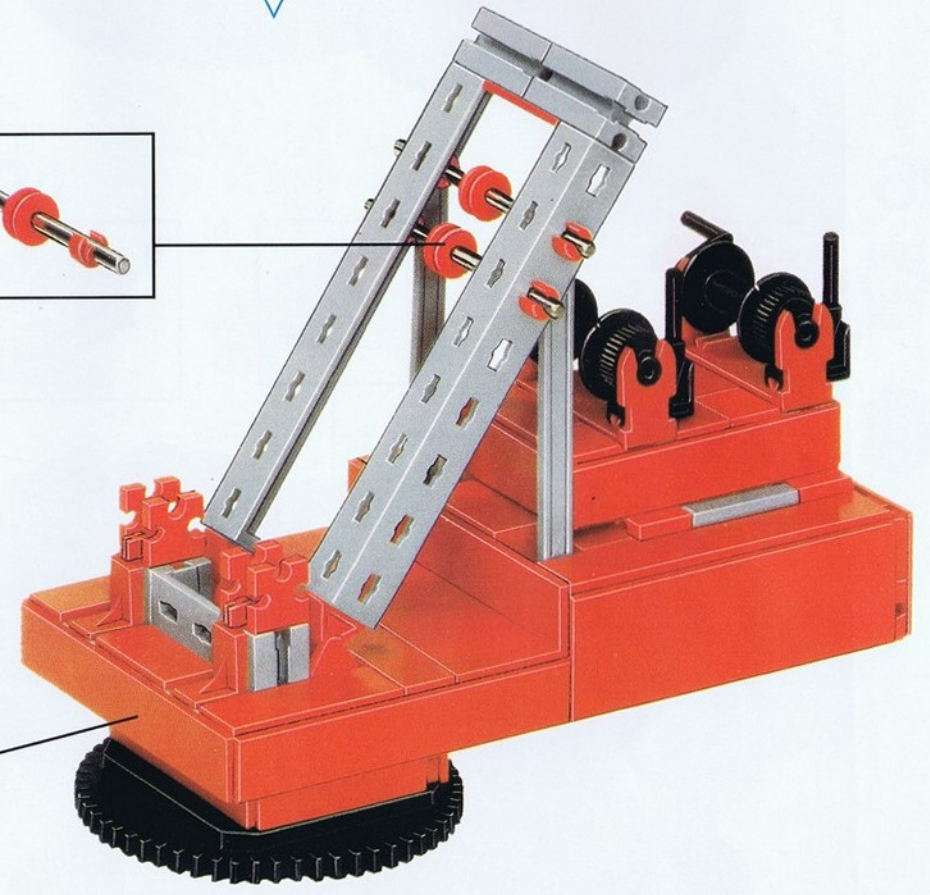
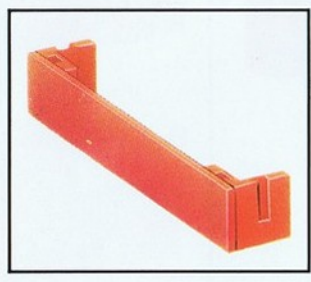
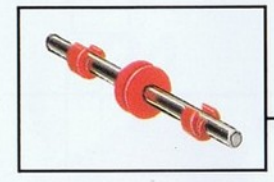
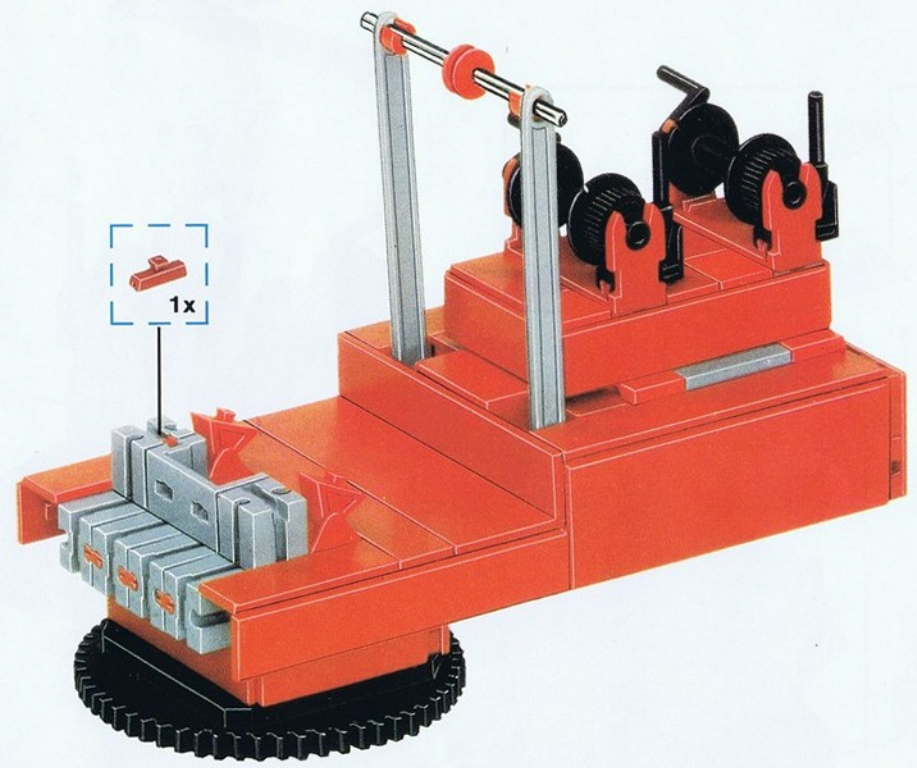
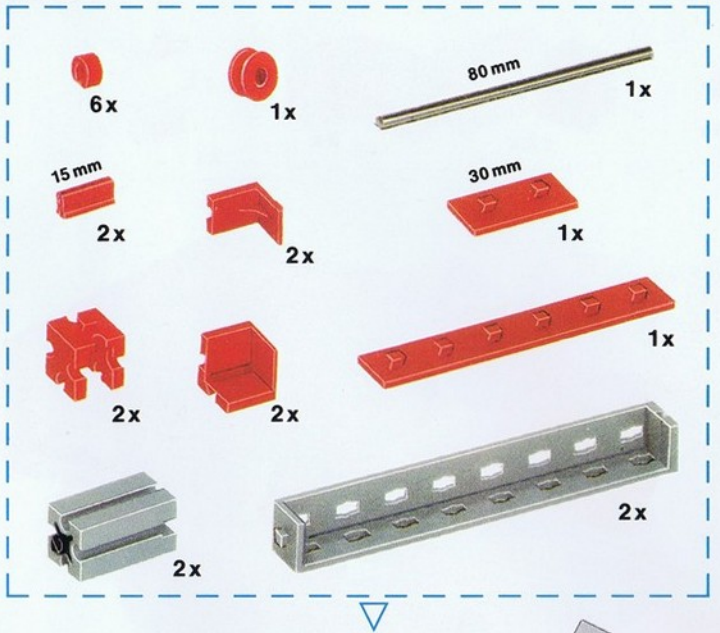

Teleskop-Mobilkran  
Heavy duty crane truck  
Grue télescopique mobile  
Teleskoopkraanwagen  
Camión grúa telescópica  
Gru telescopica semovente  
Teleskop-Mobilkran

## **Baustufen 30-37**

Bauplatte 45 mm durch Spezialbauplatte ersetzen.

## **Series of constructional steps 30-37**

Substitute mounting plate 45 mm by special mounting plate.

## **Etapes du montage 30-37**

Remplacer la plaque de construction de 45 mm par la plaque spéciale.

## **Konstruktiedelen 30-37**

De bouwplaat van 45 mm door de speciale bouwplaat vervangen.

## **Etapas de montaje 30-37**

Substituir la placa de montaje de 45 mm por una placa especial.

## **Stadi di costruzione 30-37**

Sostituire la piastra di costruzione 45 mm con la piastra speciale.

## **Monteringssteg 30-37**

Konstruktionsplatta 45 mm ersätts med specialplatta.

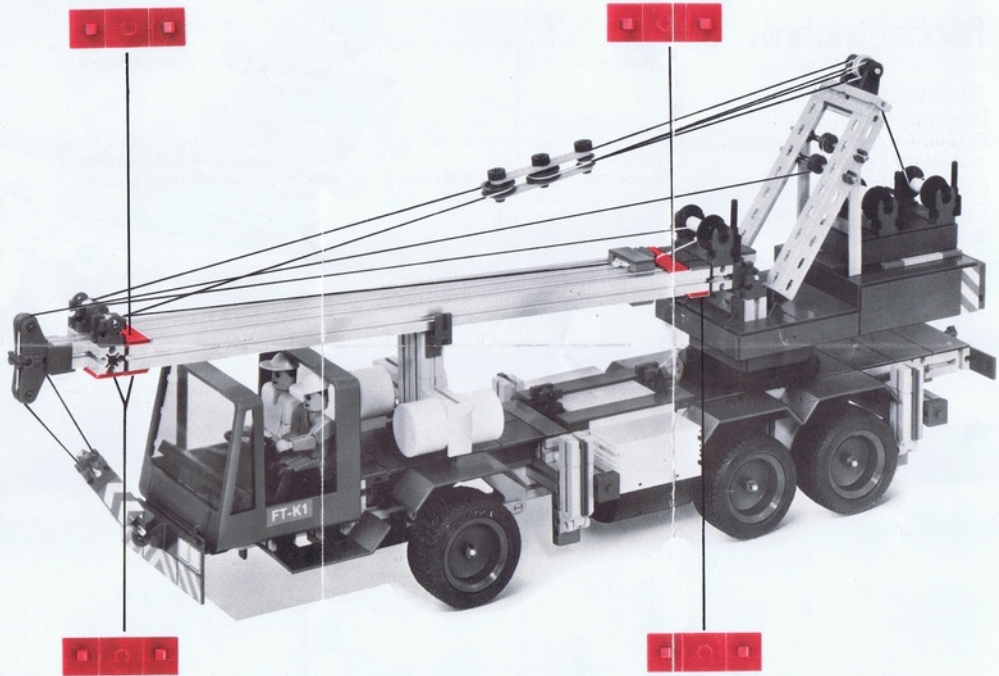

30

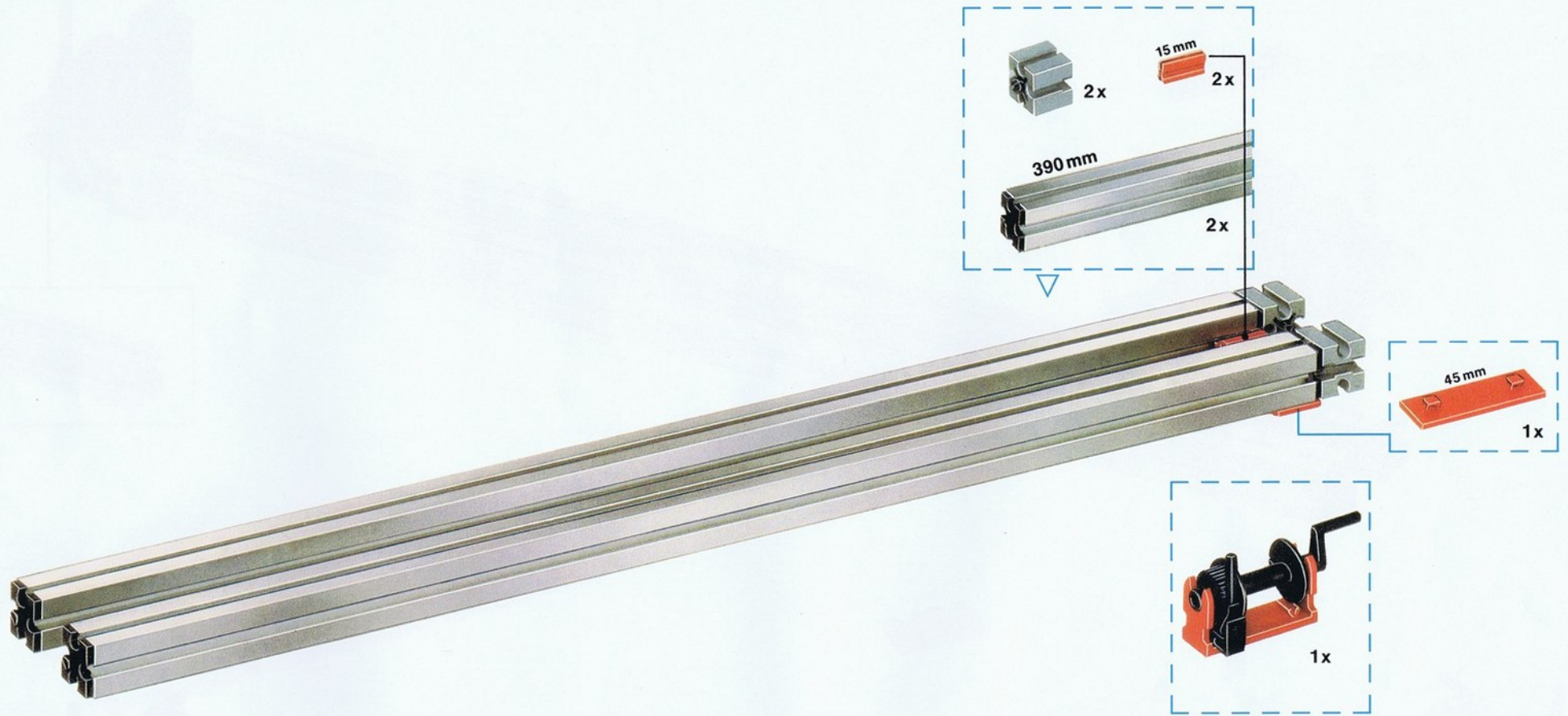

31

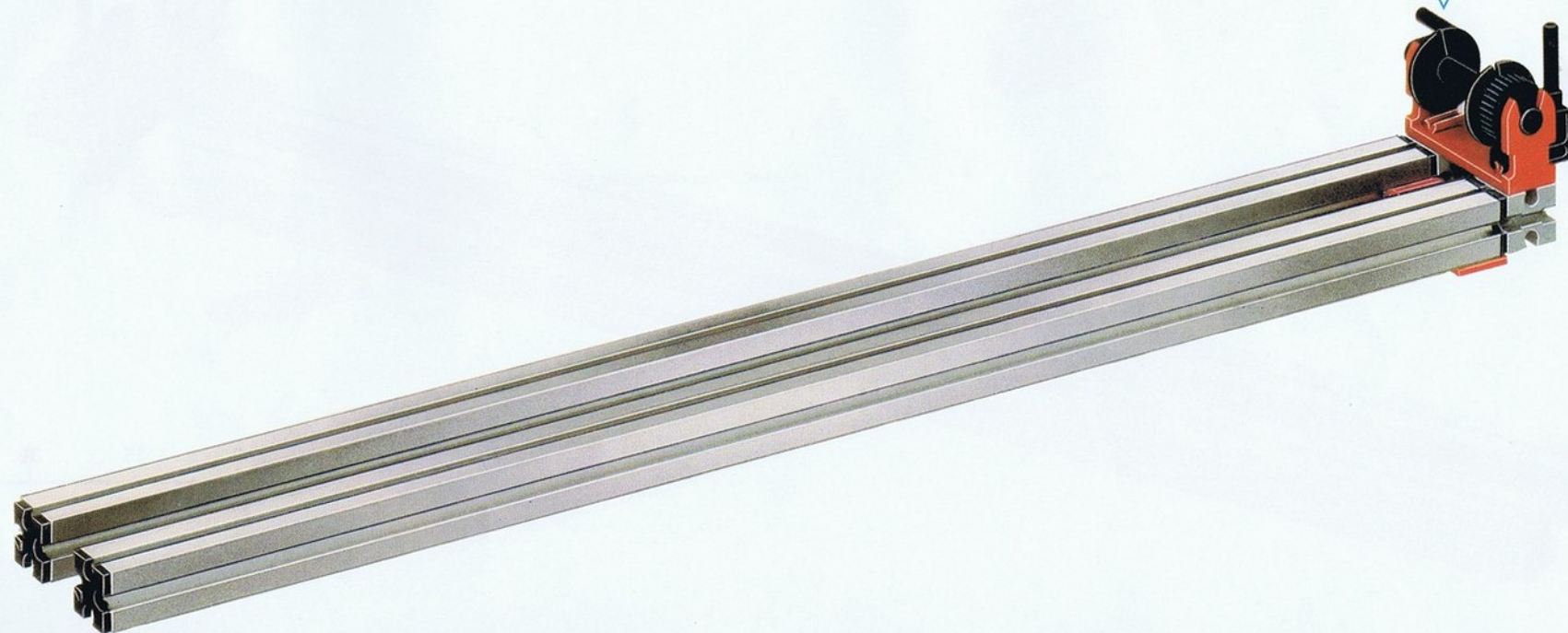

32

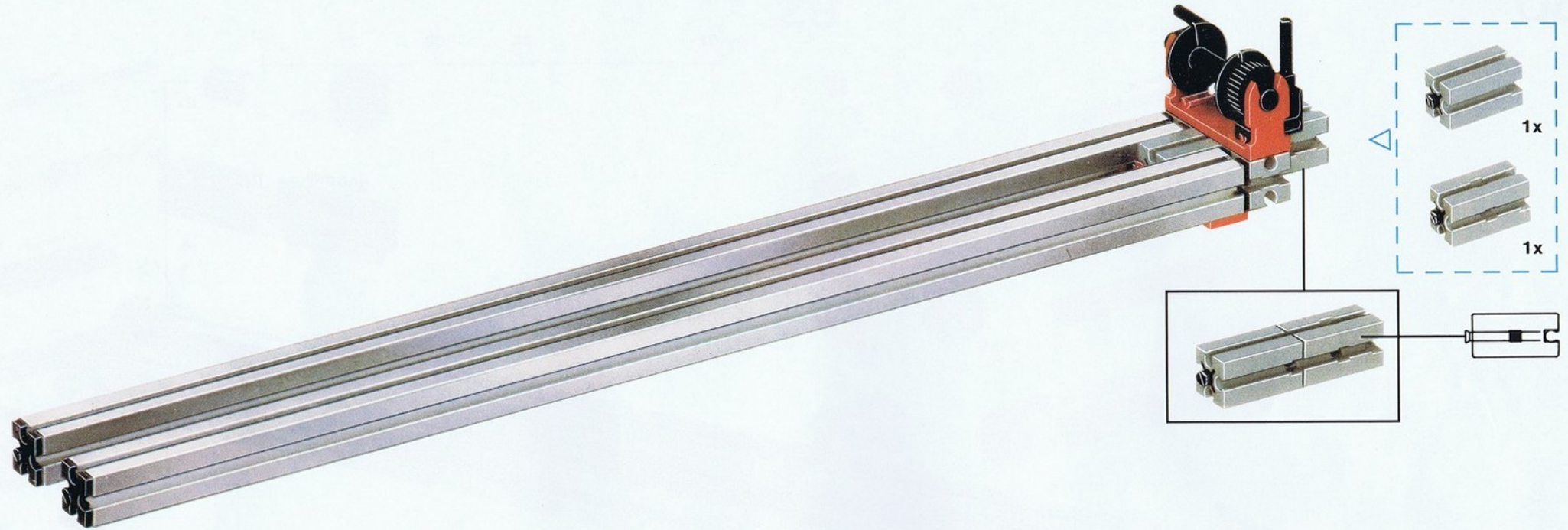

33



34

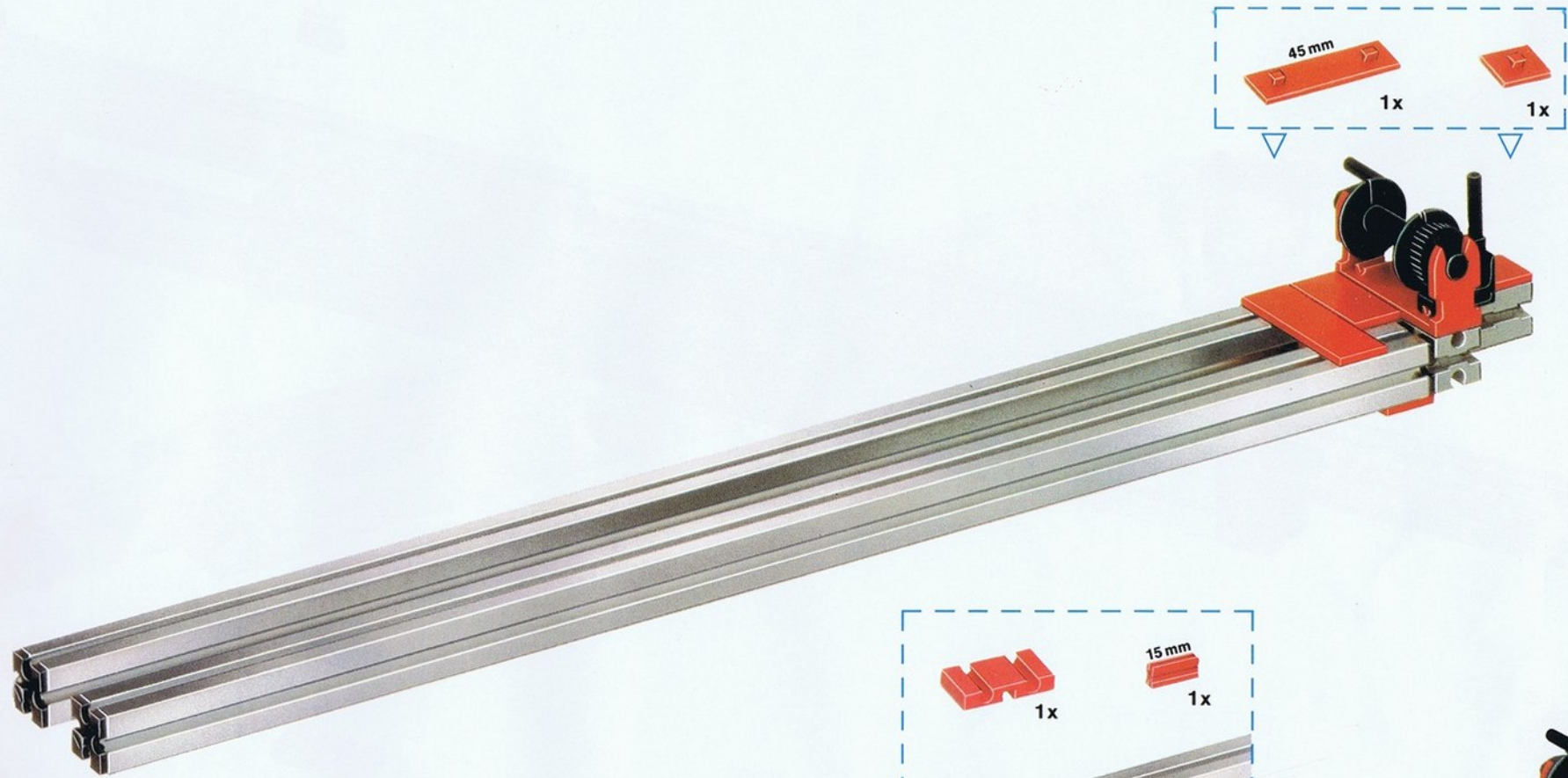

35

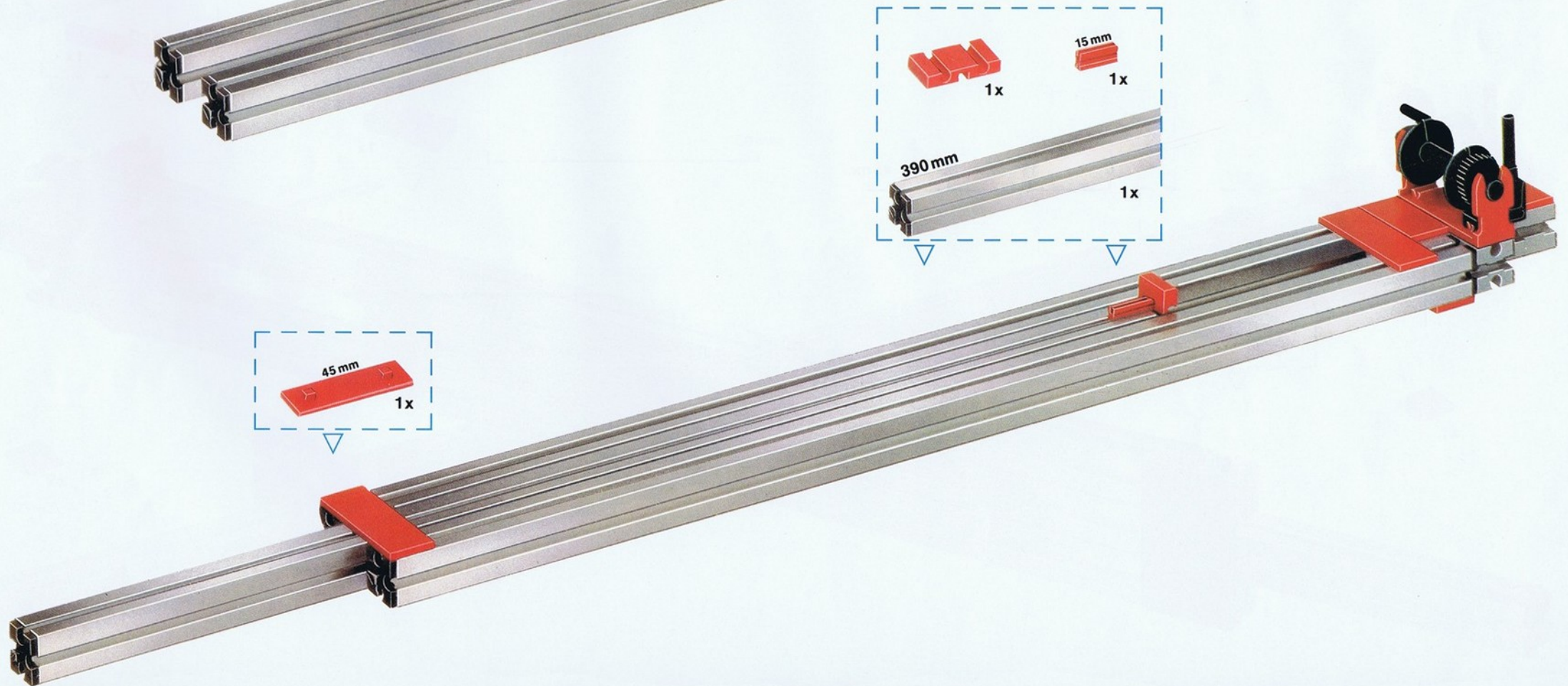

36

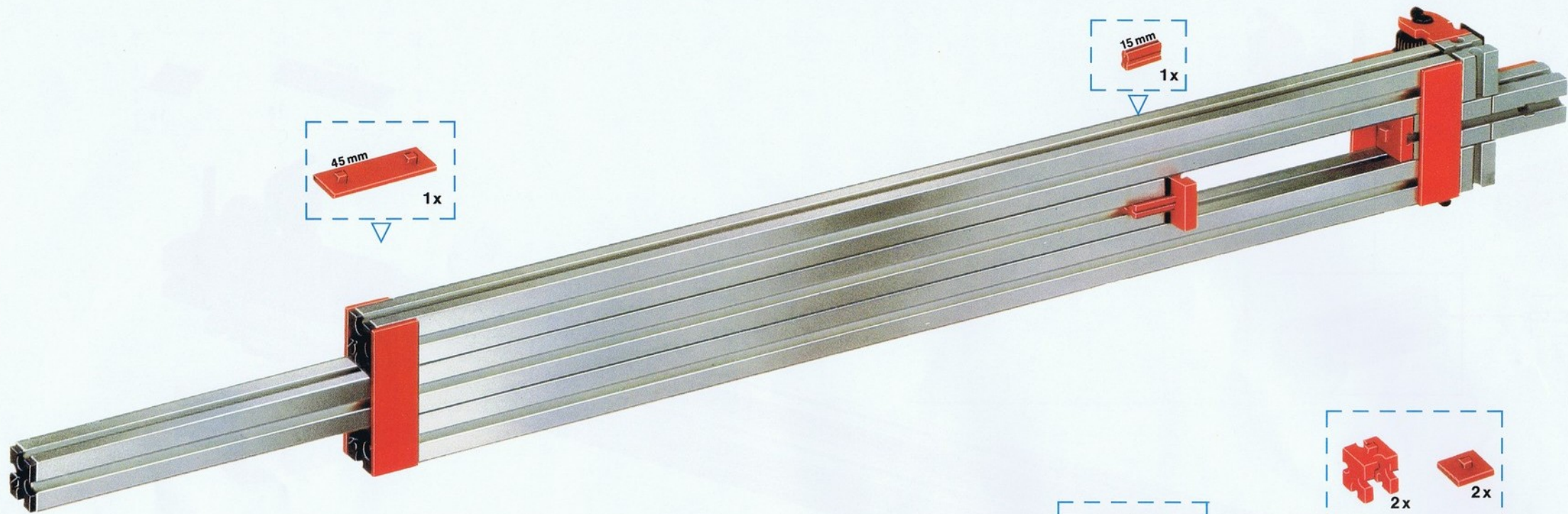

37

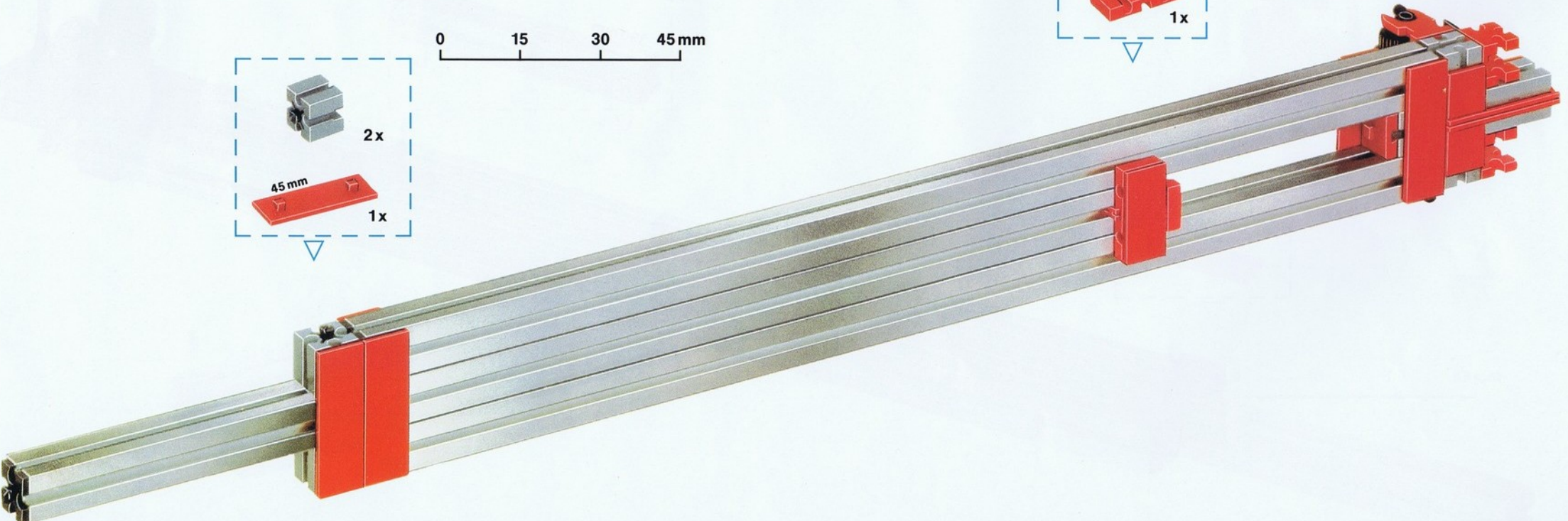



38

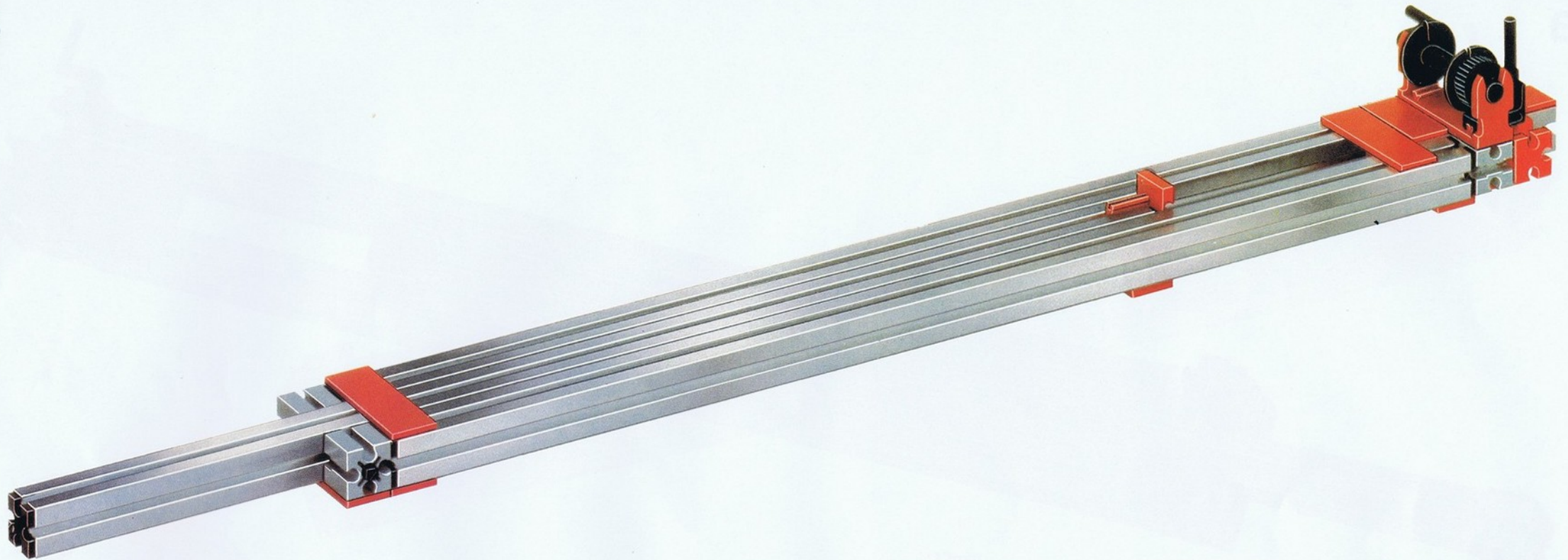

39

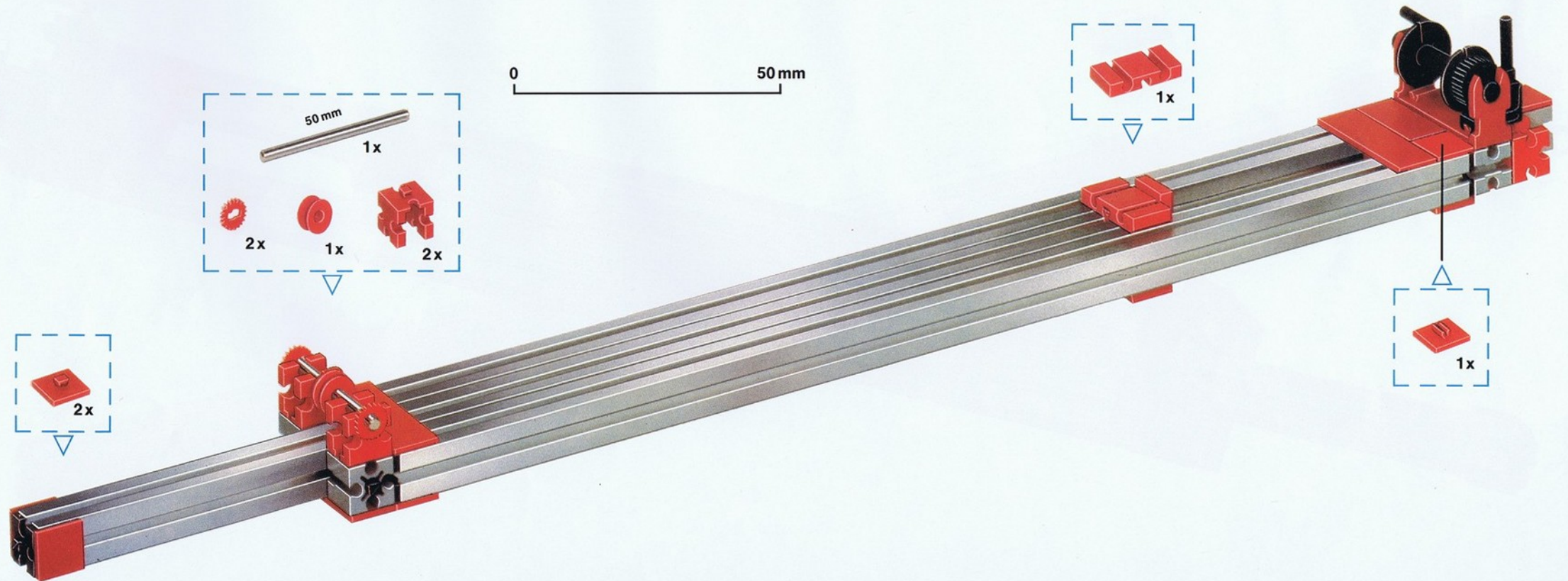

40a

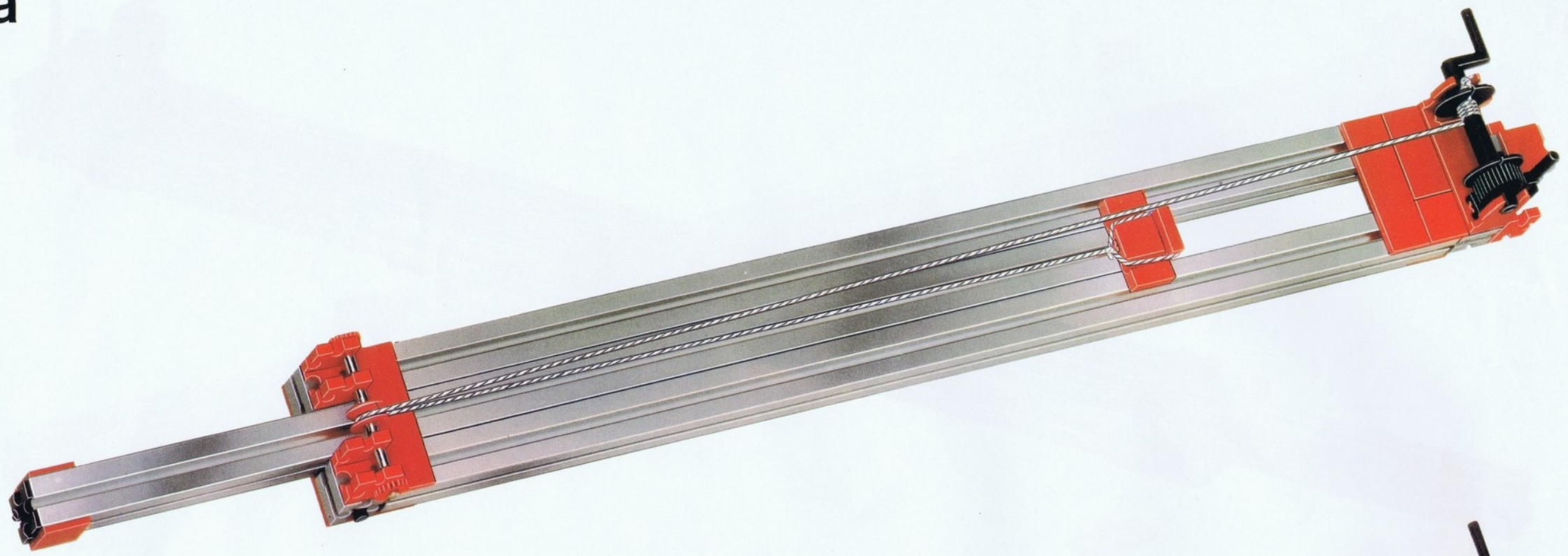

40b

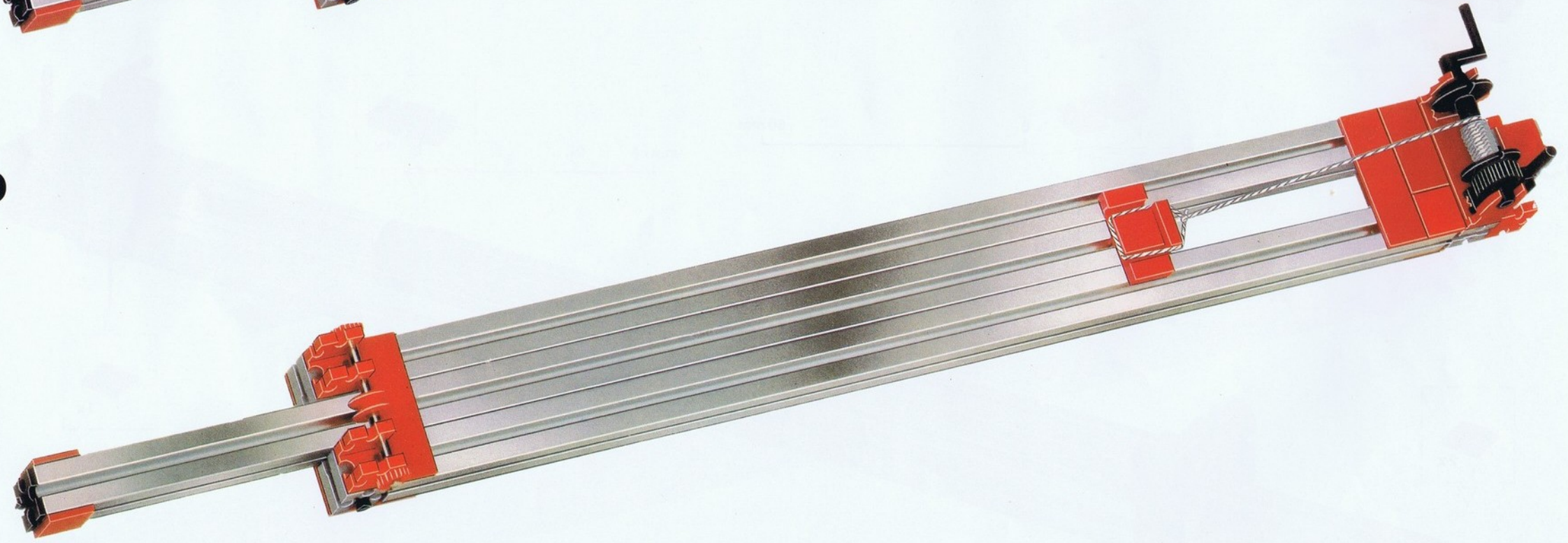

41

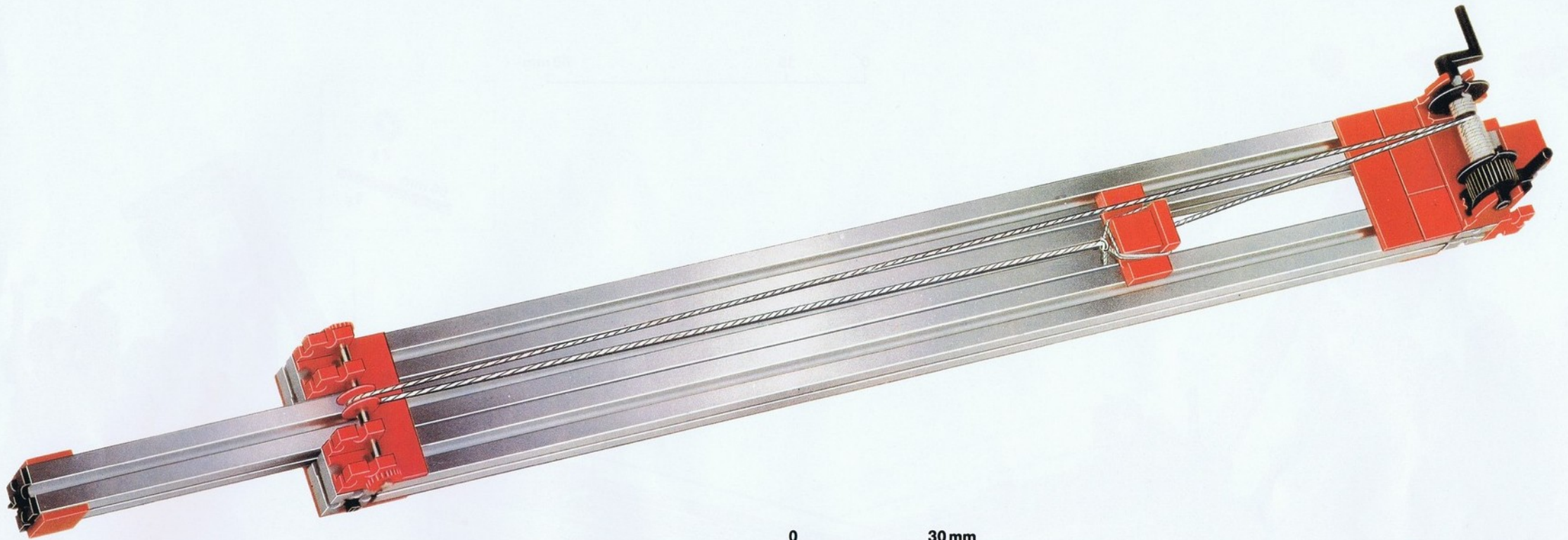

0 30 mm

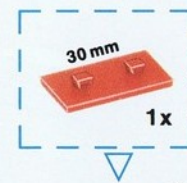

42

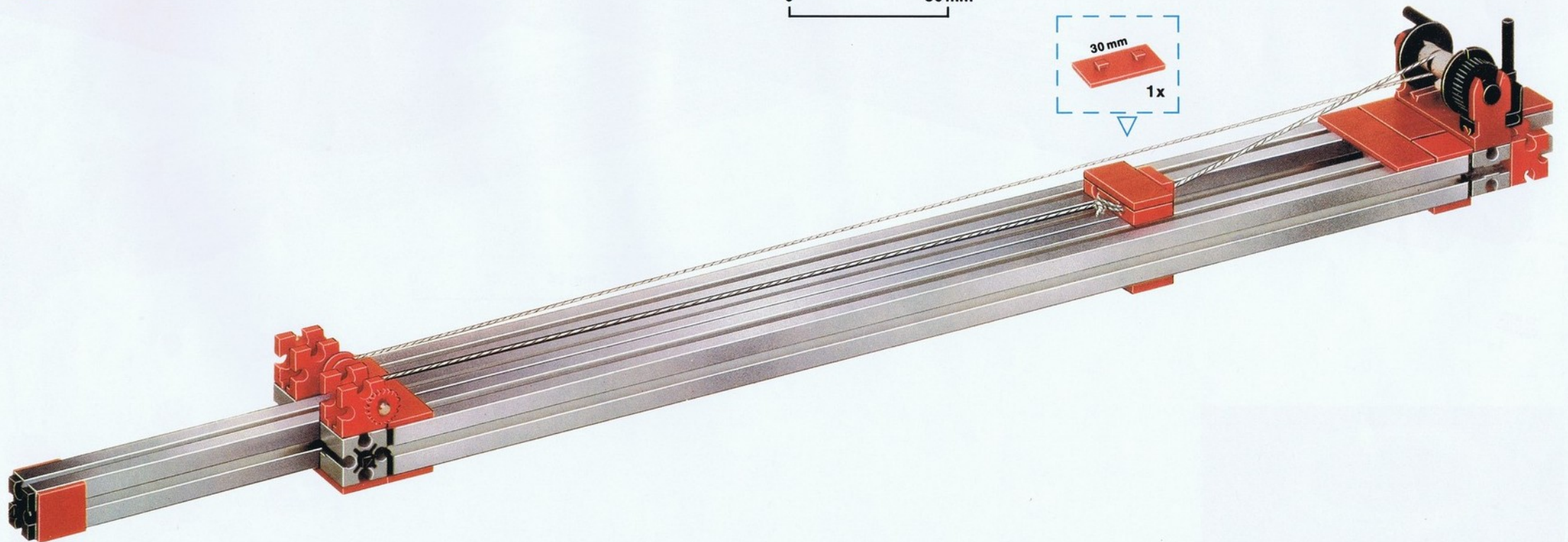

0 15 60 mm

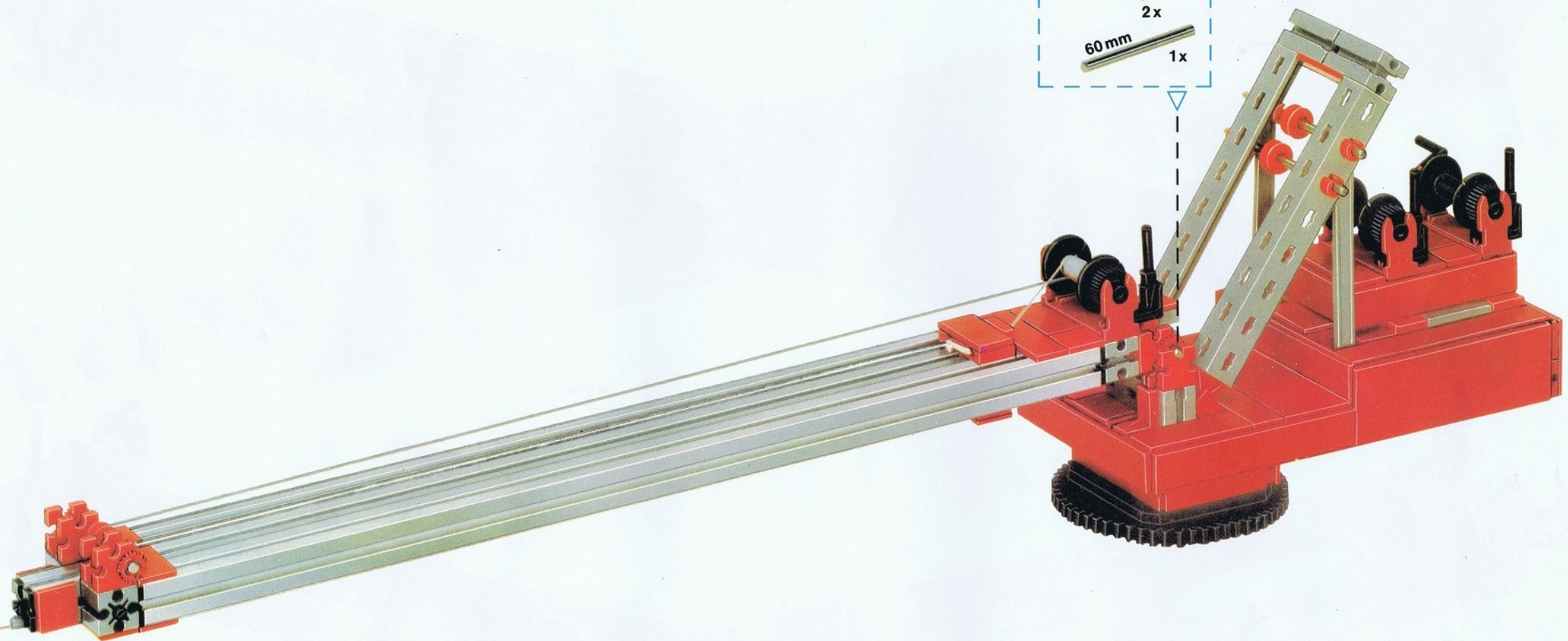
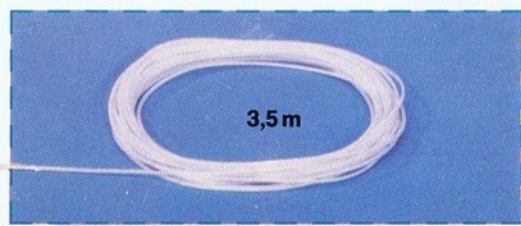

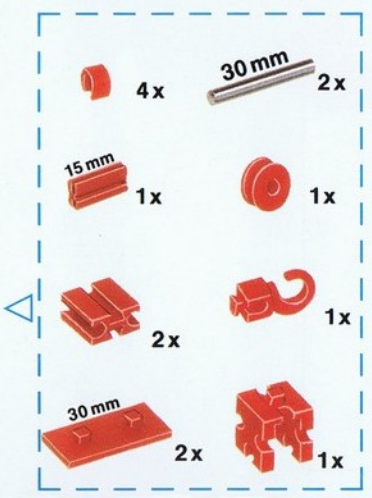
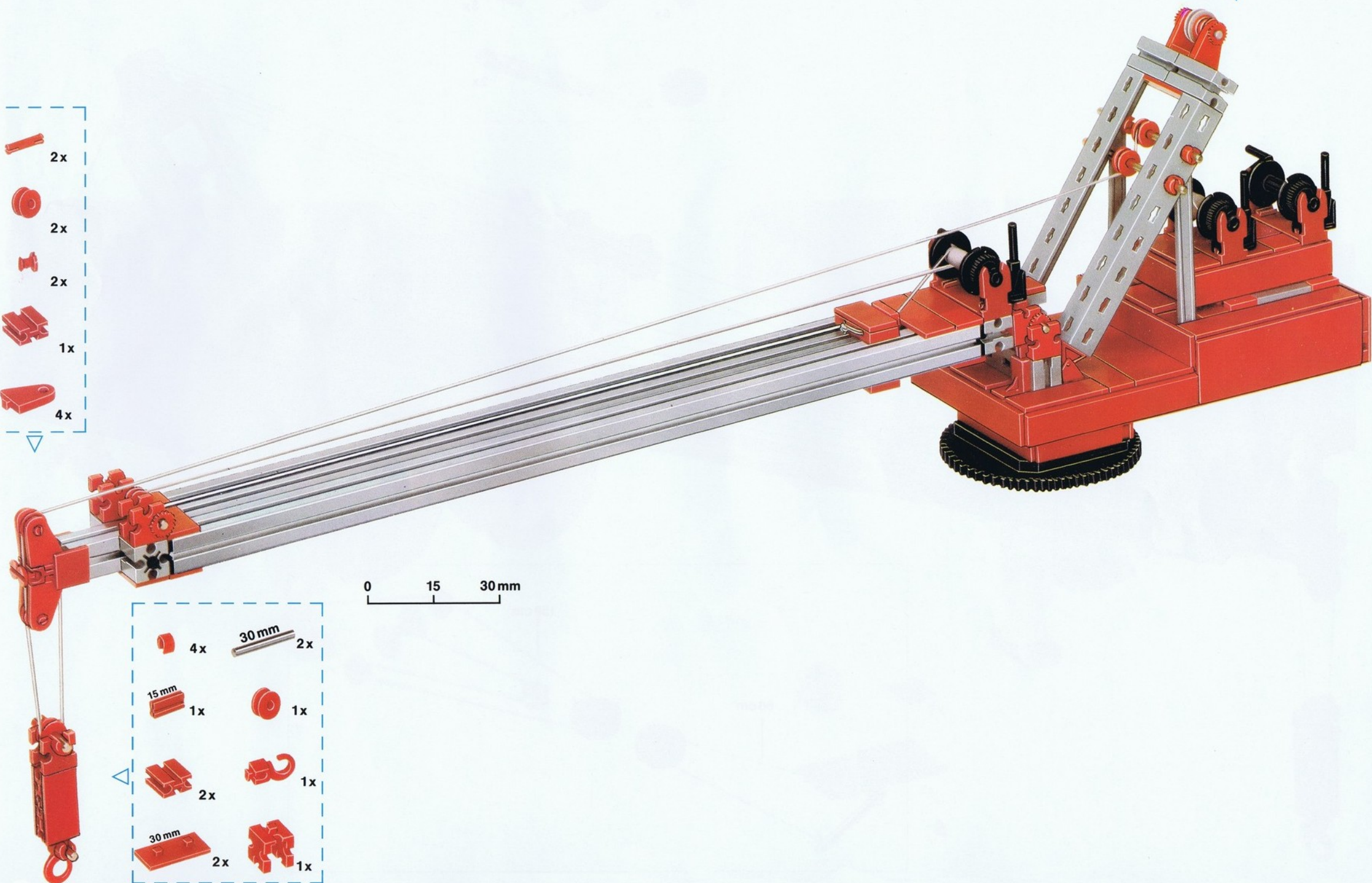
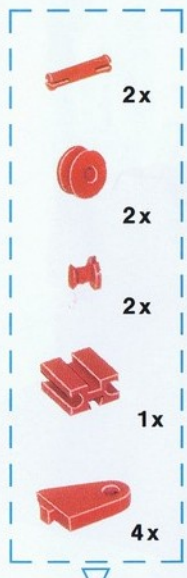
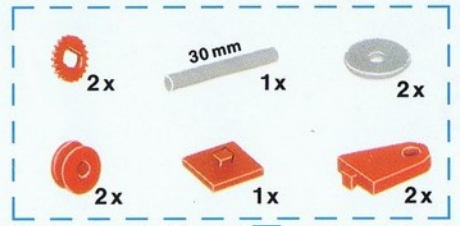

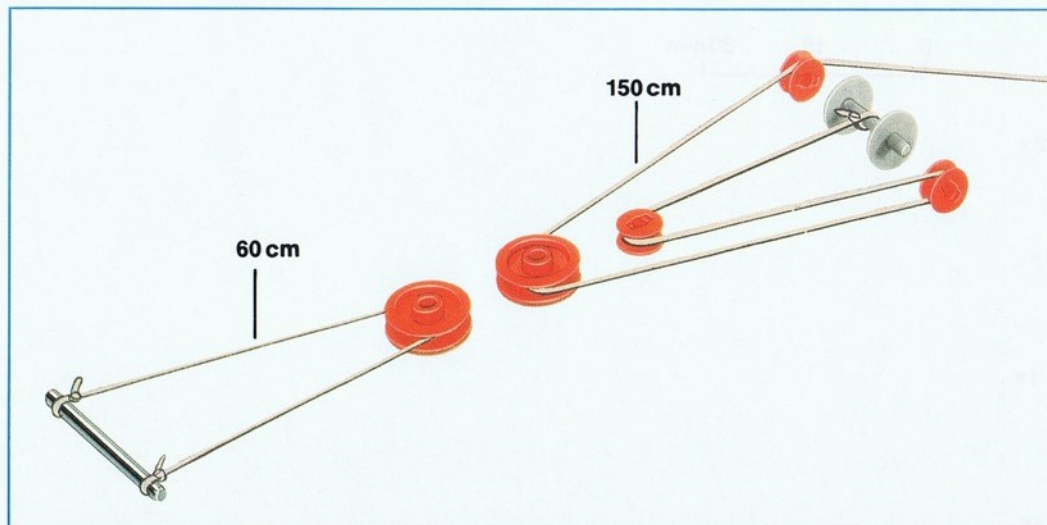
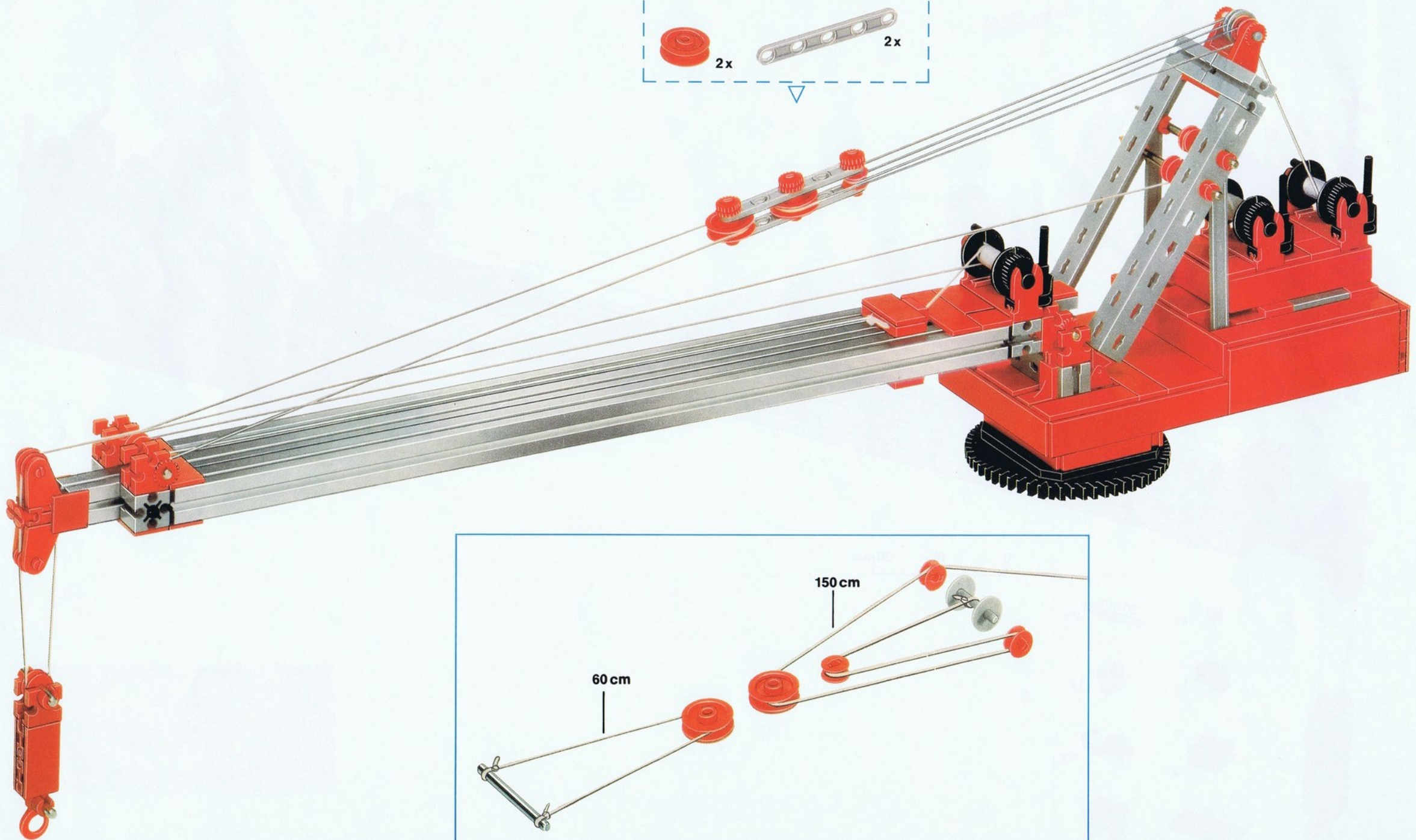
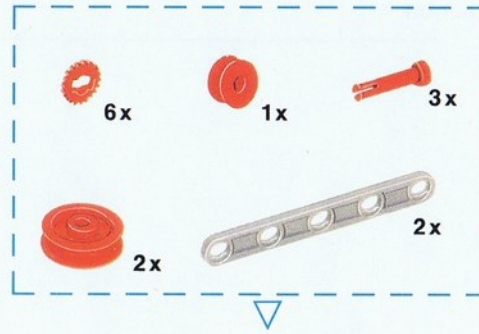

46

6A

47

8A

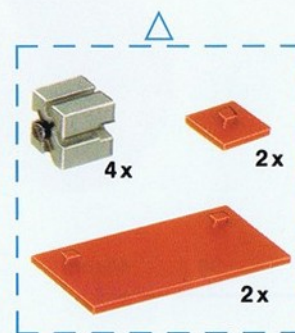
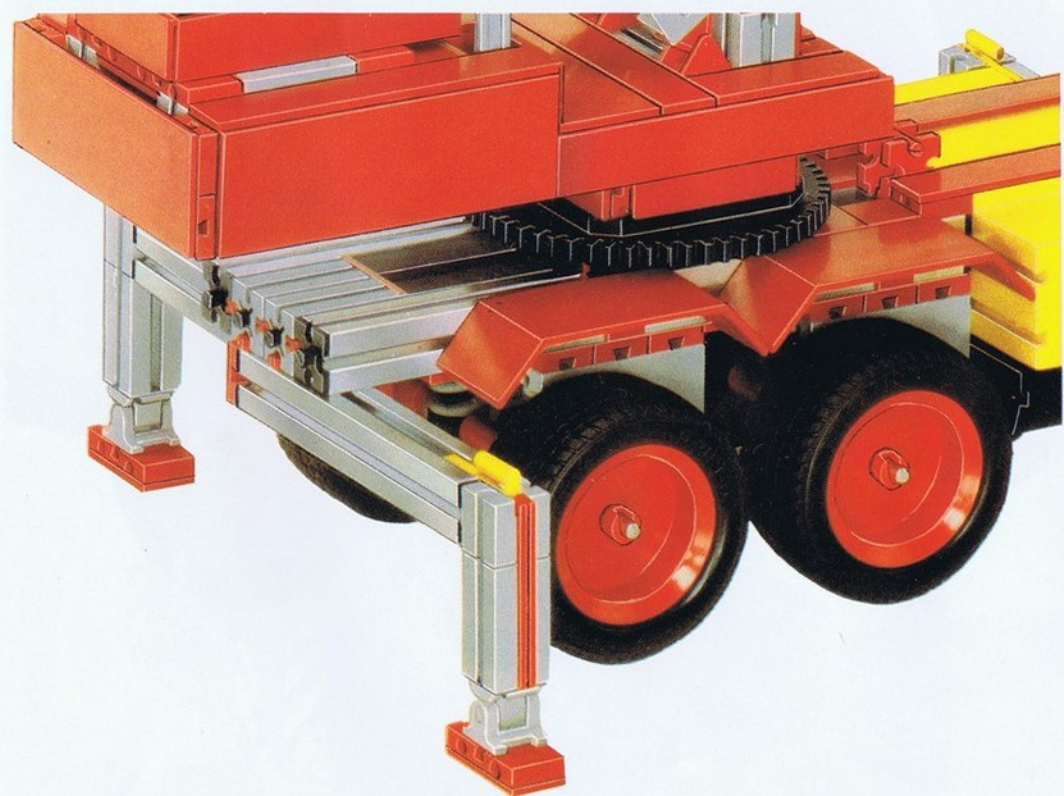

48

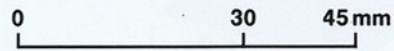
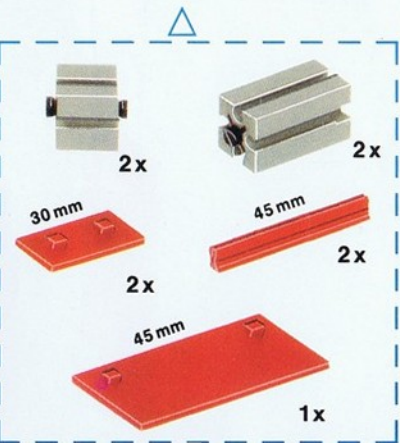
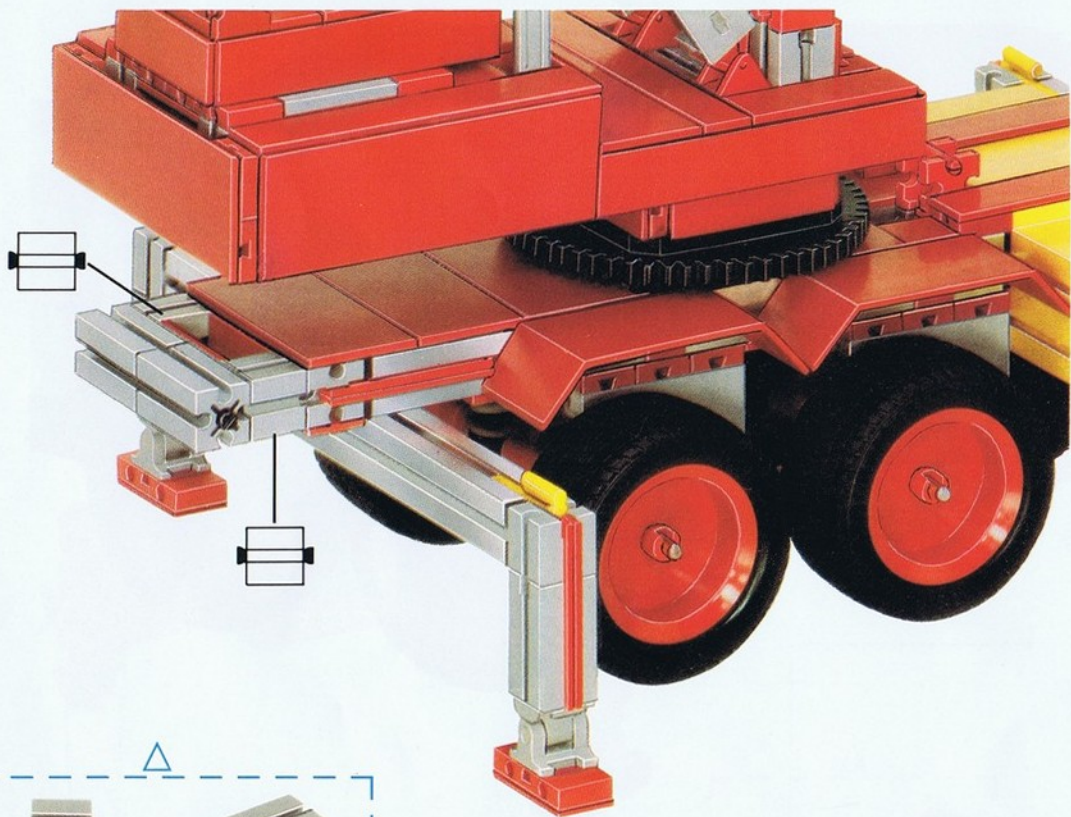

49

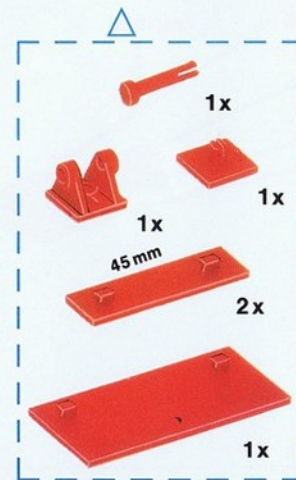
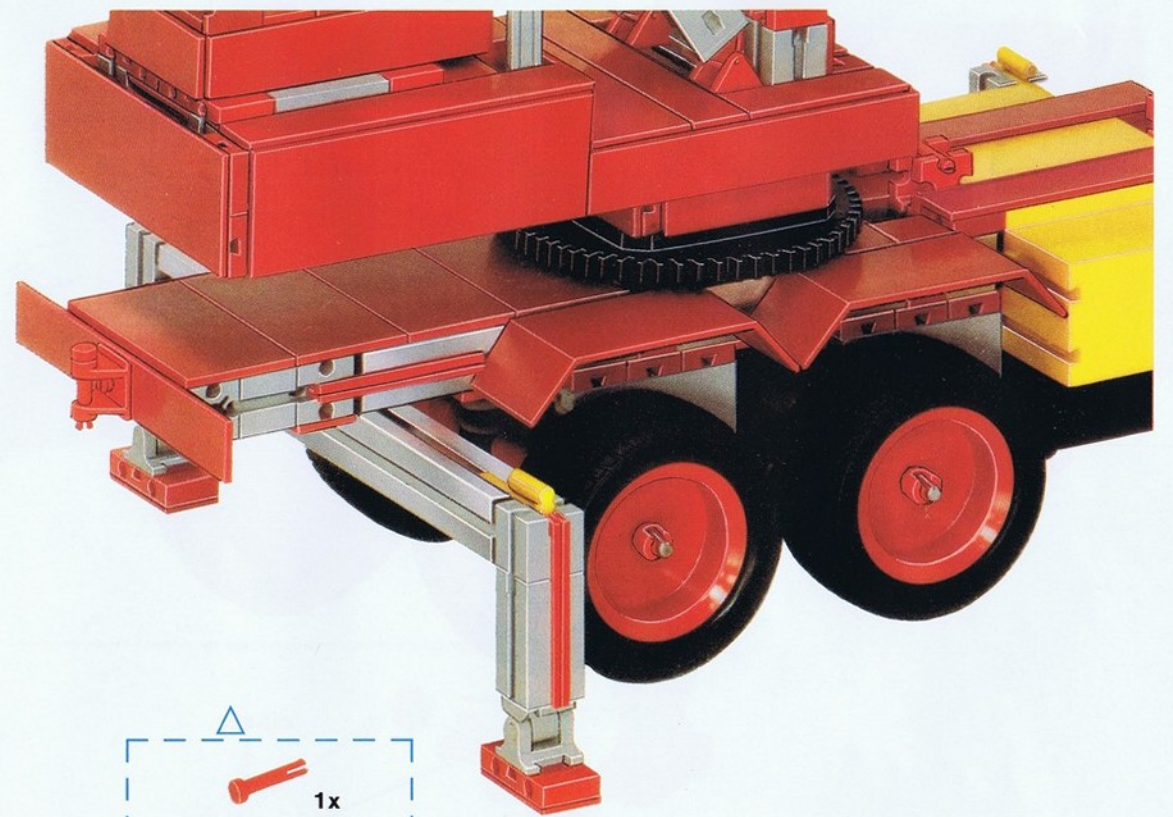





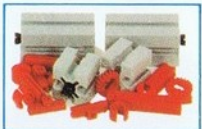

Ersatz- und Ausbauteile.  
Spare parts and detachable parts.  
Éléments de rechange et éléments de construction.  
Delen als reserve en voor uitbreiding.

Repuestos y accesorios.  
Pezzi di ricambio e di completamento.  
Reserv- och utbytesdelar.



Mit dem Fernlenk-Set/Radantrieb und Servo kann das Modell motorisiert werden. Der Radantrieb ist mit 3-Gang-Getriebe, Kardanwelle und Differential ausgerüstet. Das Servo lenkt das Fahrzeug in die gewünschte Fahrtrichtung.

Le modèle peut être motorisé grâce au poste de pilotage à distance/au pont et au servo. Le pont est équipé d'une boîte de 3 vitesses, d'un arbre de transmission et d'un différentiel. Le servo permet de diriger le véhicule dans la direction souhaitée.

Con el estuche de control remoto, rueda propulsora y el servo el modelo puede entrar en movimiento. La rueda propulsora está equipada con una caja de cambios de 3 velocidades, árbol de cardán y el diferencial. El servo dirige el vehículo en la dirección deseada.

Med fjärrstyrningssetet/hjuldrivningen och servon kan modellen motoriseras. Hjuldrivningen är utrustad med växellåda med tre hastigheter, kardanaxel och differential. Servon styr fordonet i önskad riktning.

The model may be motorized by means of the remote control set/wheel drive and servo facility. The wheel drive mechanism has been equipped with three-speed transmission, universal joint shaft and differential gearing. The servo facility steers the vehicle into the required direction.

Door middel van de set voor het besturen op afstand/wielaandrijving en servomechanisme kan het model gemotoriseerd worden. De wielaandrijving is met een versnelling met drie gangen, cardanas en differentieel uitgerust. Het servomechanisme stuurt de wagen in de gewenste richting.

Il modello può essere motorizzato con impianto di telecomando/motore alle ruote e servo. L'impianto motore è fornito di cambio a tre marce, albero cardanico e differenziale. Il servo dirige il veicolo nella direzione desiderata.

1

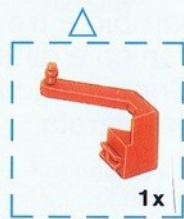
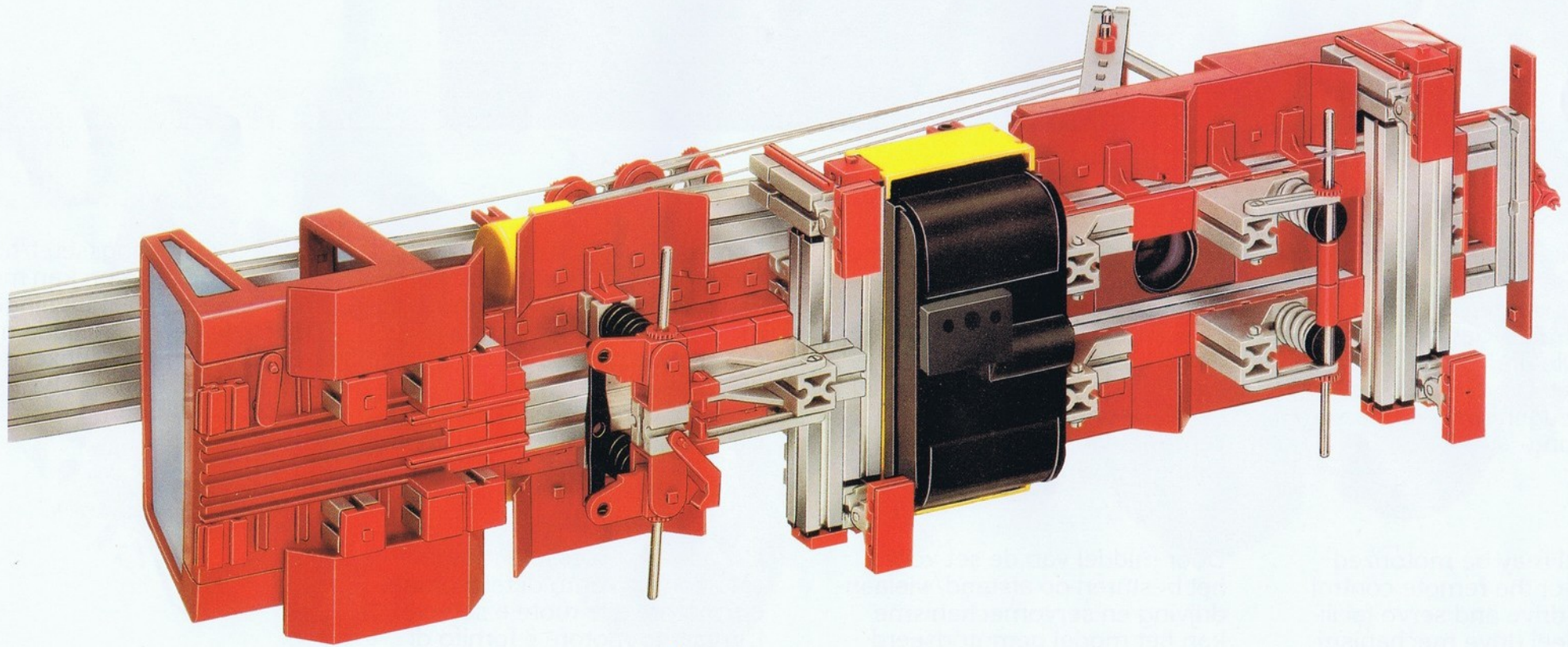
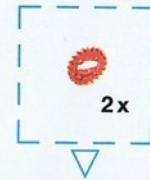

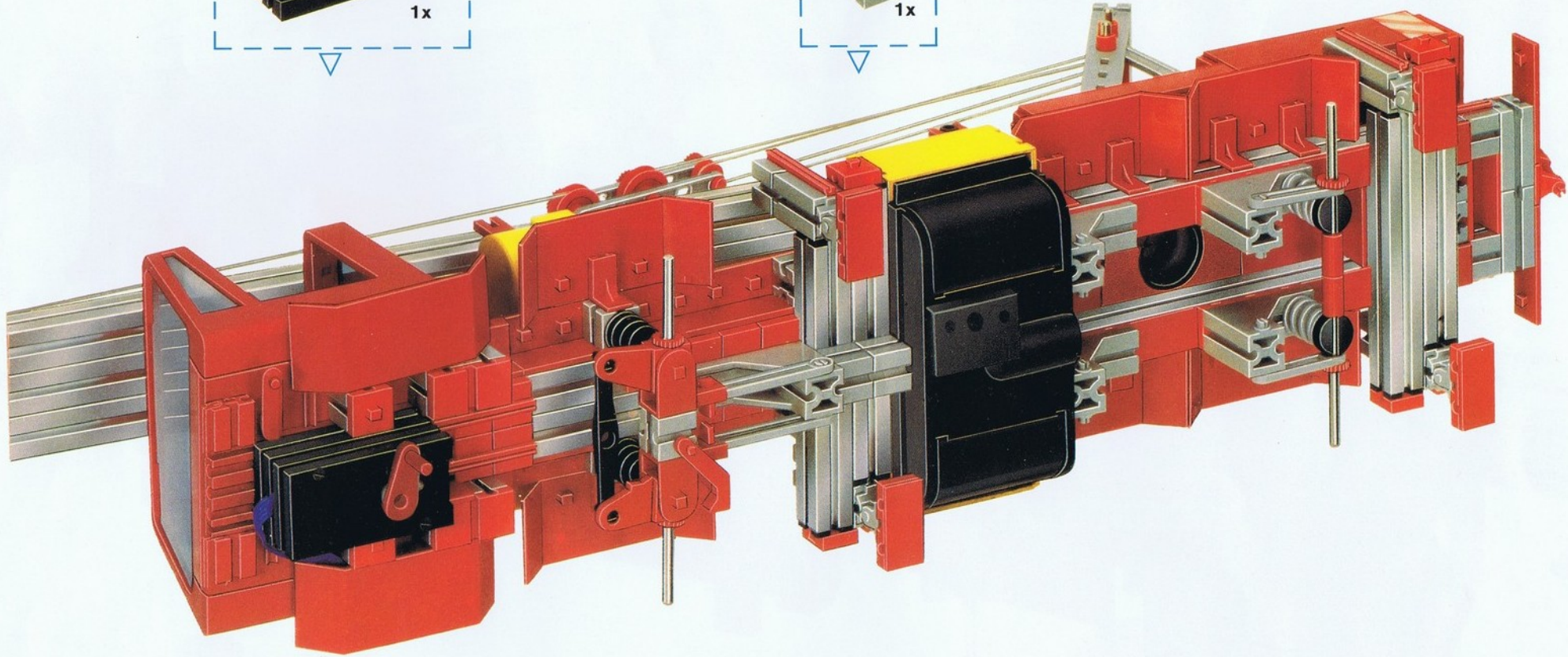
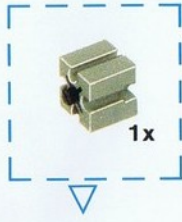
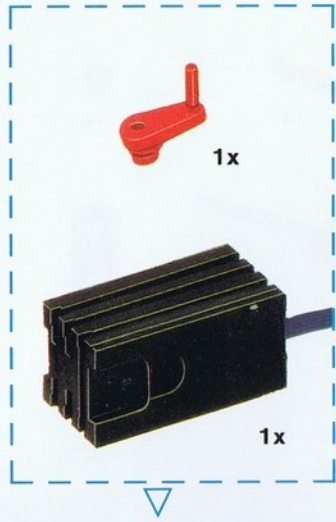

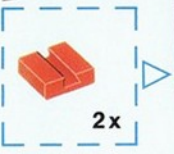
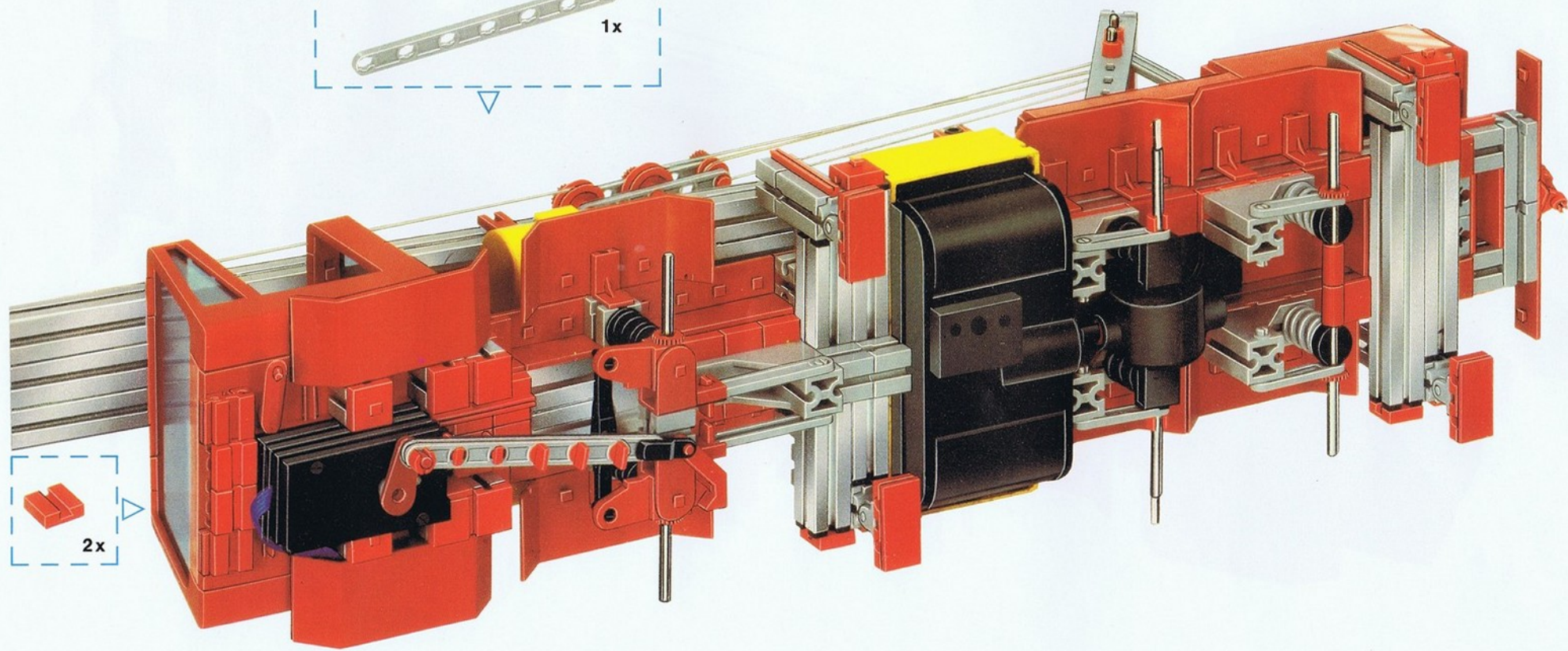
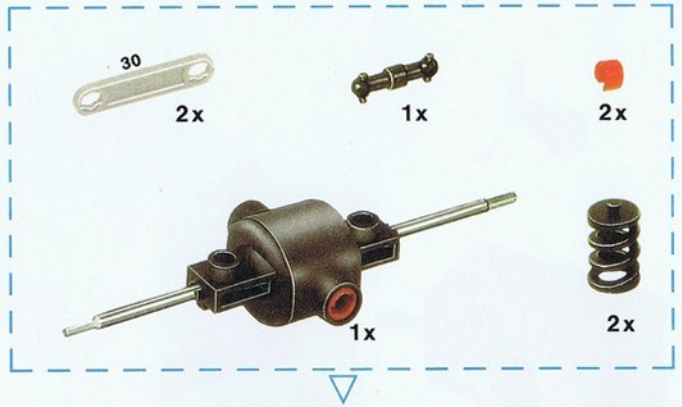
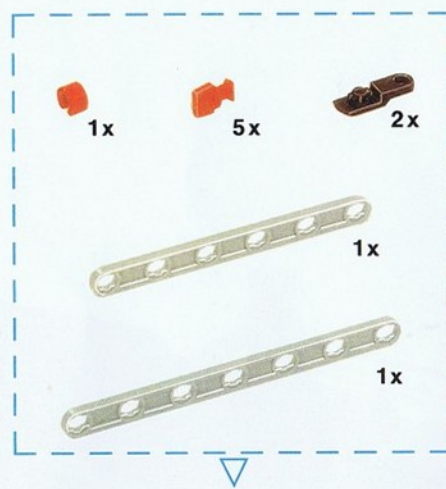



7x  
30 mm  
4x

2x 2x  
2x 2x

2x 2x  
2x 2x  
2x 2x

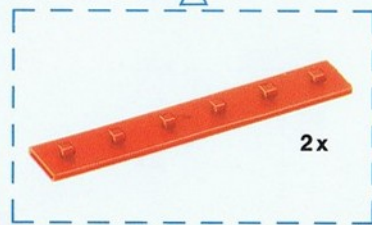
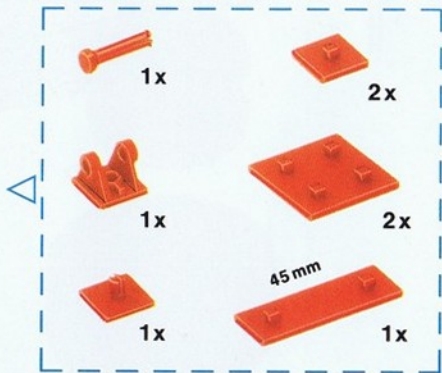
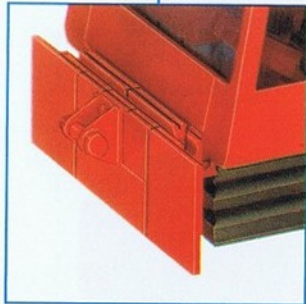

0 45 mm



6

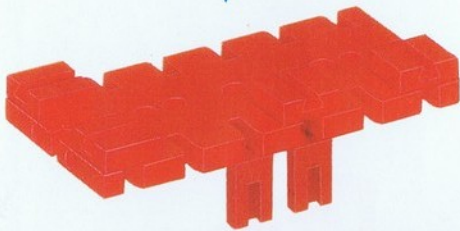
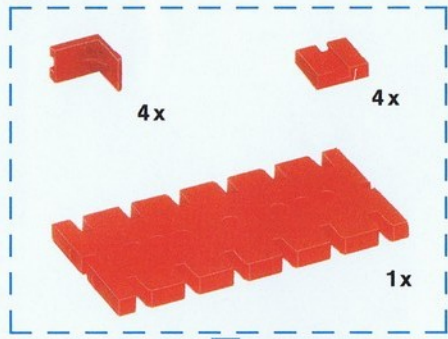

7

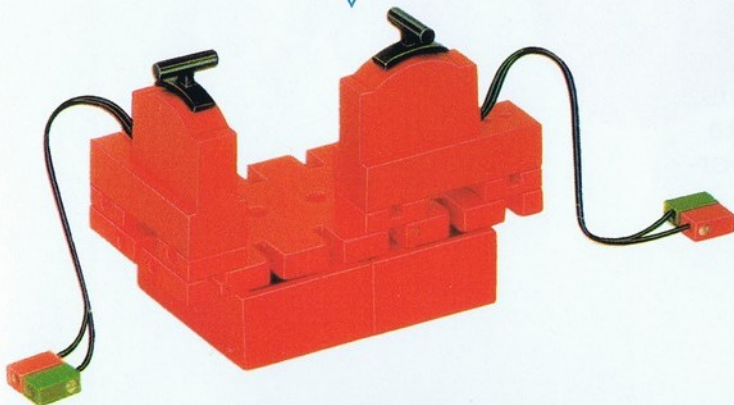
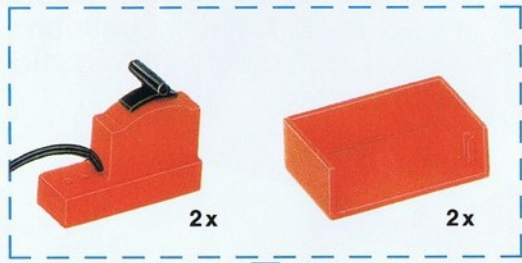

Steckerbuchse nur für Fernsteuerung

Socket for remote control only

Fiches femelles seulement pour la télécommande

Stekkerbus uitsluitend voor afstandbesturing

Borne de enchufe solo para control a distancia

Presse solo per comando a distanza

Kontakturtag för fjärrstyrning

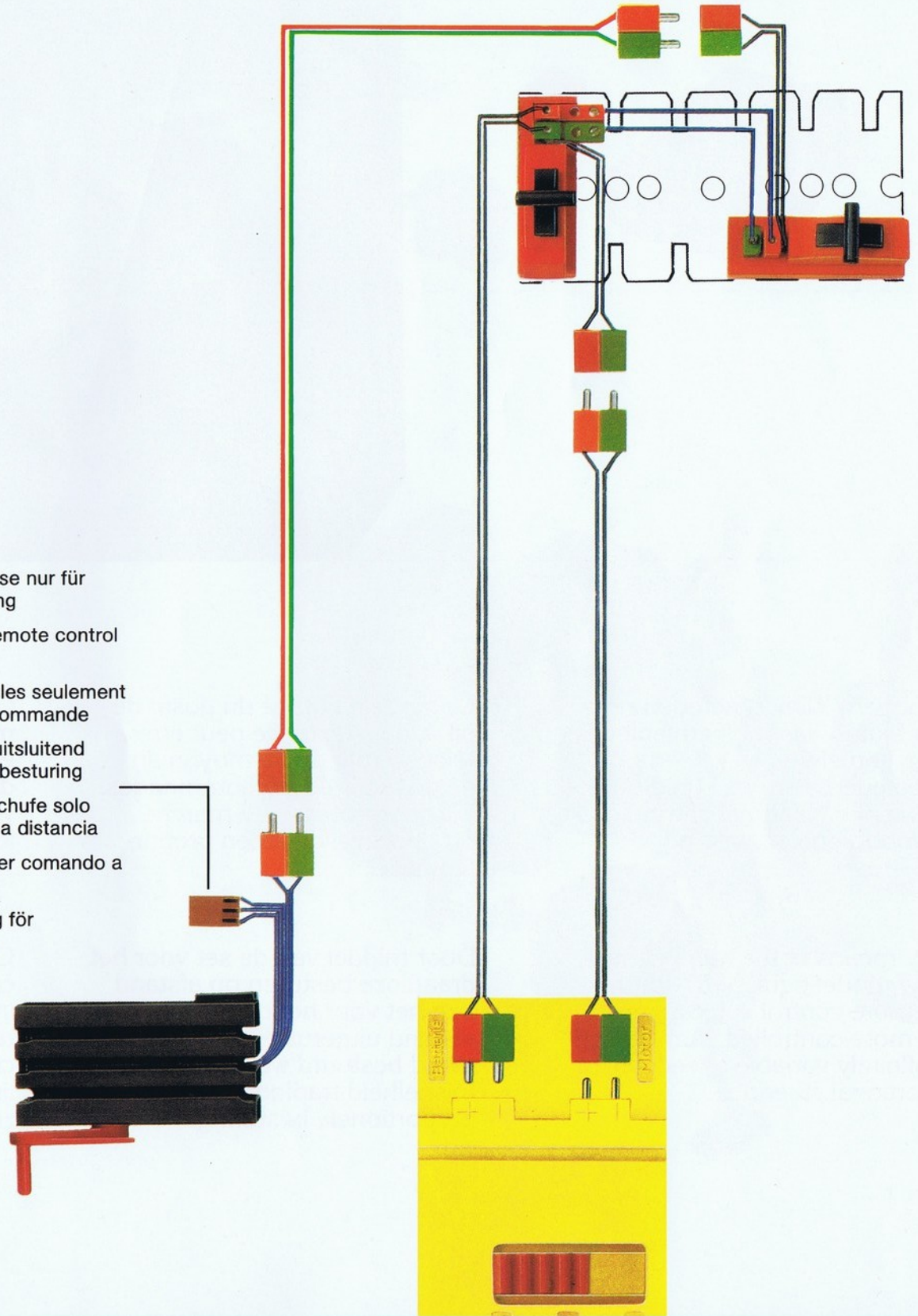



Mit dem Funkfernsteuerungs-Set kann das mit Fernlenk-Set ausgerüstete Modell ferngesteuert werden. Funktion: stufenlose Fahrgeschwindigkeit, proportionale Lenkung.

Le modèle équipé du poste de pilotage à distance peut être télécommandé au moyen du poste radio de télécommandes. Fonction: vitesse de marche progressive, direction proportionnelle.

Con el estuche de radiotelemando, el modelo equipado con el control remoto puede ser dirigido a distancia. Función: velocidad de marcha sin escalones, dirección proporcional.

Med radiofjärrstyrningssetet kan den med fjärrstyrning utrustade modellen fjärrstyras. Funktion: steglös körhastighet, proportionell styrning.

By means of the radio control, the model equipped with the remote control set, can be remote-controlled. Function: infinitely variable speed, proportional steering.

Door middel van de set voor het draadloze besturen op afstand kan het voor het bedienen op afstand uitgeruste model op afstand bestuurd worden. Functie: Rijsnelheid traploos regelbaar, proportionele besturing.

Con l'impianto di radiotelecomando il modello fornito di impianto di teleguida può essere telecomandato. Funzione: velocità di marcia variabile senza limiti, comando sterzo proporzionale.

1



2

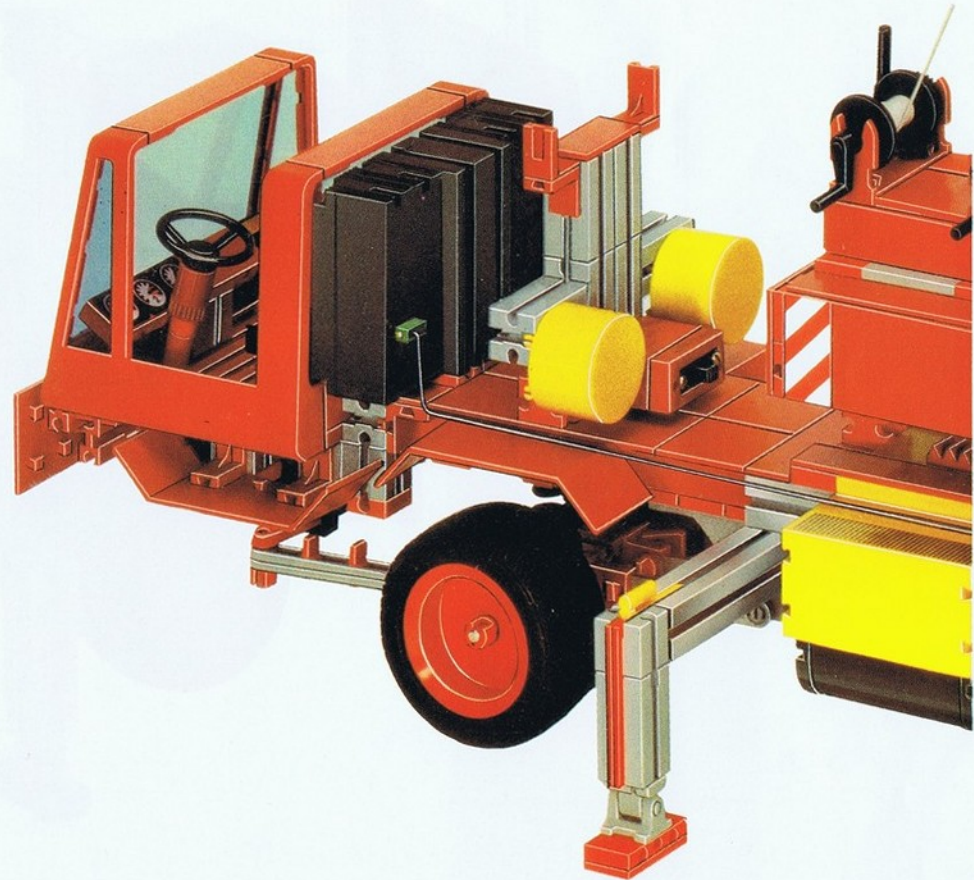
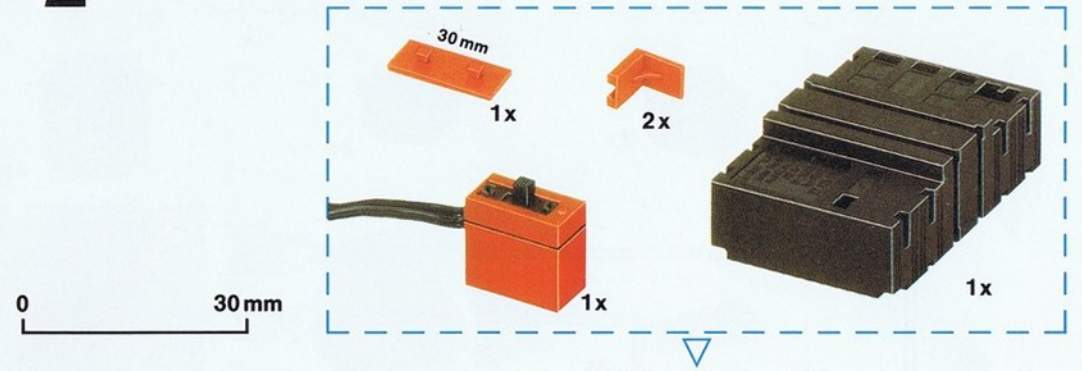

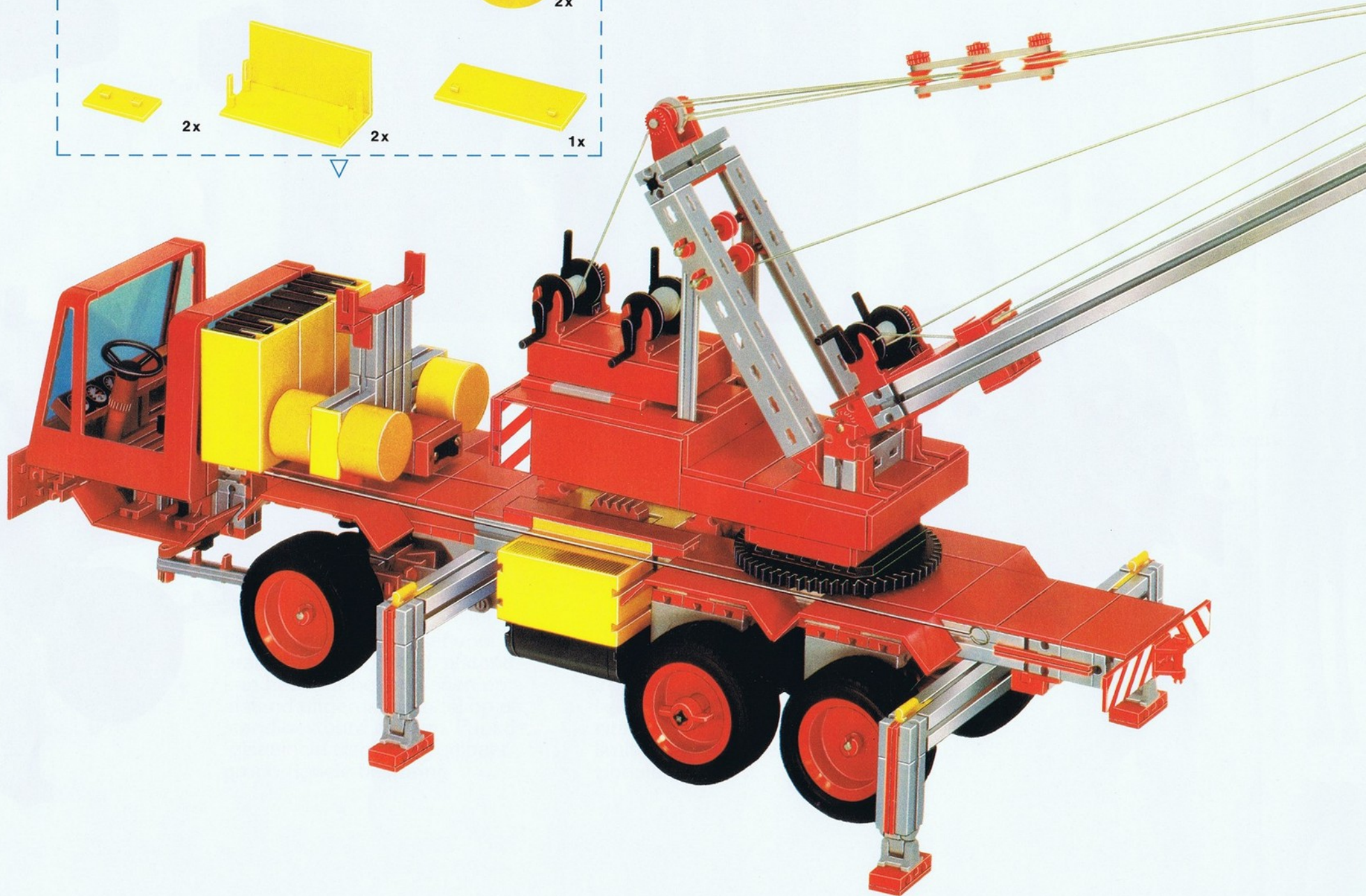
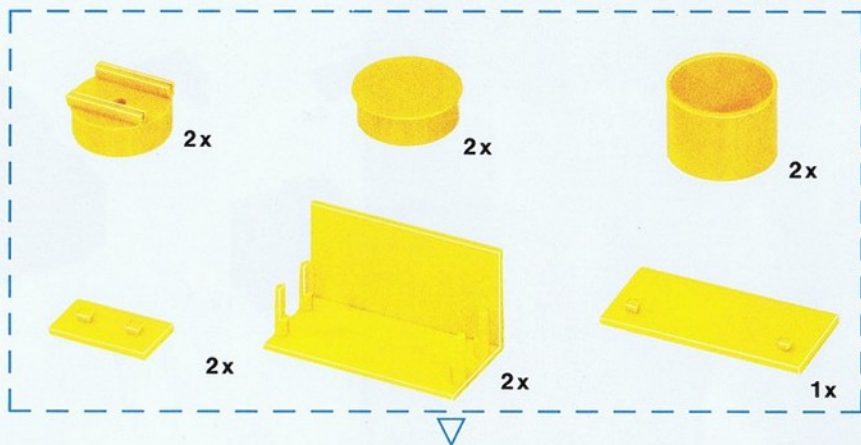

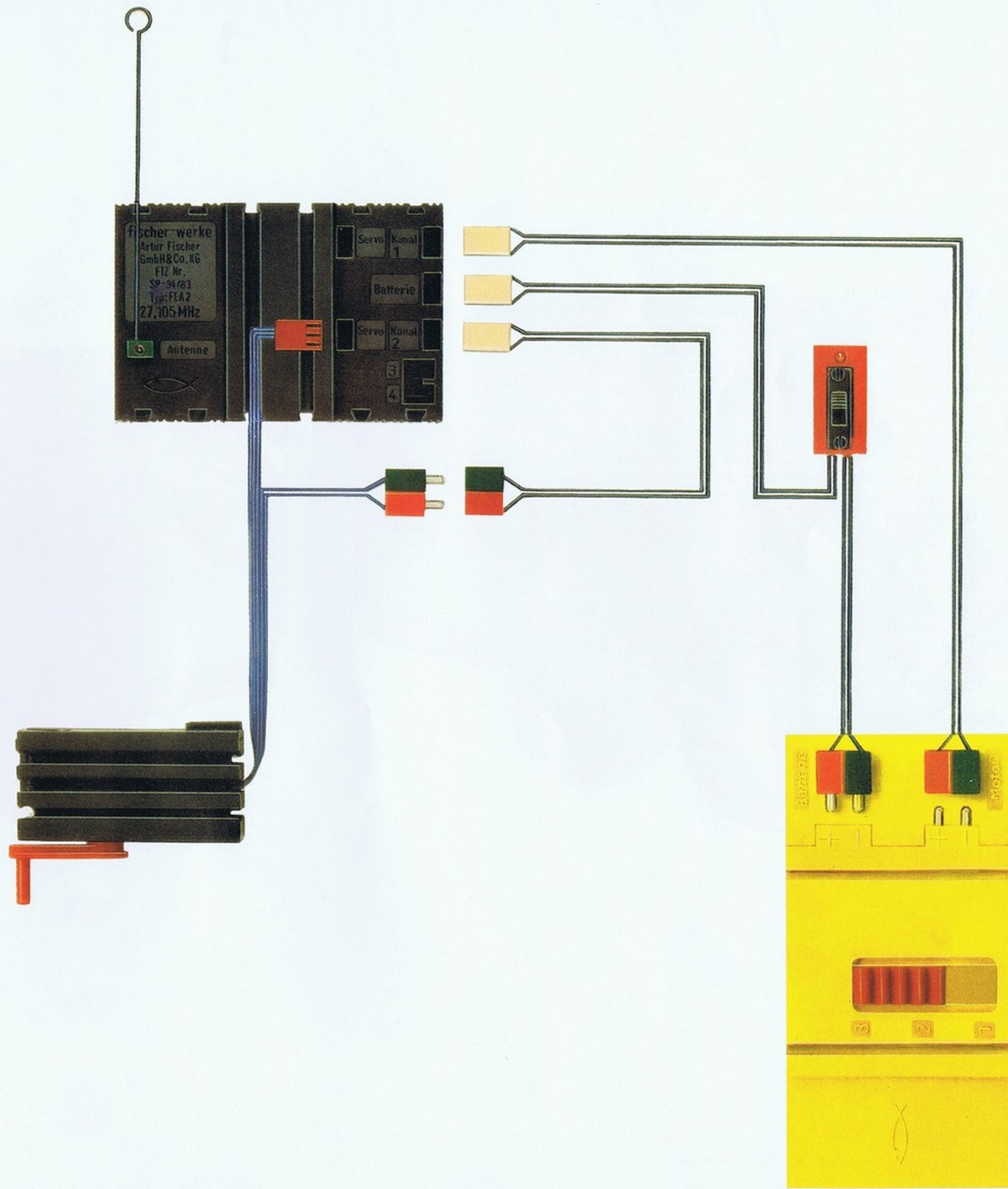

Der Drehkranz ist motorisierbar mit Minimotor + Getriebe (mini-mot 1) oder Minimotor (mini-mot 10). Der motorisierte Drehkranz ist fernsteuerbar mit Empfänger-Kanal 3/4.

The live ring can be motorized by means of minimotor and gearing (mini-mot 1) or minimotor (mini-mot 10). The motorized live ring is remote-controllable by means of receiver channel 3/4.

La couronne de rotation est motorisable grâce au minimoteur et à la boîte de vitesses (mini-mot 1) ou minimoteur (mini-mot 10). La couronne de rotation est télécommandable grâce au canal récepteur 3/4.

De zwenktandkrans kan door middel van de minimotor + transmissie (mini-mot 1) of de minimotor (mini-mot 10) gemotoriseerd worden. De gemotoriseerde zwenktandkrans kan met behulp van het ontvangerkanaal 3/4 op afstand bediend worden.

La corona giratoria se puede motorizar con el minimotor + caja de cambios (mini-mot 1) o minimotor (mini-mot 10). La corona motorizada se puede dirigir a distancia con el canal receptor 3/4.

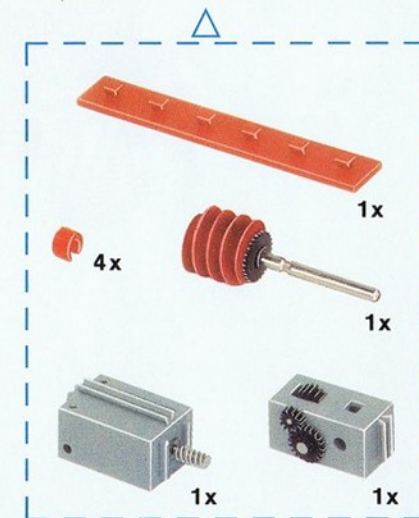
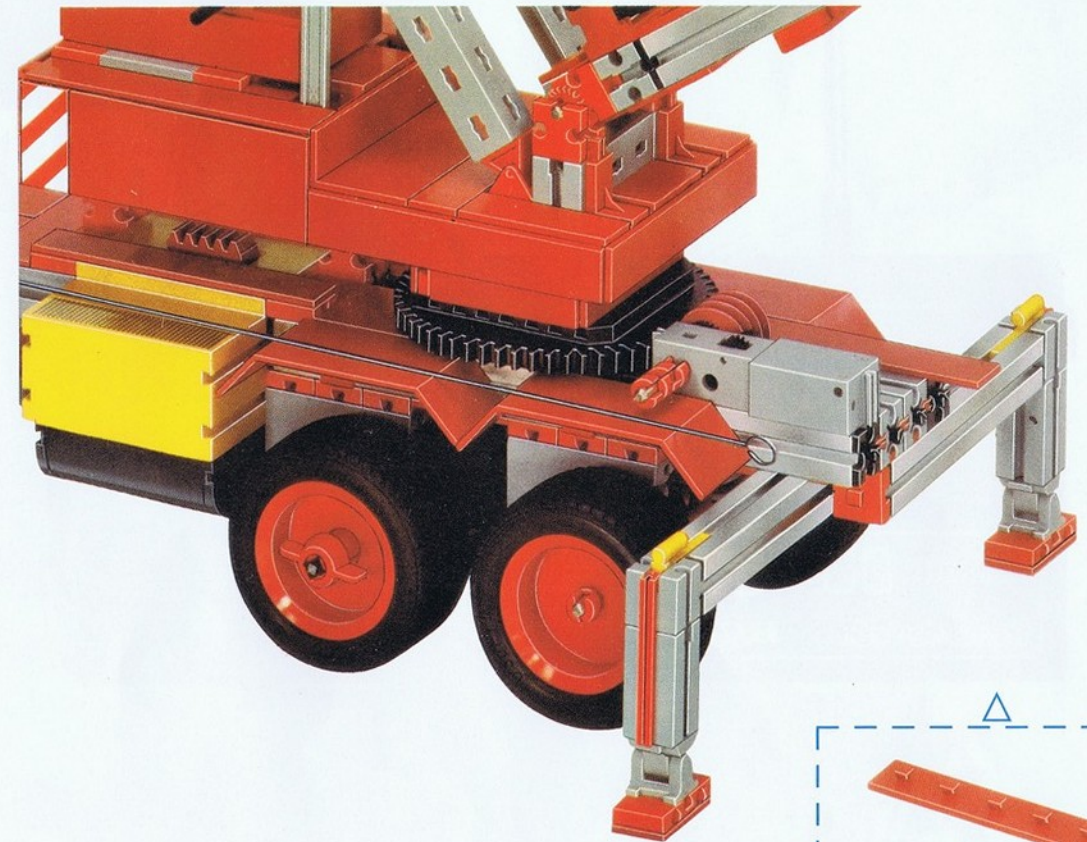

La corona girevole è motorizzabile con minimotore + cambio (minimotore 1) o minimotore (minimotore 10). La corona girevole motorizzata è telecomandabile con il canale ricevente 3/4.

Svängkransen kan motoriseras med minimotor + växel (mini-mot 1) eller minimotor (minimot 10). Den motoriserade svängkransen kan fjärrstyras med mottagarkanal 3/4.



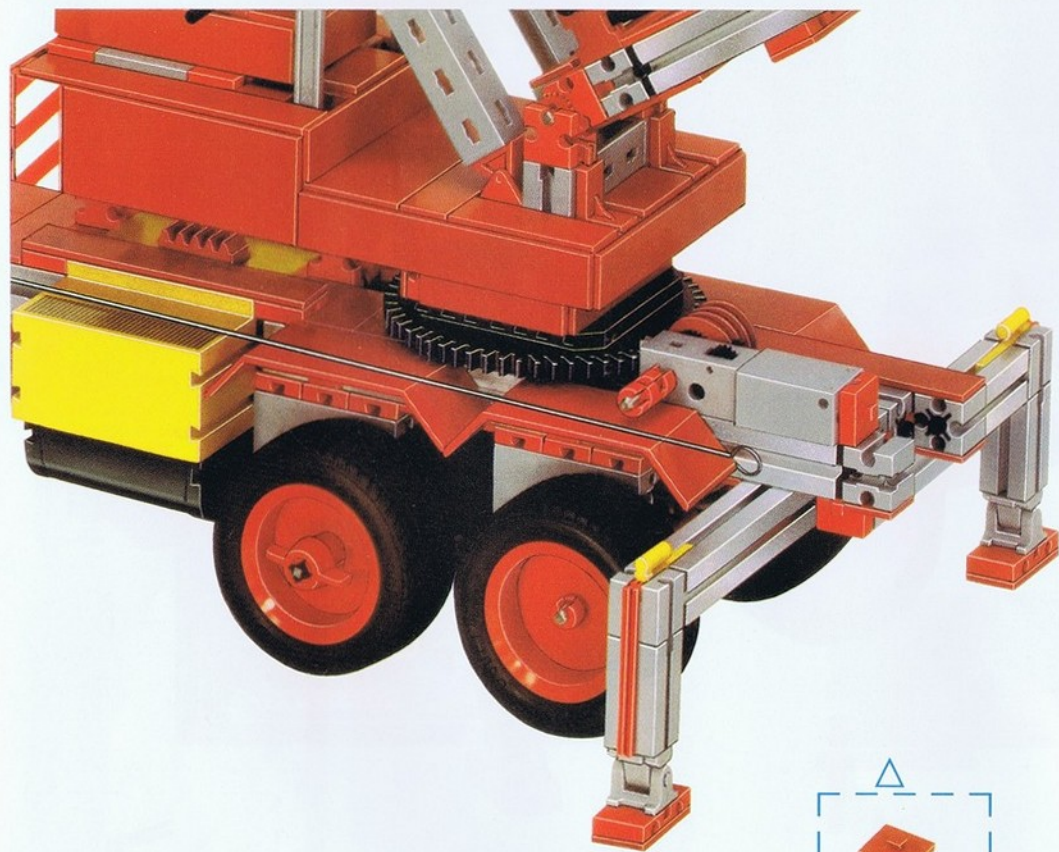



2

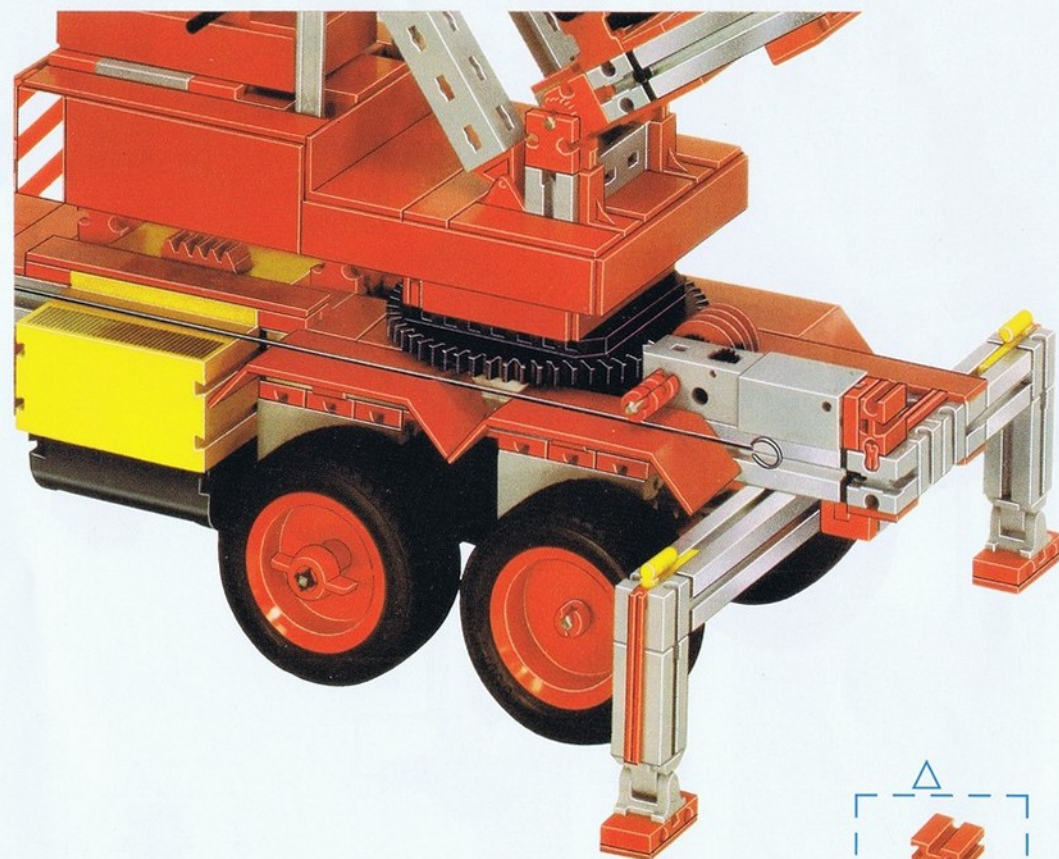

-  2x
-  1x
-  2x

3







-  1x
-  2x
-  45mm 1x

0 45mm

4





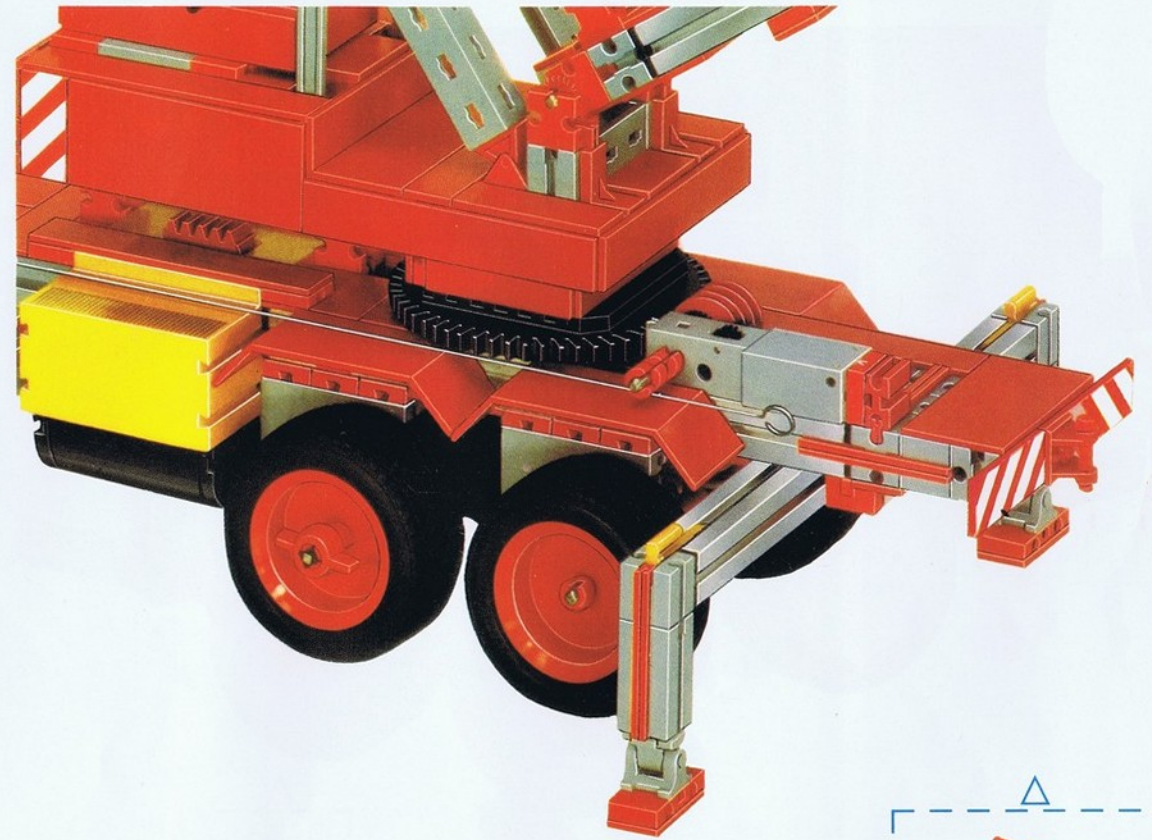

-  2x
-  2x
- 30 mm
-  2x
- 45 mm
-  2x

0 30 45 mm

5



-  1x
-  1x
-  1x
- 45 mm
-  2x
-  1x



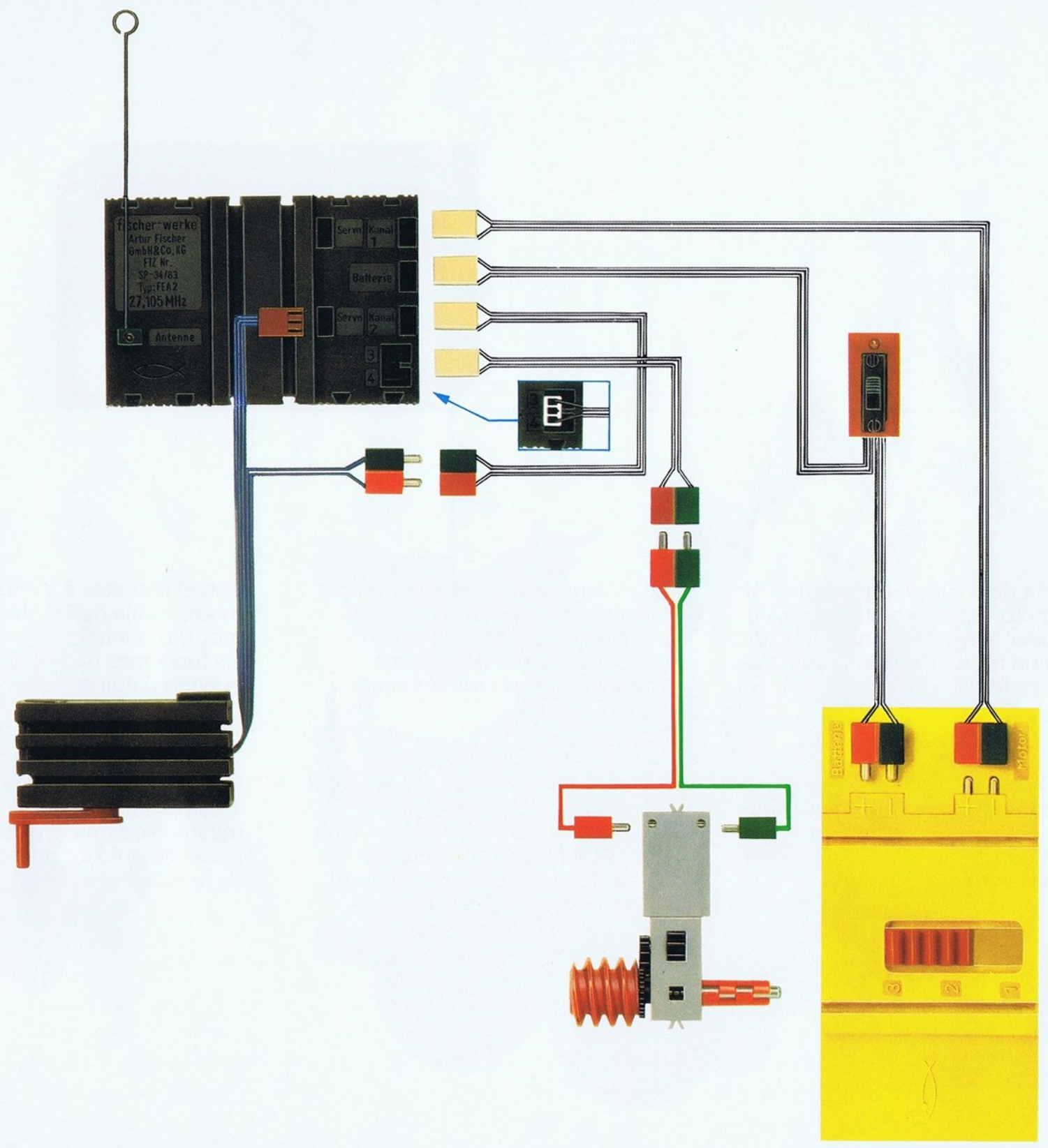



Mit dem Empfänger 2 und Mini-motor + Getriebe (mini-mot 1) oder Minimotor (mini-mot 10) sind motorisierte Kranfunktionen fernsteuerbar.

Les fonctions de la grue motorisée sont télécommandables grâce au récepteur 2 et au mini-moteur + boîte de vitesses (mini-mot 1) ou minimoteur (mini-mot 10).

Con el receptor 2 y el mini-motor + caja de cambios (mini-mot 1) o minimotor (minimot 10) las funciones de la grua se pueden dirigir a distancia.

Med mottagaren 2 och mini-motor + växel (minimot 1) eller minimotor (minimot 10) kan motoriserade kranfunktioner fjärrstyras.

By means of the receiver 2 and minimotor + gearing (mini-mot 1) or minimotor (mini-mot 10), motorized crane functions are remote-controllable.

Door middel van de ontvanger 2 en minimotor + transmissie (mini-mot 1) of minimotor (mini-mot 10) kunnen de gemotoriseerde kraanfunkties bestuurd worden.

Con la ricevente 2 e minimotore + cambio (minimotore 1) oppure minimotore (minimotore 10) è possibile guidare per telecomando le funzioni della grua.

1



2

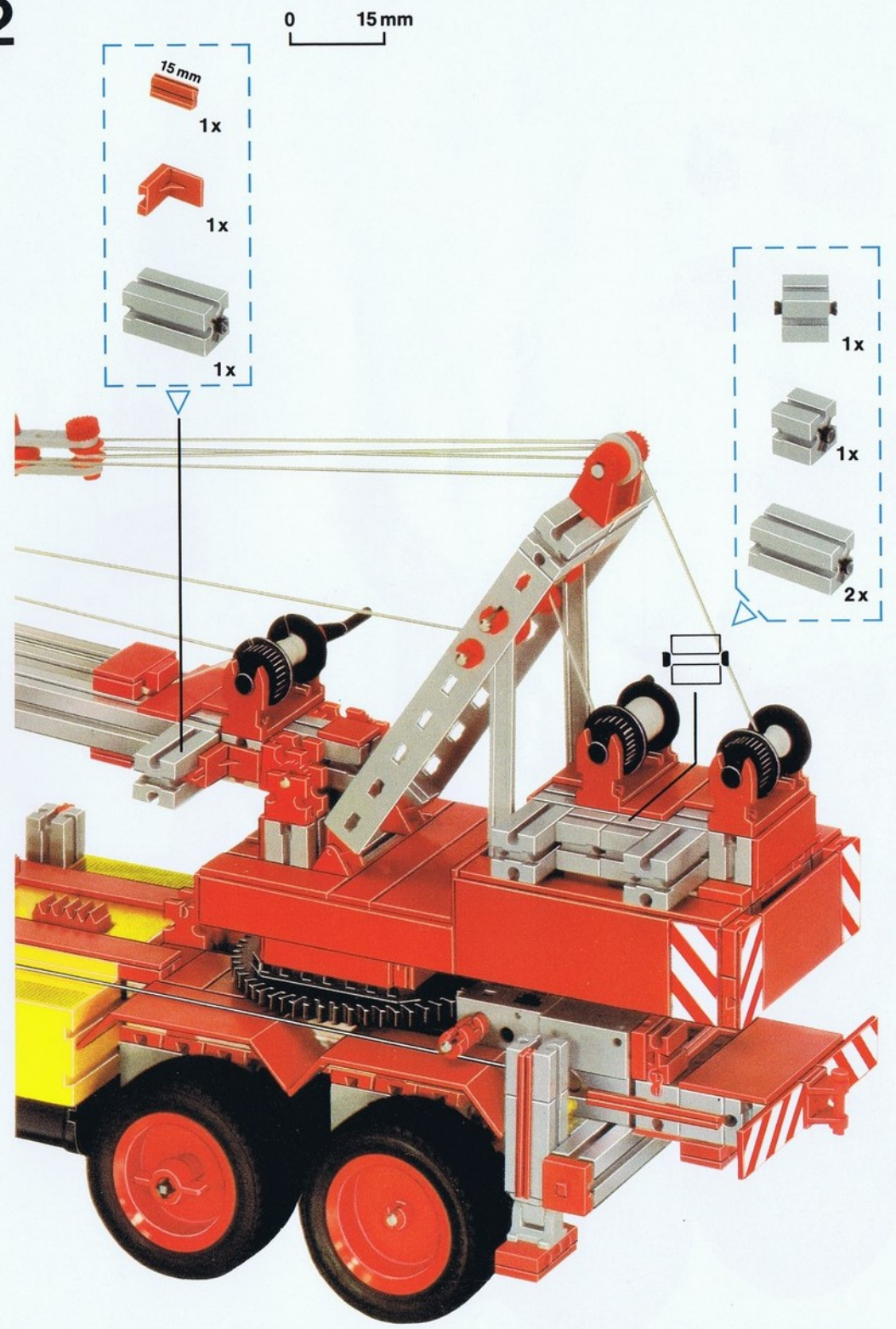

3

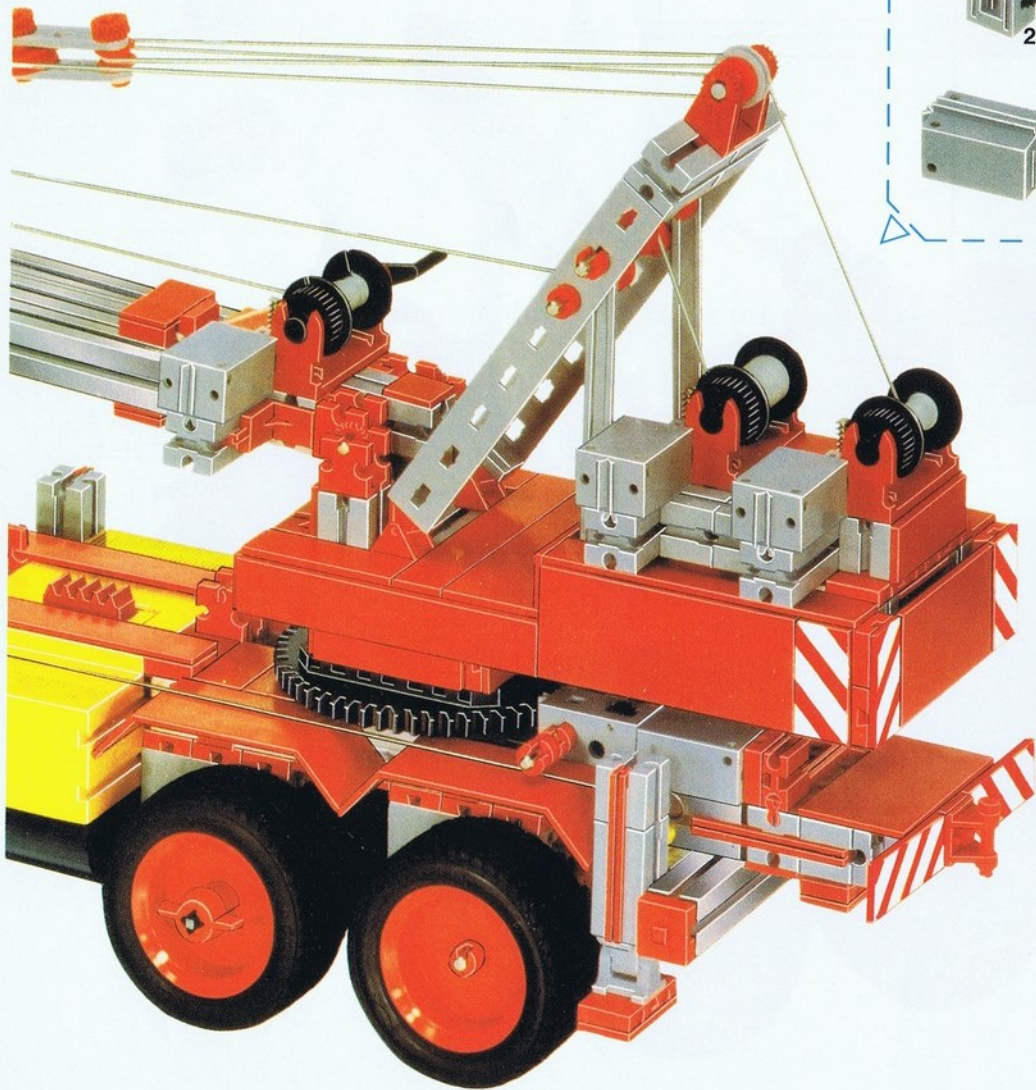
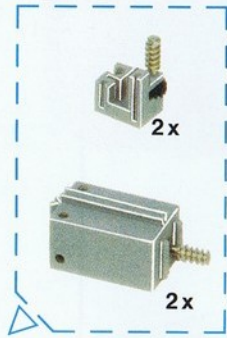
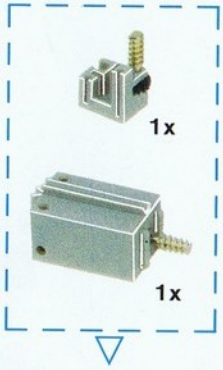

4

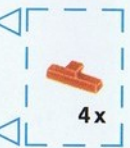
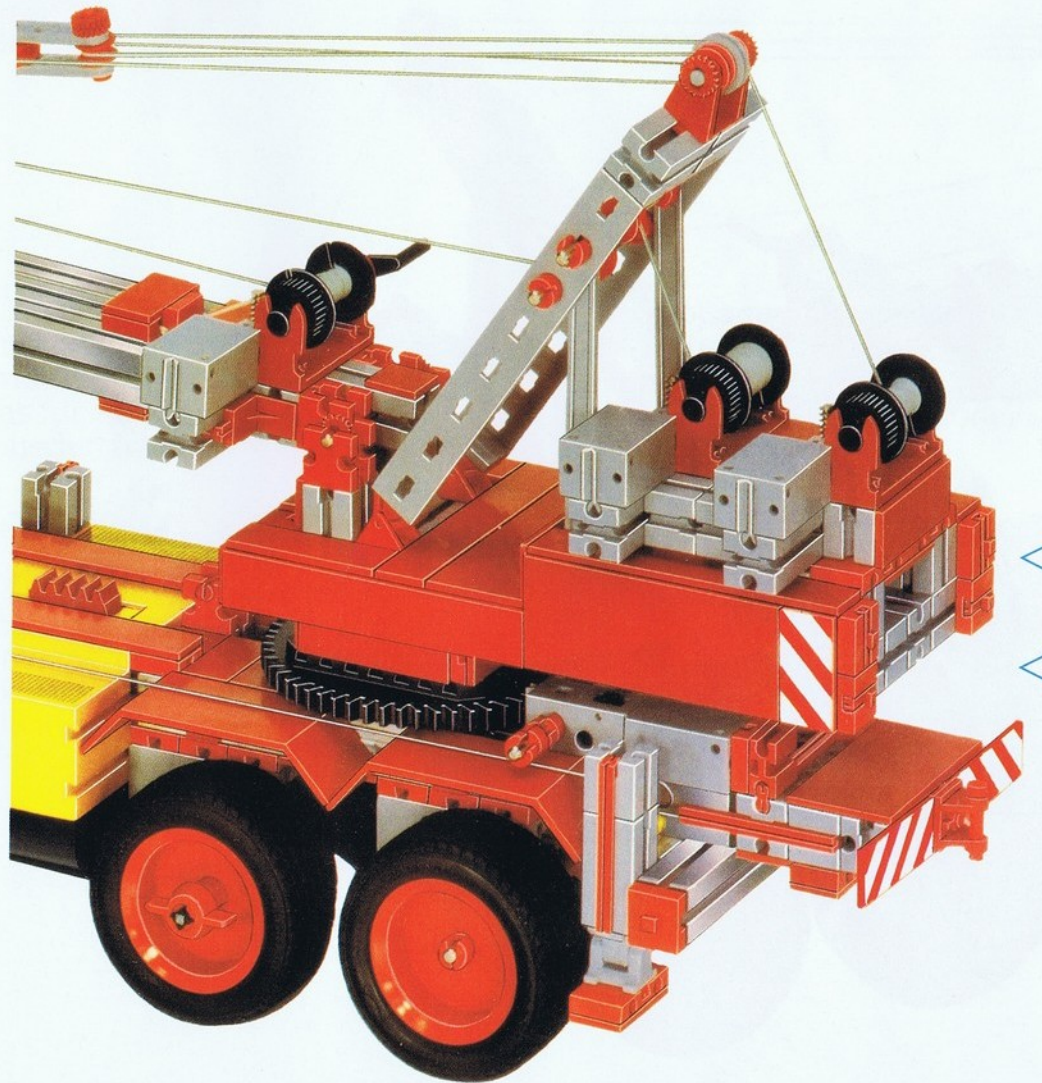

5

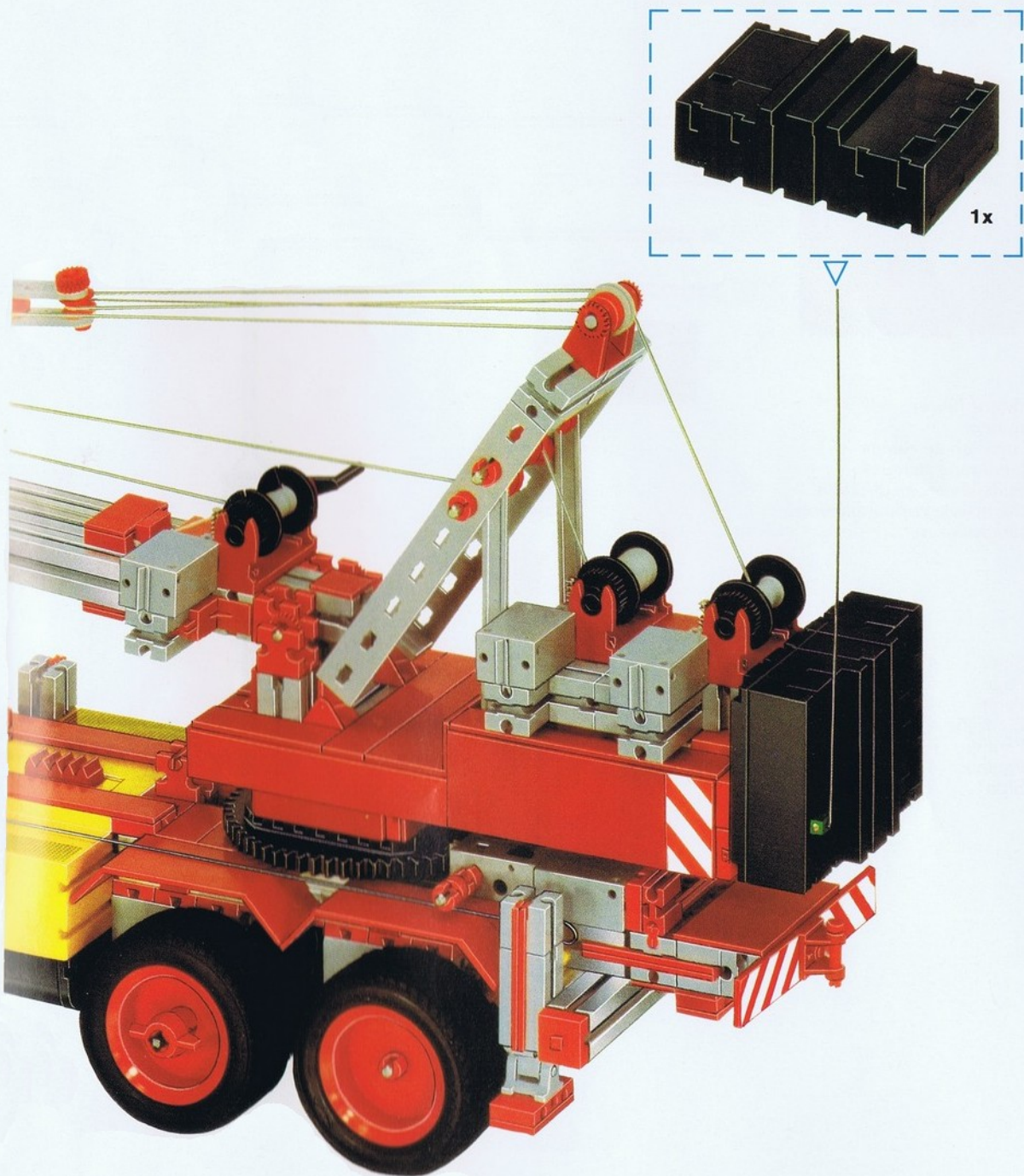

6

