



**fischertechnik** 

Begleitheft  
Activity booklet  
Manuel d'accompagnement  
Begeleidend boekje  
Cuaderno adjunto  
Folheto  
Libretto di istruzioni  
Сопроводительная инструкция  
随附说明书



*da Vinci*  
**MACHINES**  
10 MODELS



<b>The Superstar</b>	<b>p. 16</b>
<b>The Multitalent</b>	<b>p. 17</b>
<b>Mechanical Wings</b>	<b>p. 18</b>
<b>Blacksmith's Tongs</b>	<b>p. 19</b>
<b>Crane with Pawl</b>	<b>p. 20</b>
<b>Stone Tongs and Self-releasing Hook</b>	<b>p. 21</b>
<b>Catapult</b>	<b>p. 22</b>
<b>Chariot</b>	<b>p. 23</b>
<b>Scaling Ladder</b>	<b>p. 24</b>
<b>Drum Wagon</b>	<b>p. 25</b>
<b>File Cutting Machine</b>	<b>p. 26</b>
<b>Swing Bridge</b>	<b>p. 27</b>
<b>List of Figures</b>	<b>p. 84</b>

## Contents





## The Superstar

■ He was a real superstar of his time. Renaissance is the name of the time (rebirth) and in actuality many things were created or discovered.

Columbus discovered the „new world“ of America and Gutenberg produced the first printed book. Colorless glass and the pocket watch were invented.

## Artist and Researcher

■ Leonardo was a multitalent and not only could he paint and draw, but he was also an architect, nature researcher, engineer and inventor in one person. This versatile talent gave him the epithet of „the Italian universal genius.“

## ... from Vinci

■ But let's begin from the very beginning. When translated, Leonardo da Vinci means Leonardo from Vinci. This is a small Italian town in the vicinity of Florence where his family lived and where he was also born on April 15, 1452.

His artistic career began early in his youth. Here is a small anecdote about this from the life of the young Leonardo:

A farmer gives Leonardo's father a (weapons) shield to have it painted by an artist. But instead he gives it to his son. The young Leonardo, who likes to collect all kinds of animals such as snakes, lizards and bats, paints a mixture of all of these animals, a sort of mythological creature on the shield. His father is so enthusiastic about the drawing that he keeps the shield and later sells it to merchants from Florence, who give him 100 ducats for it (about 350 euros)



The „vitruvian man“ on the reverse side of the Italian one euro coin



■ Young Leonardo did not receive any special school education. At the beginning he couldn't understand Latin, but this was necessary for scientific education at that time. In spite of this limitation he made the best of his situation. He drew his drive and energy from his unquenchable curiosity.

He often wrote „Tell me . . . how, from where?“ on his manuscripts. In most cases, he found the answer to this on his own. Therefore, he called himself *discepolo dell' esperienza* (pupil of experience).

Leonardo liked to occupy himself with animated nature. For example, research in the area of botany, zoology and anatomy, which is the teachings about the structure of organisms, were passed on by him. One sees his drawing of a human being, which reveals, that Leonardo had studied the human proportions precisely.



**The Painter**

Many of his paintings are still world famous today. They are so perfect and beautiful that they fascinate everyone. For example, the portrait of Mona Lisa—the woman with the mysterious smile. Or the Last Supper: An eight meter wide mural in a cloister in Milan.

**The Architect**

He worked for various kings and rulers as an urban planner, designed churches, fortifications, shipping channels, locks and bridges. A Leonardo da Vinci bridge was built in 2001 in Norway according to his original drawings and it certainly is anything but old.

**The Anatomist**

Er studied the structure of the human body and prepared very exact drawings. Since in this case he did not want to rely on the past knowledge from old books, he conducted research himself on human bodies. The drawings were of such precision that many of these are still used today in medical textbooks.

**The Researcher**

An unquenchable curiosity drove him and he wanted to get to the bottom of everything. This was perhaps his most outstanding character trait. The list of his talents could be continued almost without end because he was such a versatile talent.

**His Secret**

... is thinking with both halves of his brain. There is no doubt that Leonard thought using the left and the right half of his brain and thus artistically and logically. Both acted as one. Look at the drawing of the file cutting machine at the end of this activity booklet. It is portrayed logically and isn't it beautiful as well? In addition, he had a very unusual writing style. He wrote from the right to the left with his left hand and now the best thing about this—as mirror writing. He could also write „normally,“ but he found this difficult.

**His Legacy**

Leonardo filled thousands of pages in notebooks. Many of these were lost, however, some were preserved and were consolidated in codices. For example, the Codex Atlanticus consists of 1119 pages and contains many of his machine drawings. If you want to see them, then the best thing is to go to the Ambrosiana Library in Milan or use the Internet. If you want to build the machines and the devices yourself then just look at the following pages and with the help of this fischertechnik construction set bring the 500-year old spirit of the inventor to life.

**The Multitalent**

**Just built today**

**Still being used today**

**Artist and logician**

**Codex Atlanticus**

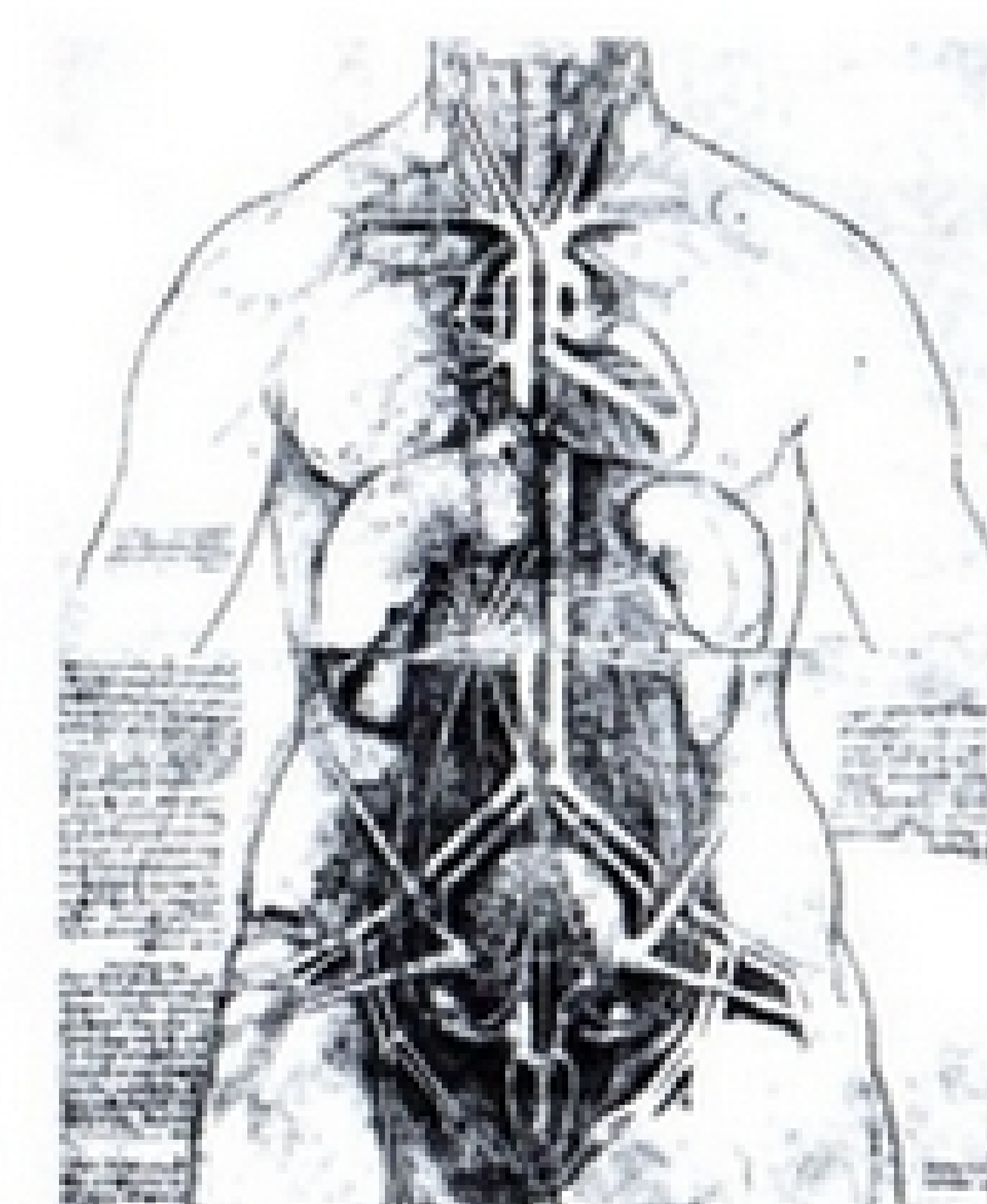
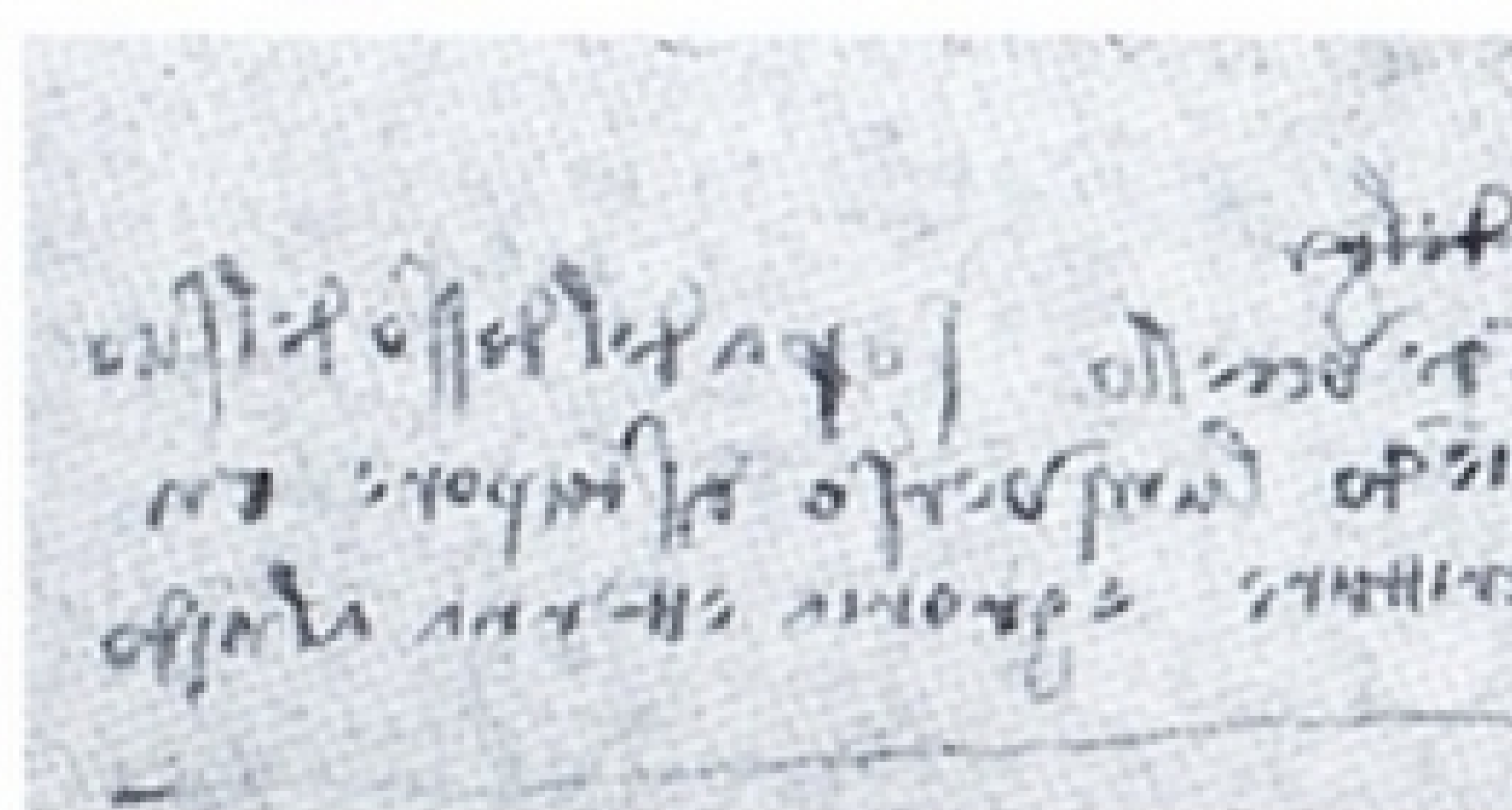



## Mechanical Wings

■ Icarus is supposed to have done this according to a Greek saga. Albrecht Ludwig Berblinger, „The Tailor from Ulm,“ tried this (1811) and Otto Lilienthal did it around 1890: He realized the dream of flying. Leonardo was also fascinated by this.

■ The most astounding achievements today are his efforts concerning flying. The wish to rise into the air like a bird was nothing new at Leonardo's time, but he, the ingenious inventor, came closer to the realization of this with his powers of imagination than anyone before him. Leonardo was also so far advanced in this area that his visions were only slowly turned into reality 400 years later.

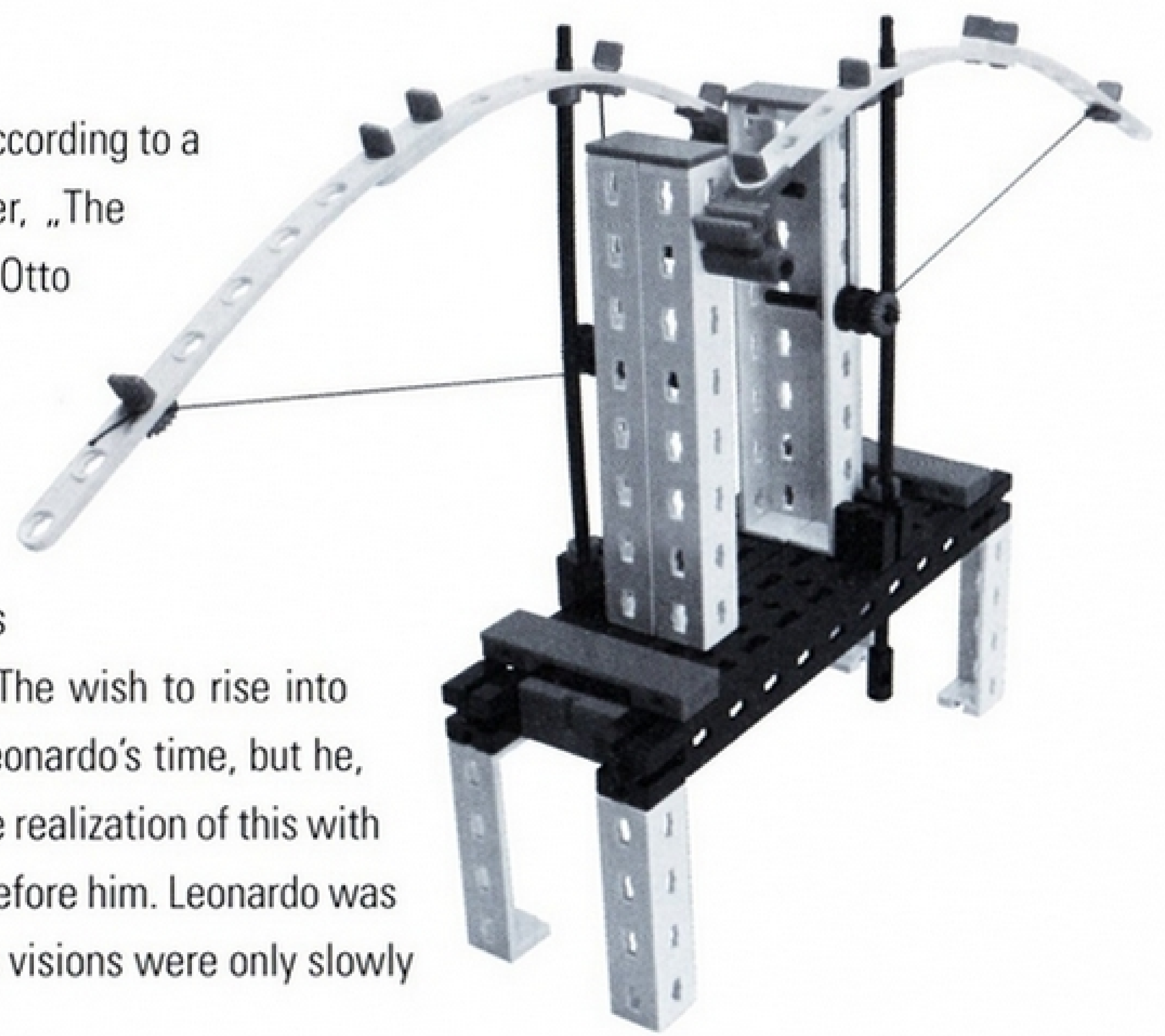

## Copying the wings of the birds.

■ It is about 1490: Leonardo is making observations, studies and experimental arrangements on the subject of flying. When he does this, he looks over nature's shoulder, more precisely those of birds, so that he discovers the smallest details, which are of great importance. He was, so to say, a real bionics specialist even at that time. When doing this, he found that the movement of the bird's wing did not consist solely of an up and down movement, but it's better if you find this out on your own by doing like Leonardo did in his studies, think about the problem, try out ideas and make observations. This design for a mechanical wing comes from the Codex Atlanticus as the basis for an ornithopter. Four hundred years after it was drawn, you can make the wing come alive today.

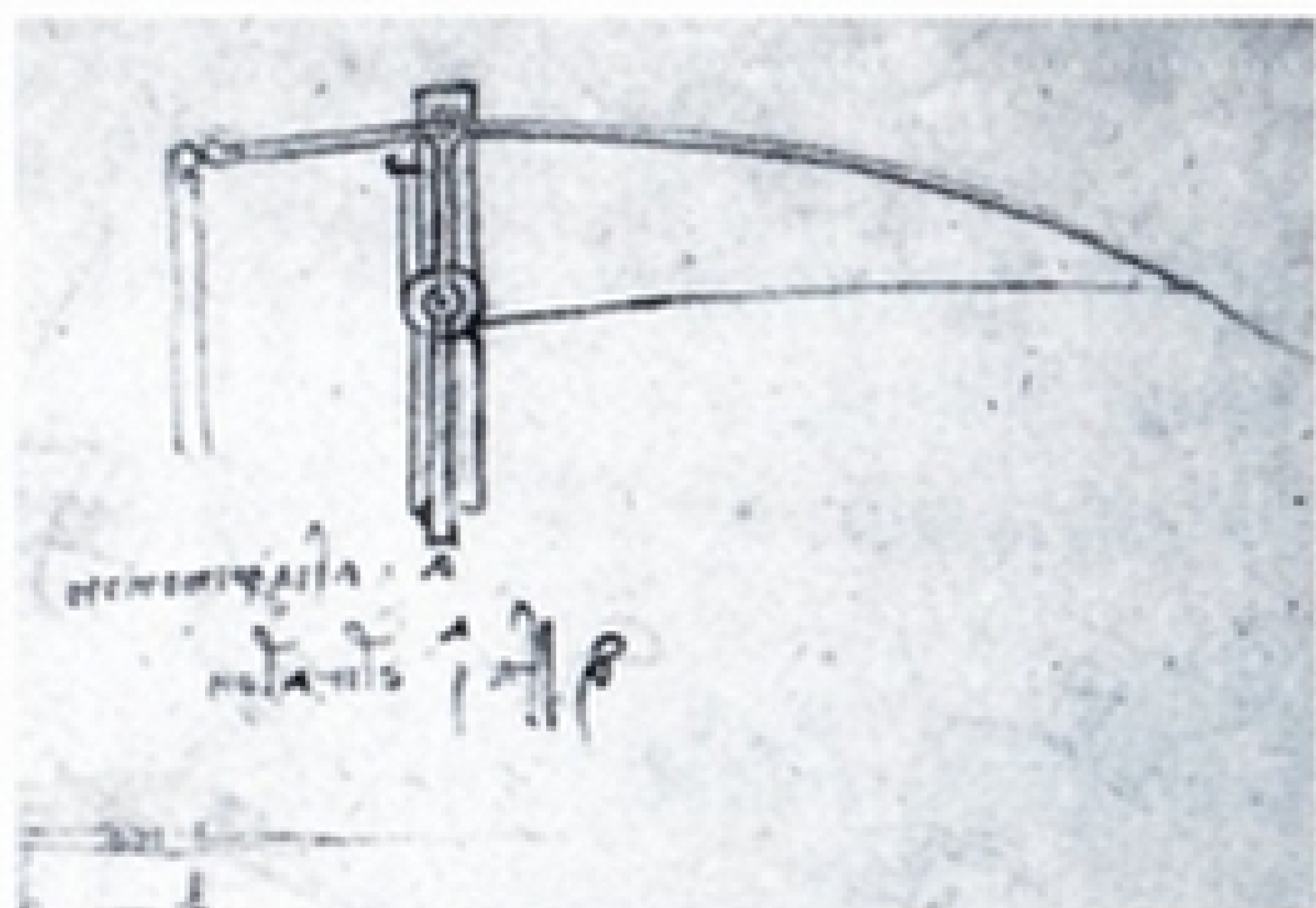

### Your Task

**Build the model and move the wings with the help of the rods. First individually and then together, fast and then slow. What do you notice when you pay special attention to the tips of the wings?**



Exactly, the tips are pulled inwards just like a bird moves the ends of the wings inward toward its body. Now to make a comparison, untie the string on a wing and move it again and you can see what Leonardo caused with this simple „rope trick.“

What do you think, was Leonardo finally able to fly with one of his machines?

Unfortunately no. Leonardo didn't have the right drive. The power of the human muscles was not sufficient to do this. But many of his ideas were put into practice hundreds of years later, for example, the helicopter.

*Observe the swimming of the fish in the water and you can understand the flight of the bird in the air (Leonardo da Vinci).*



■ Leonardo also made efforts to make work easier and safer for people. He developed machines, which even did the work for people. The machines were often gigantic or very complicated. However, the example of the blacksmith's tongs shows that this can be done differently namely with small and simple, but clever solutions.

The craft trade of the blacksmith was everything else, but easy work. In the smith's shop, it was hot, the hammer was heavy and also you had to really bang the workpiece hard as long as it was still glowing. Yes and the forged piece had to be held in the tongs by hand with a lot of strength during the entire time. Well, sometimes your fingers could get really tired.



## Blacksmith's Tongs

**Being a blacksmith is hard work**

■ Leonardo was able to kill two birds with one stone here using his special tongs:

He simply put screw threads in the handle of the blacksmith's tongs. On the one hand, to increase the tension force, which holds the forged piece securely. On the other hand, it is a good way to save an extreme amount of energy if the blacksmith does not have to continually exert force on the tongs with his own muscle power.

**The trick with the screw**

Advantages

- Easy to use
- High tension force
- Safe and energy saving holding of the workpiece

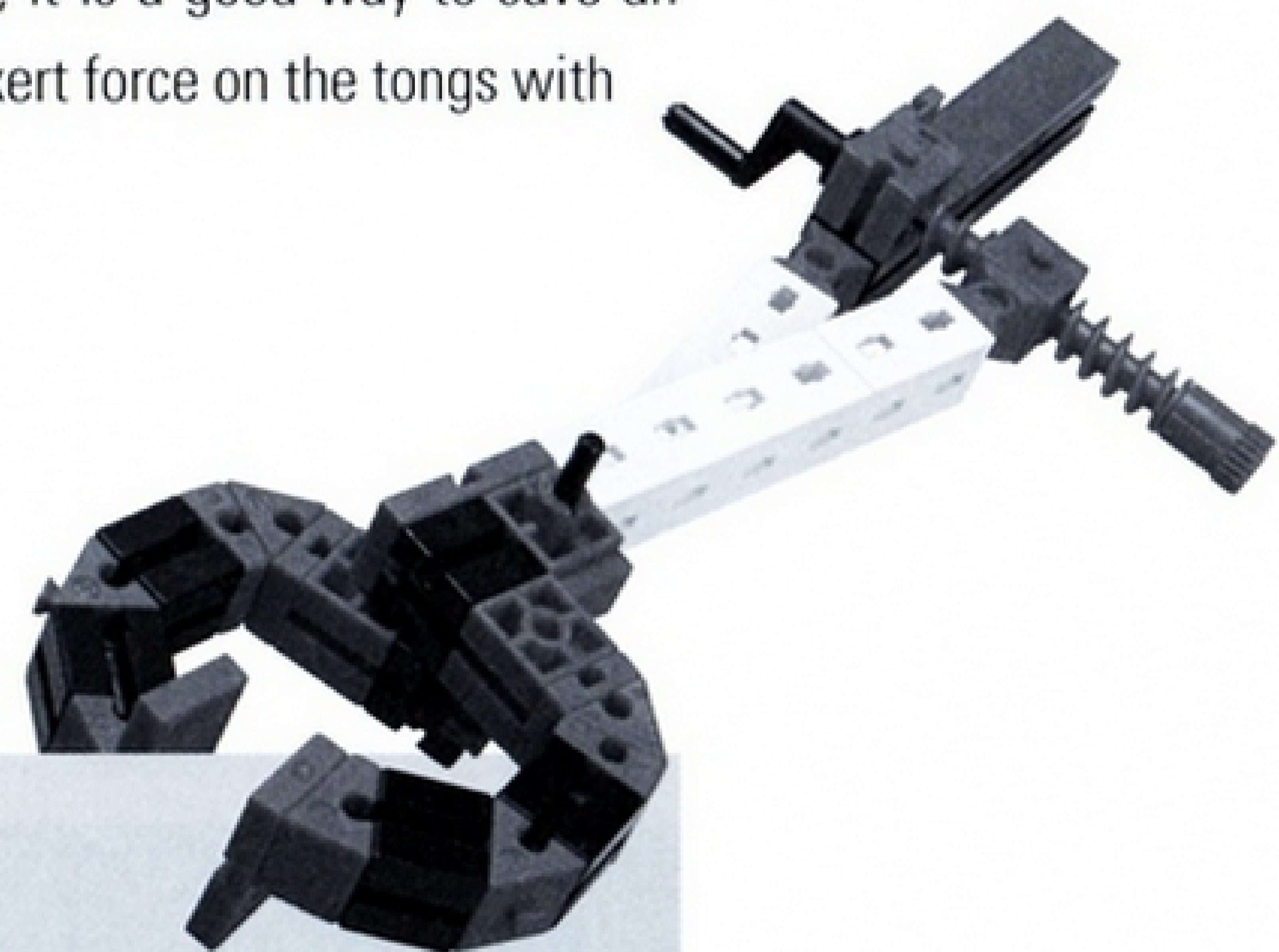

### Your Task

**Today, the profession of the blacksmith has become rare and thus the use of the blacksmith's tongs as well. When could you still use the tongs today?**



For example, when gluing things together you could press the parts to be glued together until the glue hardens.

Play around with the tongs a bit and think about where you can still use the tongs.

*Just like iron that rusts when it is not used and standing water becomes stale or freezes when it is cold, the same applies to the mind without exercise (Leonardo da Vinci).*



# Crane with pawl

## Safety belt of the 14th century

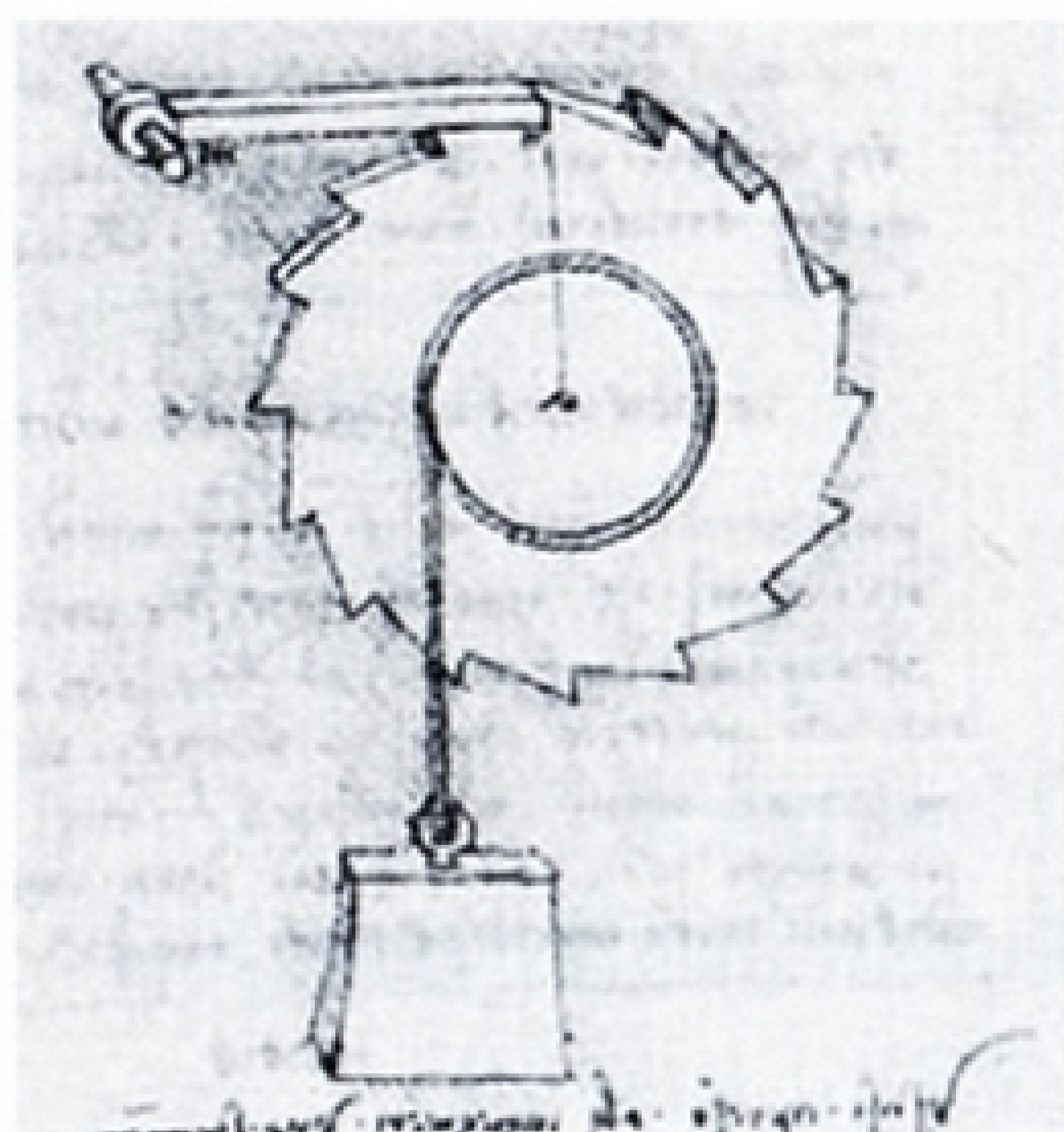

■ This invention is an example of how Leonardo had thoughts about the safety of his fellow people. If you would compare this with today then the pawl would be something like the safety belt of the 14th century. There were namely many accidents, serious injuries and even deaths when heavy loads were lifted with the crane, for example, on ships, horse drawn wagons or at construction sites. With the pawl, it was now possible to lift and hold big heavy loads without endangering the workers standing underneath it.

■ The pawl mechanism consists of a toothed gear with sharp teeth and a blunt hook, which can catch in every of the individual gaps between the teeth. The hook is placed so that it glides over the teeth in one direction of rotation, but catches in the teeth when it moves in the other direction.

■ You can lift the weight with the model by turning the crank. If you let go of the crank, the weight is held securely in position by the pawl. To let it down, you must hold the crank firmly and raise the pawl slightly and lower the weight slowly with the crank.

Do the following as a comparison: Crank the weight up to half of the height. Now disengage the pawl and observe how fast the weight now races down. Who would have had a chance to run away fast enough under this?

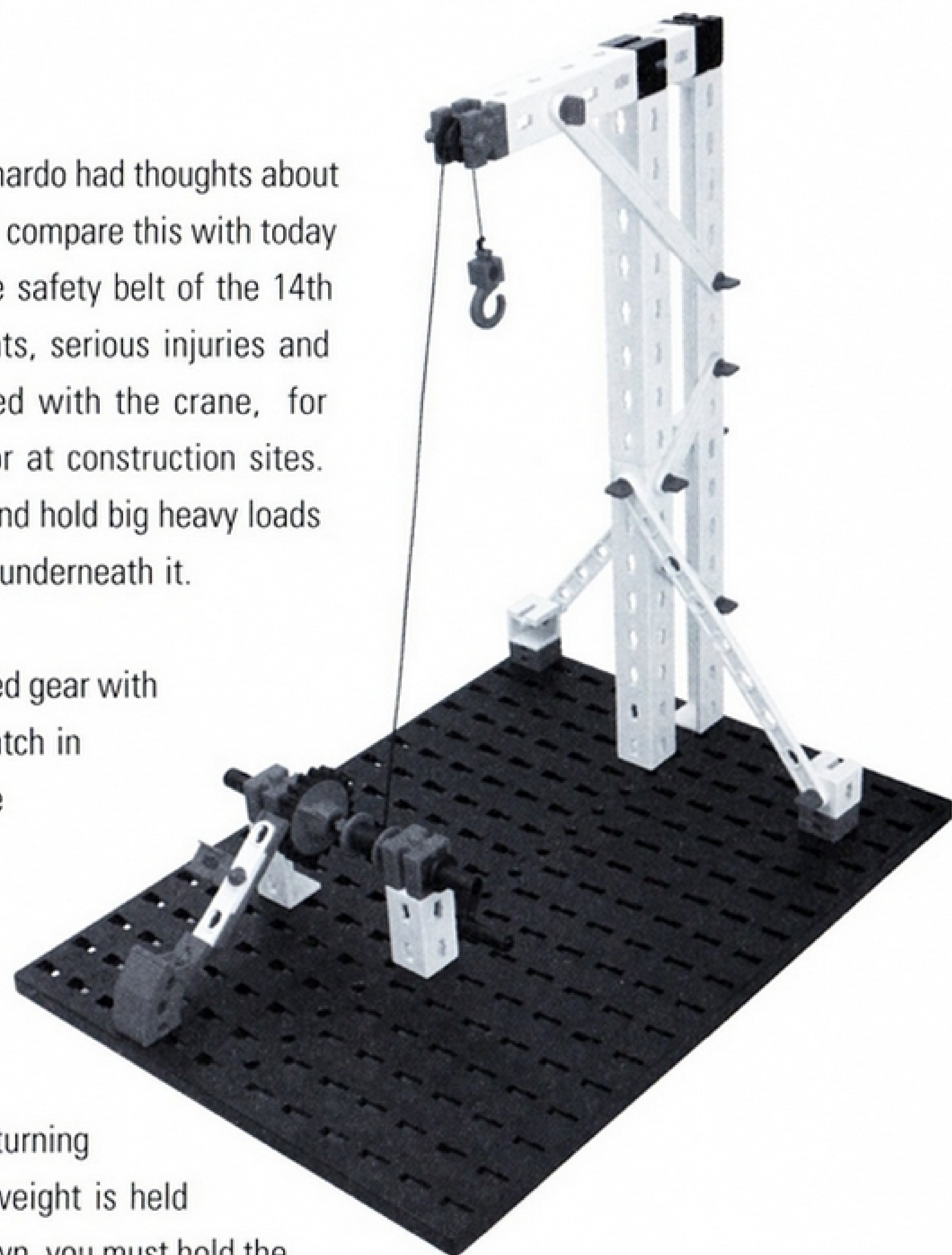

### Your Task

**Just like so many other inventions by Leonard, the pawl is still being used today. Can you think of an example?**



**Tip: Listen to the sound of the pawl when the crank is turned. Have you heard this before?**

The solution in Leonardo's way of writing:

Further examples are clocks, door locks and handcrfts. There are even two pawls built in there. If you have used a tool from a socket wrench box, then you have certainly handled a ratchet (lever brace).





### Stone Tongs

■ In 1466, Leonardo's family moved to Florence. Florence was a center for money and trade and attracted artists and creators. Leonardo was lucky and when he was 14, he was able to become an apprentice with the most famous artist at that time, Andrea del Verocchio. It was a time when Florence was rich and powerful. Much construction was made because the city was supposed to become bigger and more beautiful. When Leonardo went to his traineeship in the morning, he passed numerous construction sites and observed the people doing their work. It was physically hard work and one of the reasons was that there were few machines to support the work. It is probably these impressions, which were the reason that he later designed so many cranes and tools for building.

■ Such as the stone tongs. It is a simple device, but contains an ingenious mechanism. Of course, you can hang the tool on the crane hook and lift the most varied of loads with this. When you do this you will notice that you never have to tension or clamp the tongs. This does this namely completely automatically. And this is just not a simple action because the heavier the load the harder the tongs clamp the load and bites right into the load, here the stone. You don't believe this? Then try the following.

## Stone tongs and self-releasing hook

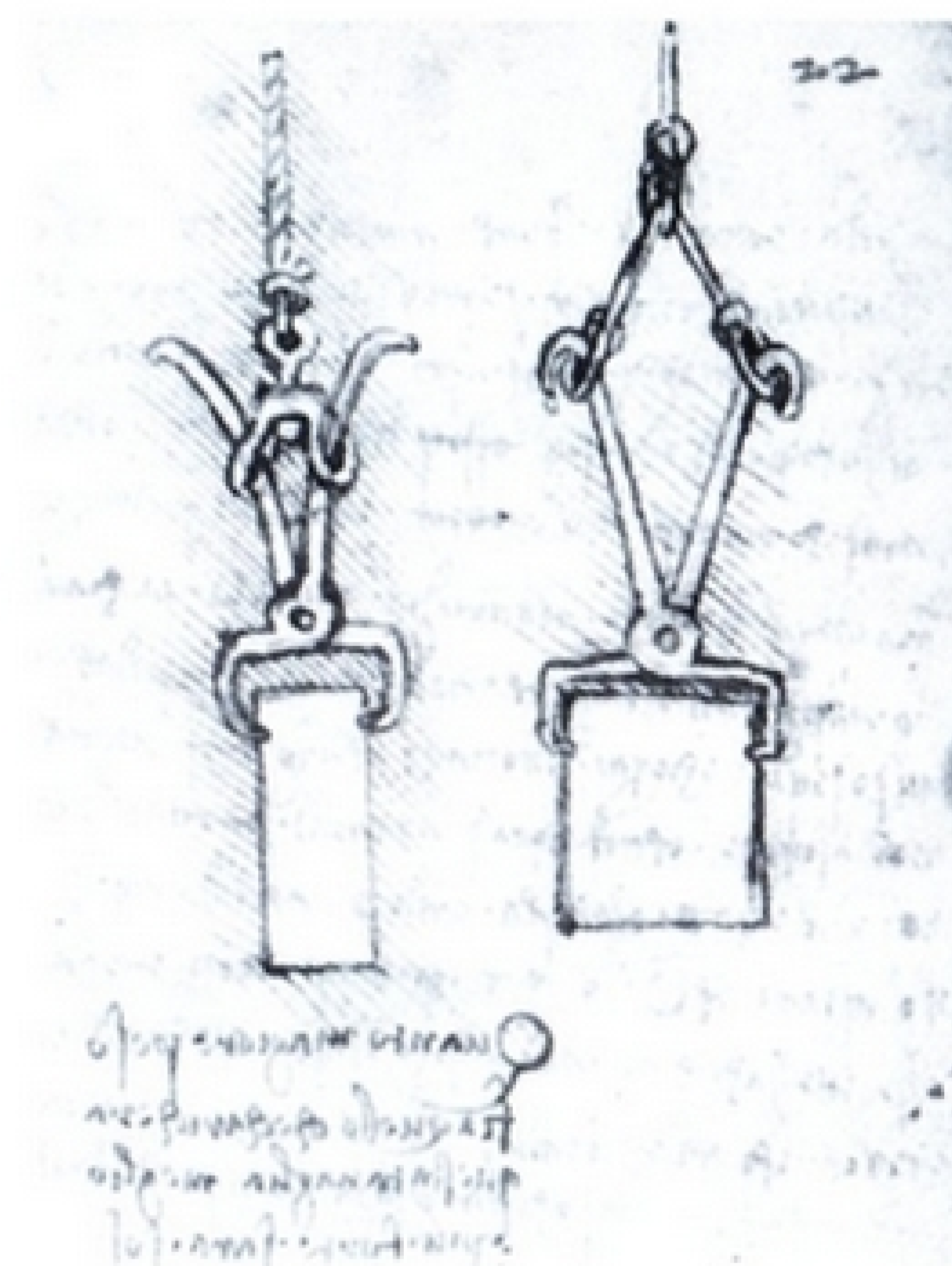

#### Your Task

**Stick your index finger between the jaws of the tongs and thus you are simulating the load, here the stone. Hold the string with the other hand (this is supposed to be the hook). Now make the „stone“ heavier by trying to pull your index finger down out of the tongs.**



Can you feel how the tongs, „bite in?“ Now don't say that this isn't brilliant!

### Self-Releasing Hook

#### Your Task

**Replace the normal hook on the crane with the self-releasing hook from Leonardo da Vinci. Pull the hook up to half of the height. Now hang a weight on and slowly let it down.**



Shortly after the weight touches the ground and thus takes the load off of the hook mechanism, the hook tips up and releases the weight, which was placed on the hook.

You may ask: „Okay fine, but what is the purpose of this?“

At a construction site, this hook is worth that of an entire man. This is because loading always required at least three people. A crane operator, one person to hang the load on (basket with building stones) and another person to take the basket off at the unloading location and it is precisely this person who can now do something better.

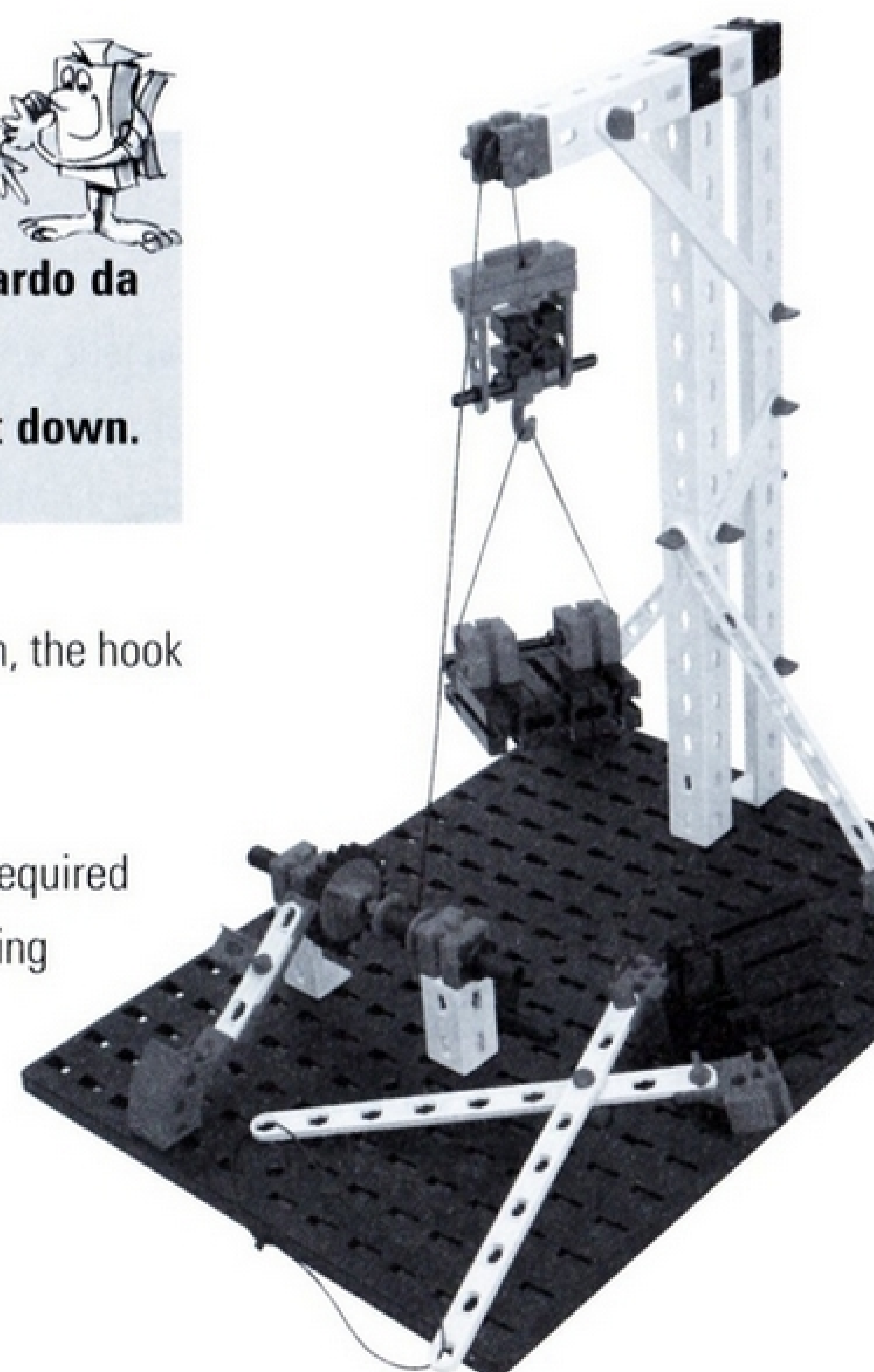



## Catapult

■ At the end of the 15th century, Leonardo was about 35 years old and the political relations were very uncertain. He was continually involved in wars. Leonardo deeply detested war. However, his capabilities in the areas of architecture and the construction of machines were much in demand with the various rulers. He was supposed to design fortifications and invent weapons for them. Catapults were well-known throwing machines. For the development of his new catapult, Leonardo was mainly concerned with the principle of the spring mechanism.



### Quick tensioning device and release catch in one

■ The machine obtained its throwing energy from the pretensioned leaf springs, which transmitted their energy over the roller to the catapult arm. At that time, the two big leaf springs were of course made of wood and developed an enormous tension force. With a special tensioning device, it could be reloaded in a short time. And the best thing about it was the self-locking mechanism. Namely, most of the catapults had to be prevented from premature springing back with pawls or similar devices. Otherwise, it could happen that the catapult went off only halfway back and only with half of the force.

## Worm gear

■ As so often, Leonardo had a brilliant solution, the worm gear. He killed two birds with one stone with this. A smooth running drive for tensioning and a safety locking device, which was built-in, to prevent it from springing back.

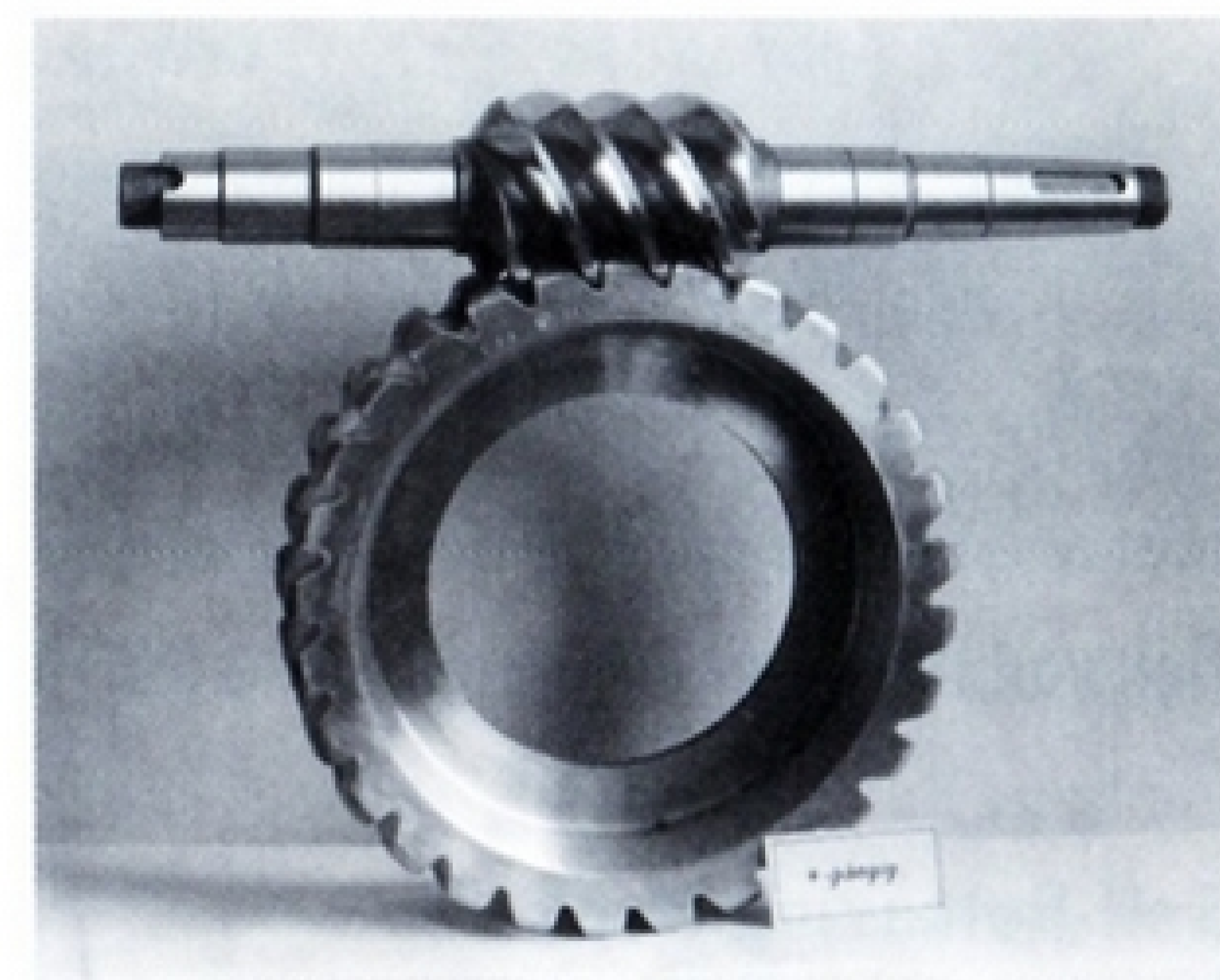

### Experiment

How far can you catapult a building stone?

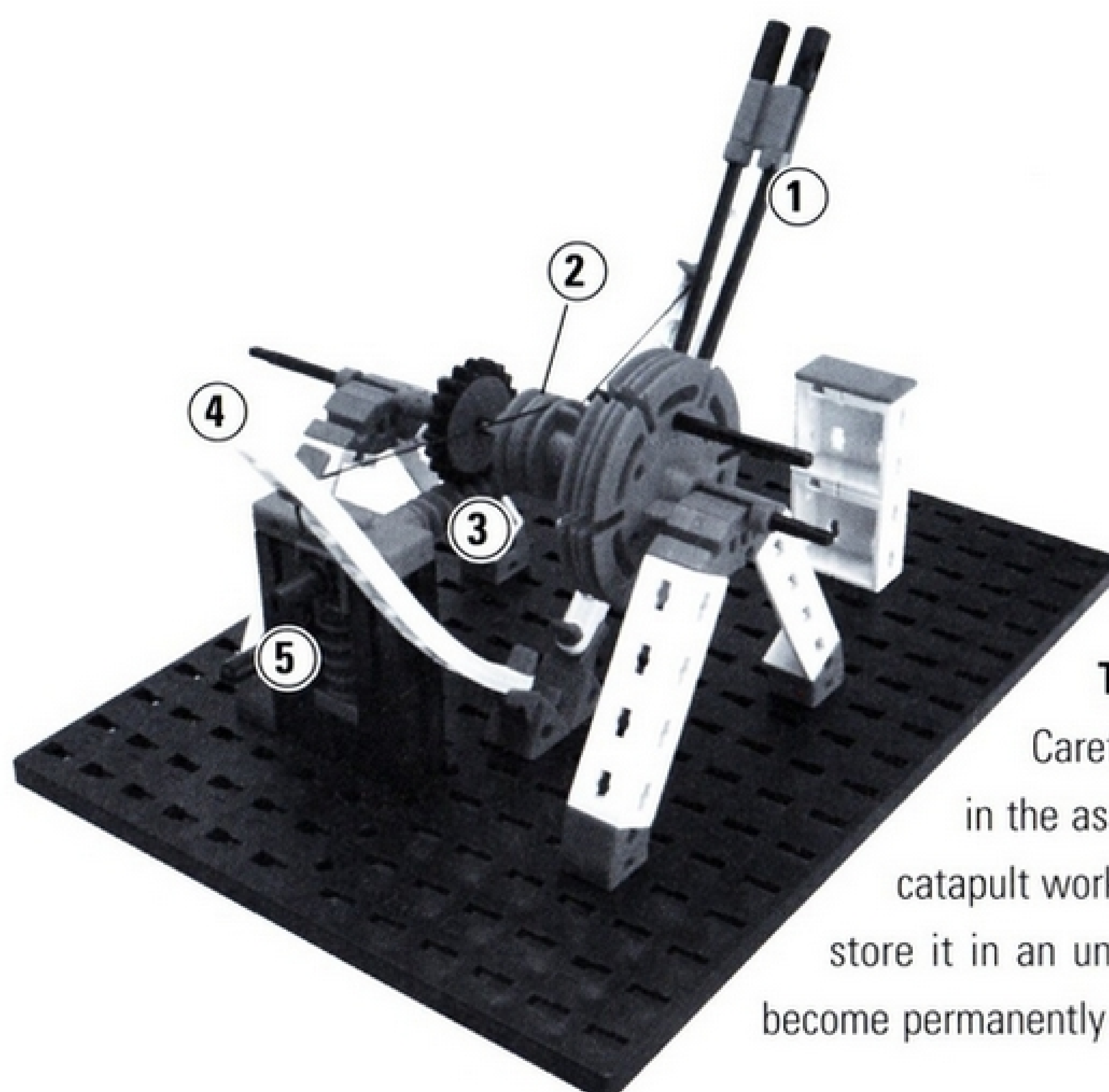

1. Catapult arm
2. Roller
3. Worm gear
4. Leaf spring
5. Tensioning crank and releasing mechanism

### Tips:

Carefully follow the instructions for tensioning the rope in the assembly instructions. Then this guarantees that the catapult works properly. As for every catapult, it is better if you store it in an untensioned state. Otherwise the tensioning bows become permanently warped and the catapulting force declines.



■ The military engagements took place on the battle field in most cases. The enemy troops stood in lines opposing each other. Breaking through the line at one point to then attack the enemy from the rear was often a maneuver, which was deciding for the war. On the one hand, the enemy was not able to defend itself well there and on the other hand he suddenly had to fight on two sides.

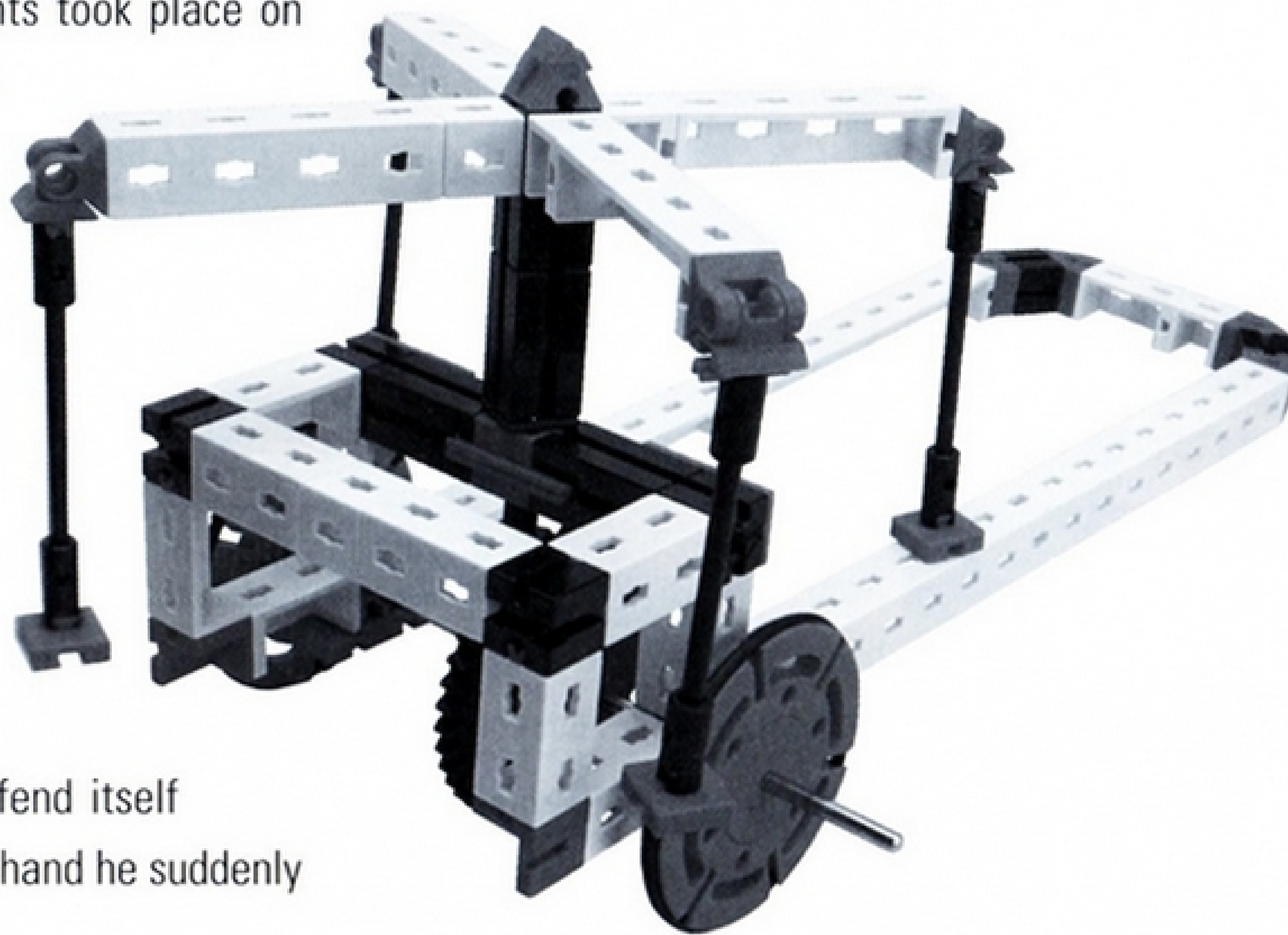

The chariot was ideal for the breakthrough. This was because anybody who saw this wagon approaching him got out of the way. Then following this wagon, the troops on this side could storm through the gap.

## Chariot

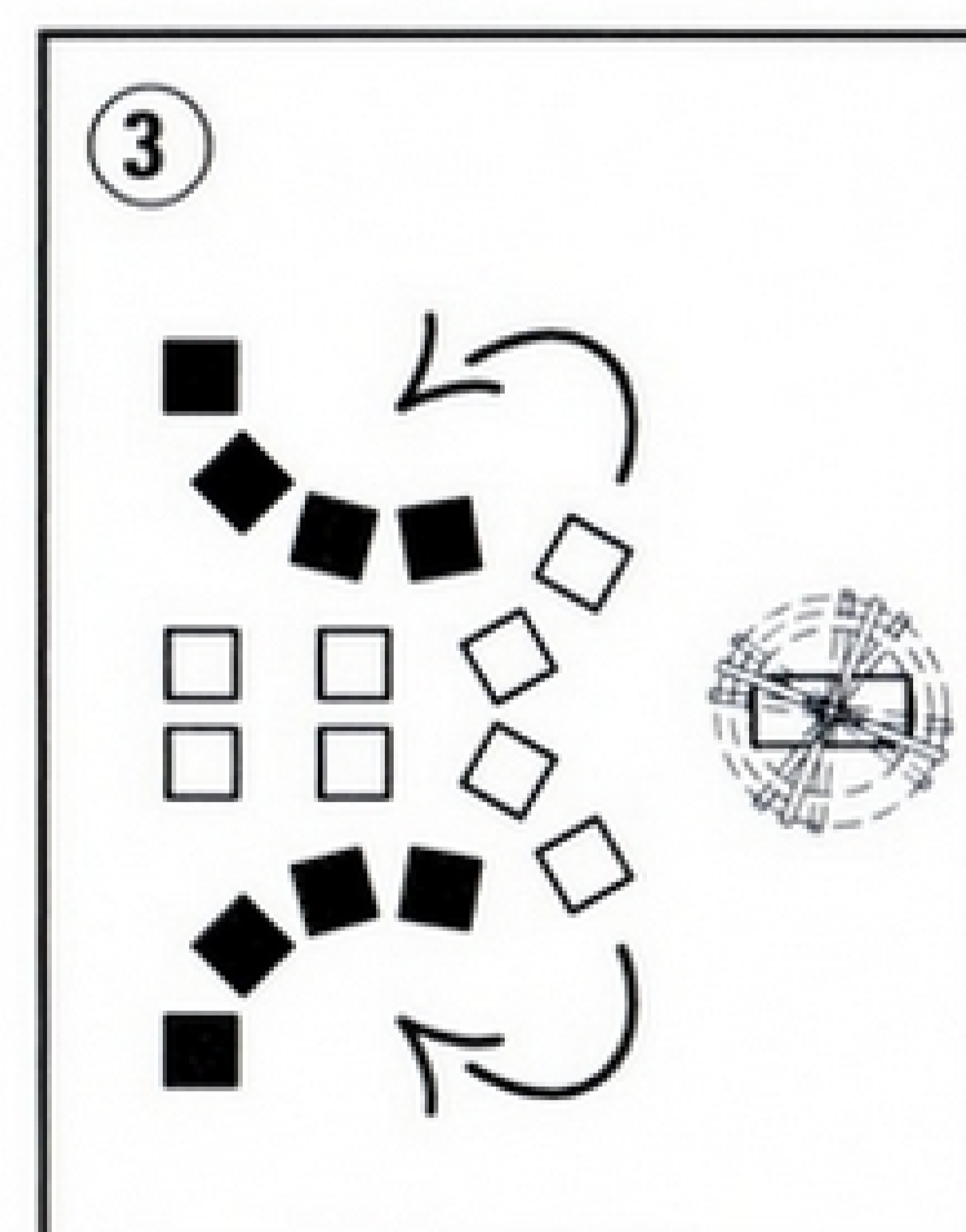
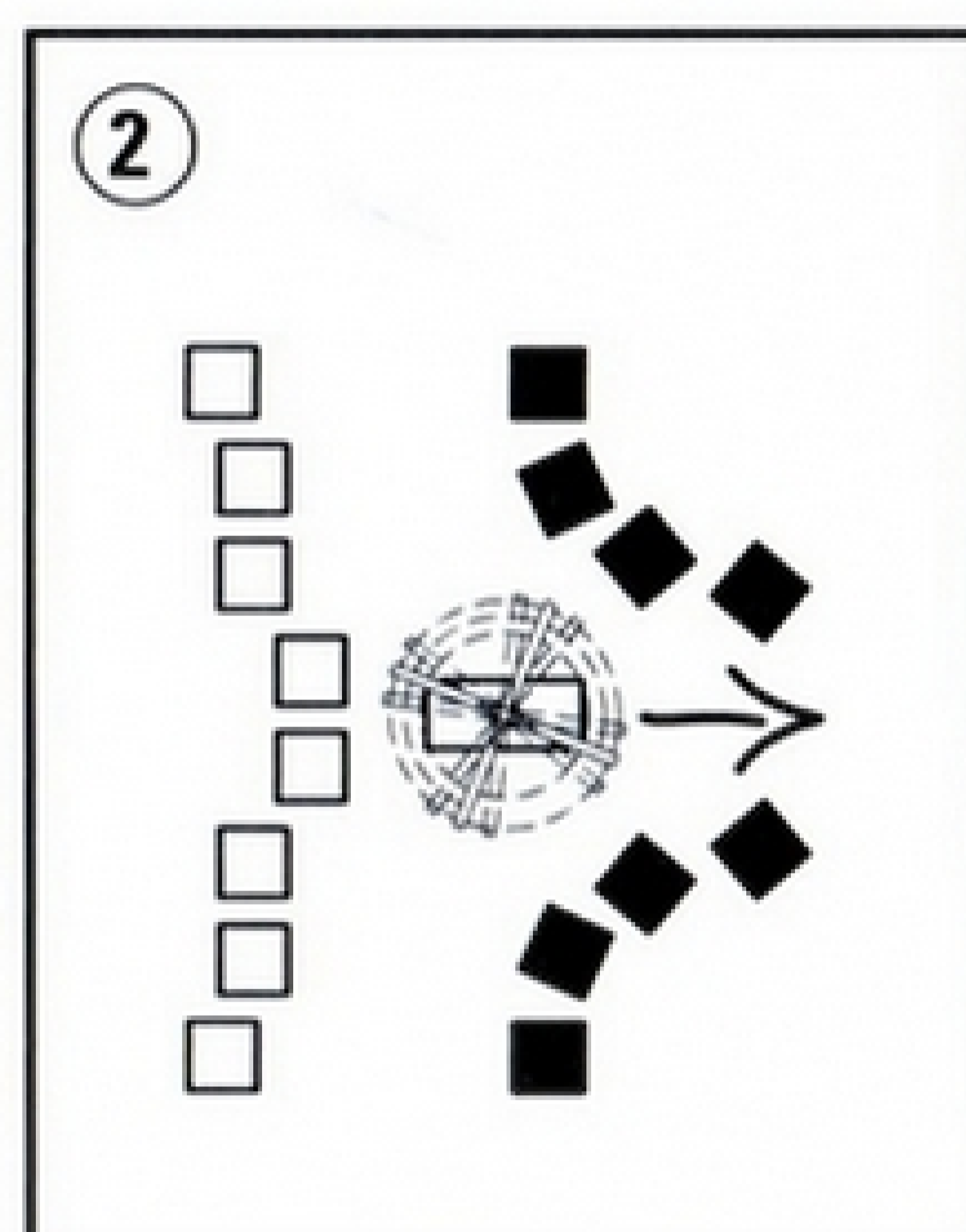
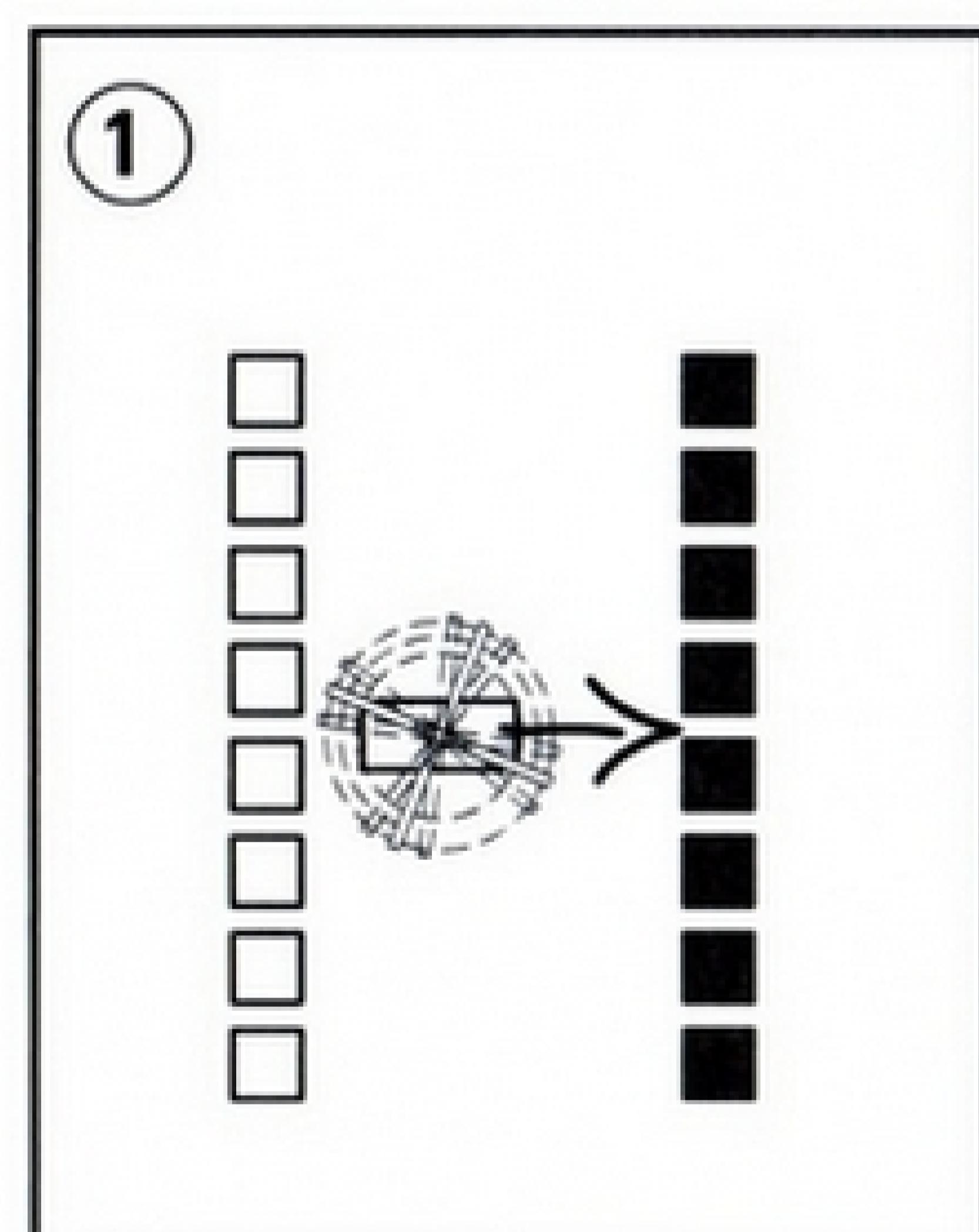
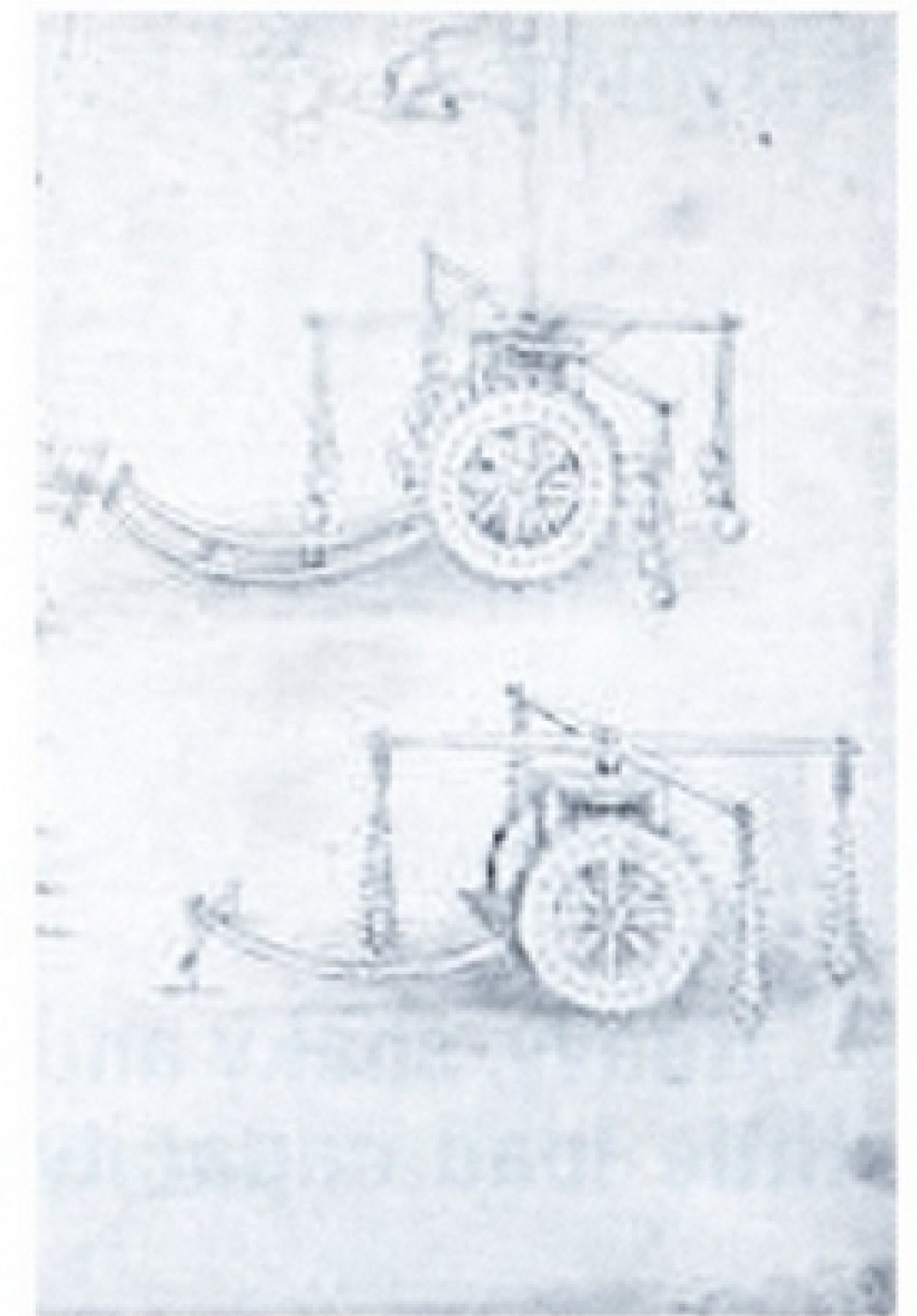

1. Advance quickly
2. Break through
3. Engage from rear

■ Leonardo installed a contrate gear in the axle, which connected both wheels. This has the special characteristic of transferring a rotational movement by 90 degrees and in this case from a horizontal axle to a vertical axle. When he did this, Leonardo use teathed gears of a different size. The result of this was that the rotational speed changed. The big toothed gear, which is the drive gear, had 32 teeth and the driven small toothed gear only had 10 teeth. When the big wheel rotates one time, then the small one turns three times in the same time. The small toothed gear can only do this if it turns faster, which is about three-times as fast. The term also applied here is a transmission ratio of one to three or 1:3. It is exactly this acceleration effect that Leonard wanted. It is only when the rotor rotates fast, that sufficient centrifugal force is created to drive the heavy weights, which have been attached, outwards. You have already felt the effects of centrifugal forces on your own body. For example, when you are sitting in a chain merry-go-round, it forces you outward, but at the same time if lifts you up and presses you into the seat.

**Centrifugal force up close**



## Scaling ladder

■ The scaling ladder was also called the wall breaker and thus described the purpose of the ladder better. In the Middle Ages, it was an important implement of war. Using this, the attackers were to climb the wall of a castle or fortification, fight their way through, open the door from the inside and let the waiting troops in.



## Heavy, shaky and little load capacity

■ So much for the theory. In practice, this was no easy job. In addition, the lords of the castle adjusted to this. The walls of the castle were built higher. The ladders had to be extended and due to this became heavier, shakier and could hold less of a load. Due to the decreased load bearing capacity, not too many soldier could use it at the same time. If the attackers, who intended to scale the wall, were discovered then it was easy to push them and the ladder away from the wall.

## The turntable ladder

■ However, there was a very popular and ingenious inventor by the name of Leonardo da Vinci, who was asked to provide advice

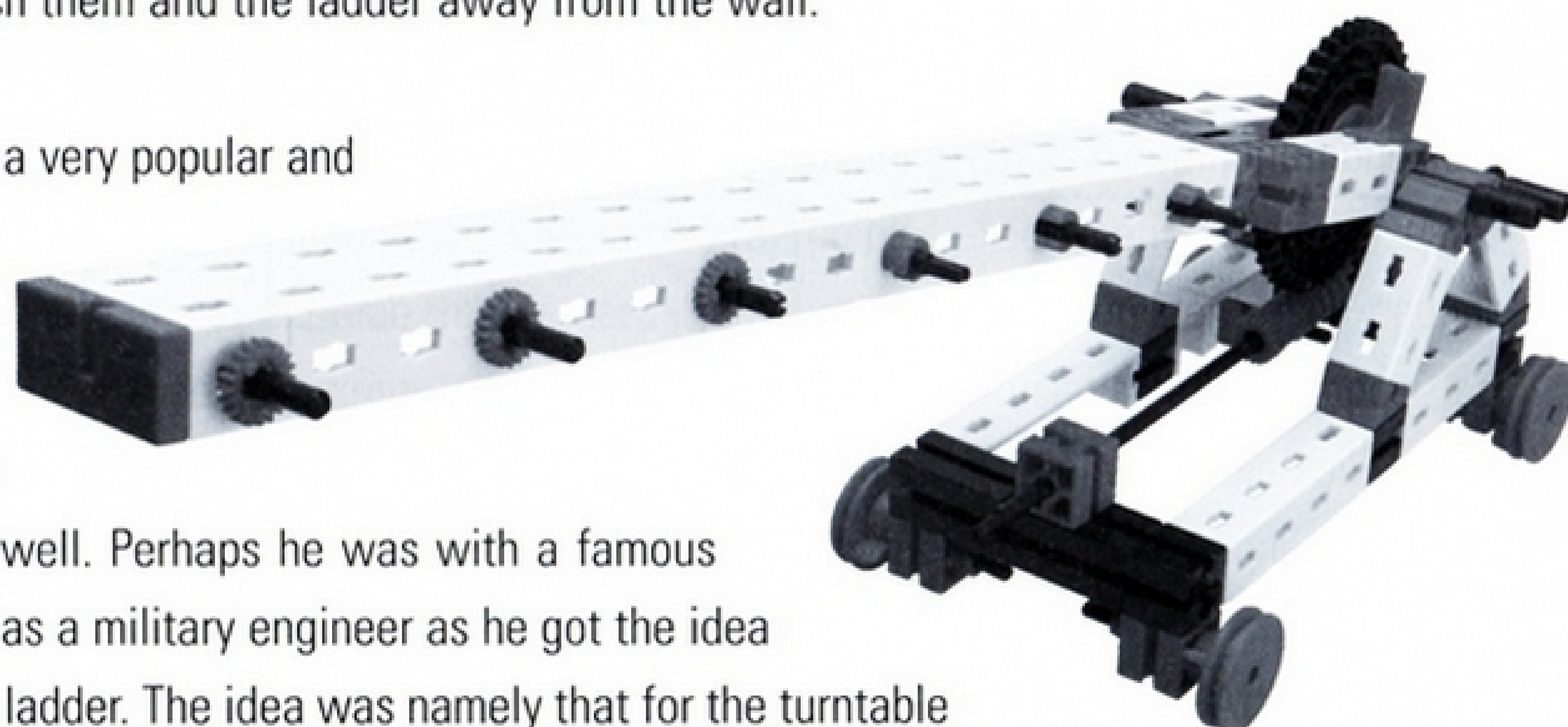

about this problem as well. Perhaps he was with a famous statesman and serving as a military engineer as he got the idea about a special scaling ladder. The idea was namely that for the turntable ladder as it is called today. It was long and stable. It could hold several soldiers at the same time and the height was infinitely adjustable. It was mounted on wheels and at it was quickly taken to the operational location and could not be pushed away.



### Your Task

Even if Leonardo da Vinci has long since died, many of his ideas are still alive or were even rediscovered in today's time. For example, the parachute.

The principle of his scaling ladder belongs to the first category. It is still alive and it is even saving lives. Do you know where?



The solution in Leonardo's way of writing:

The fire department would have twice as much difficulty without its turntable vehicle.



■ Leonardo's versatility is also shown by his musical abilities. He composed operas, organized celebrations with musical performances and he himself had a good singing voice and in addition designed his own music instruments. One of them had keys like a piano, but had strings on the inside and a bow like a violin. Another one looks like the head of an animal and inside there is a \*barrel organ. However, the percussion instruments must have interested him the most because there are many designs for these.

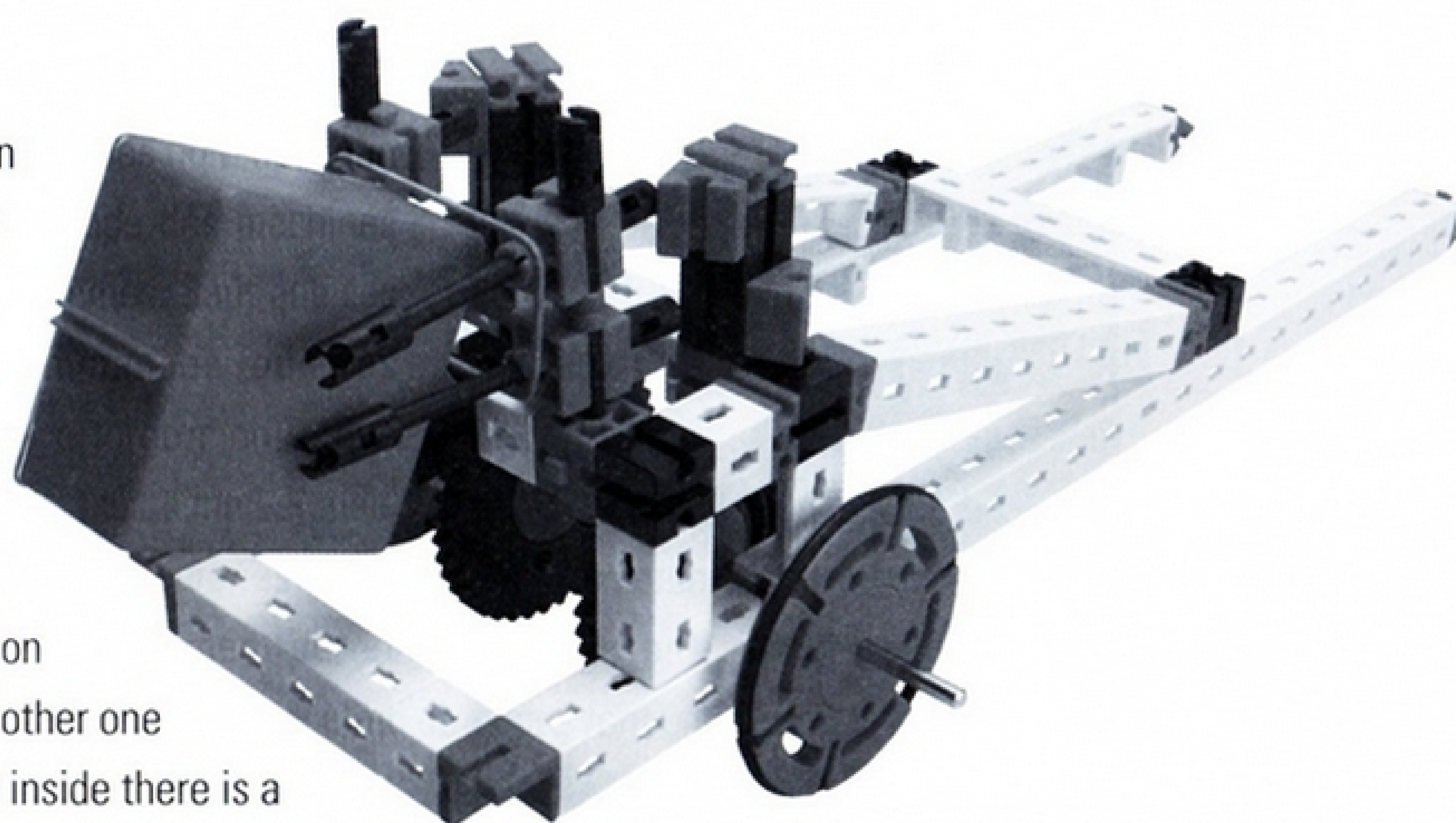

## Drum wagon

■ Leonardo probably intended the drum wagon for parades. However, perhaps also for use in war to scare and confuse the opponent with unusual noises.

## The art of war

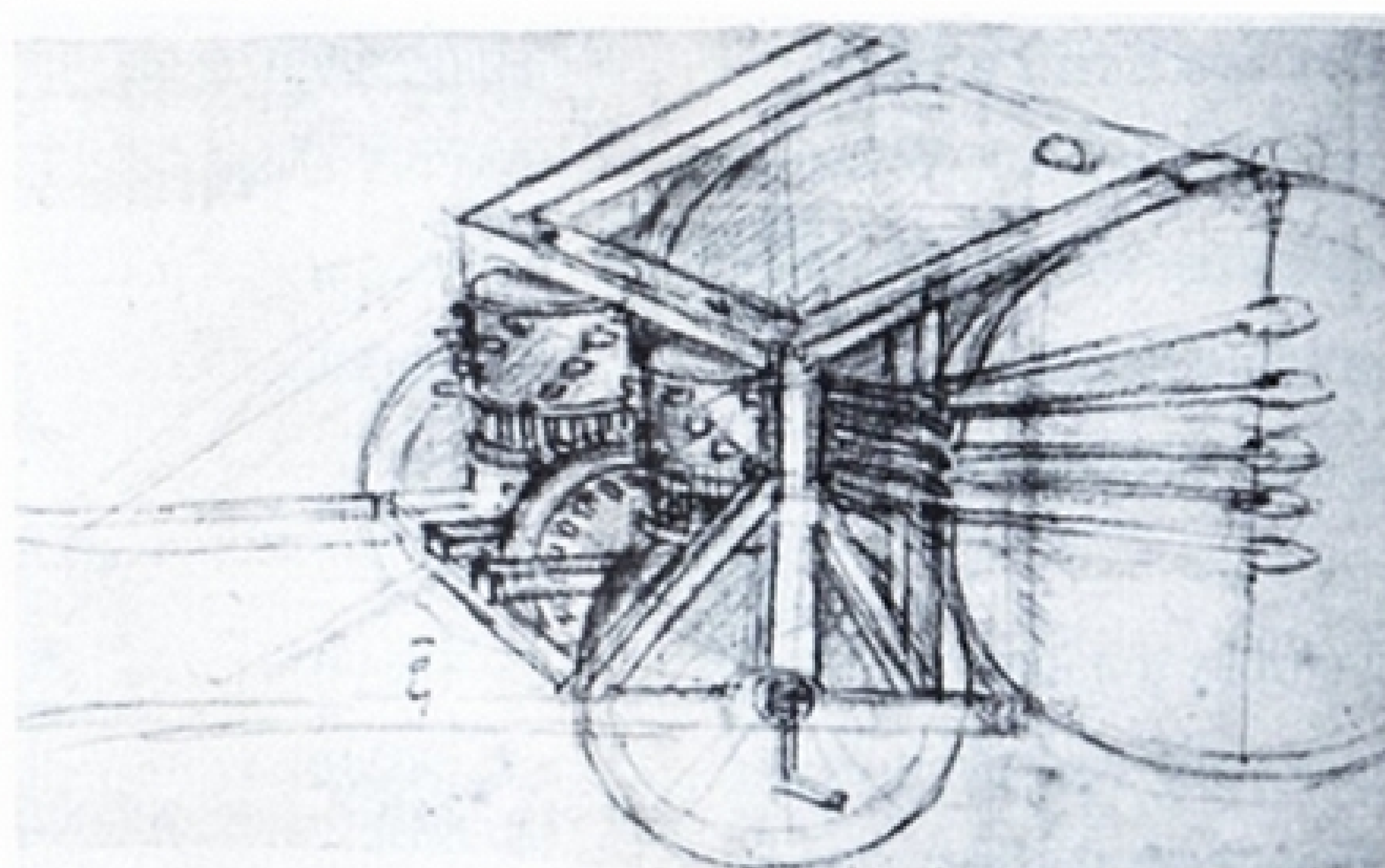

■ The original was almost completely made of wood and the drumsticks were operated by replaceable wooden pins. This provided the capability of setting various rhythms.

## Adjustable rhythm

### Your Task

**You can also „reprogram“ your drum wagon. Move the angular stones to the other side of the black building stone and when you do this you change the beat of your drum wagon.**



A note about the function: The drum wagon is designed for a certain direction of travel. This means do not shove it like a wheel barrow, but pull it like a coach.

## Note!

\*Barrel organ is a string instrument, where the strings are stroked by a wheel, which is installed and is rotated by a crank.



## The file cutting machine

■ For this machine, the drawing itself is a small work of art. Leonardo was just not a technician or a painter, he was always both.

The equipment can beat indentations into a file blank completely automatically. And this can be done faster and more precisely than a person can do it. This thus mechanizes and automates a difficult work process. Today this is the basis of industrial manufacturing. It is amazing that Leonardo not only recognized this, but also implemented this in the form of a machine 500 years ago!

### Starting the machine

■ Wind up and start the file cutting machine.

The complex system is similar to clockwork. First, you have to „wind it up“ by cranking the weight upwards.

**Note!** When doing this raise the hammer slightly, so that it doesn't catch.

If you let go of the crank and the hammer, the „clockwork“ begins to run automatically.

- The weight (1) drives the axle over the spool of string.
- The axle sets two systems in movement at the same time:
  1. The contrate gear (2) with the help of the spindle shoves the carriage (3), on which the file is lying.
  2. In synchronization with this, the cam wheel strikes the lever (4), which operates the file hammer.
- When the weight on the string reaches the floor, then the file is finished.

### Reduce friction by adjusting

**Tip:** If the hammer does not strike uniformly, but sputters or is stuck, then you can take care of this problem by insuring that all shafts turn easily. If necessary, adjust the teathed gear and bearing a bit. A little forward or backward, just try it out.

When it then just really rattles almost like a woodpecker in the forest, you have optimally adjusted the file cutting machine.

Follow the instructions for placing the model in operation in the assembly instructions.

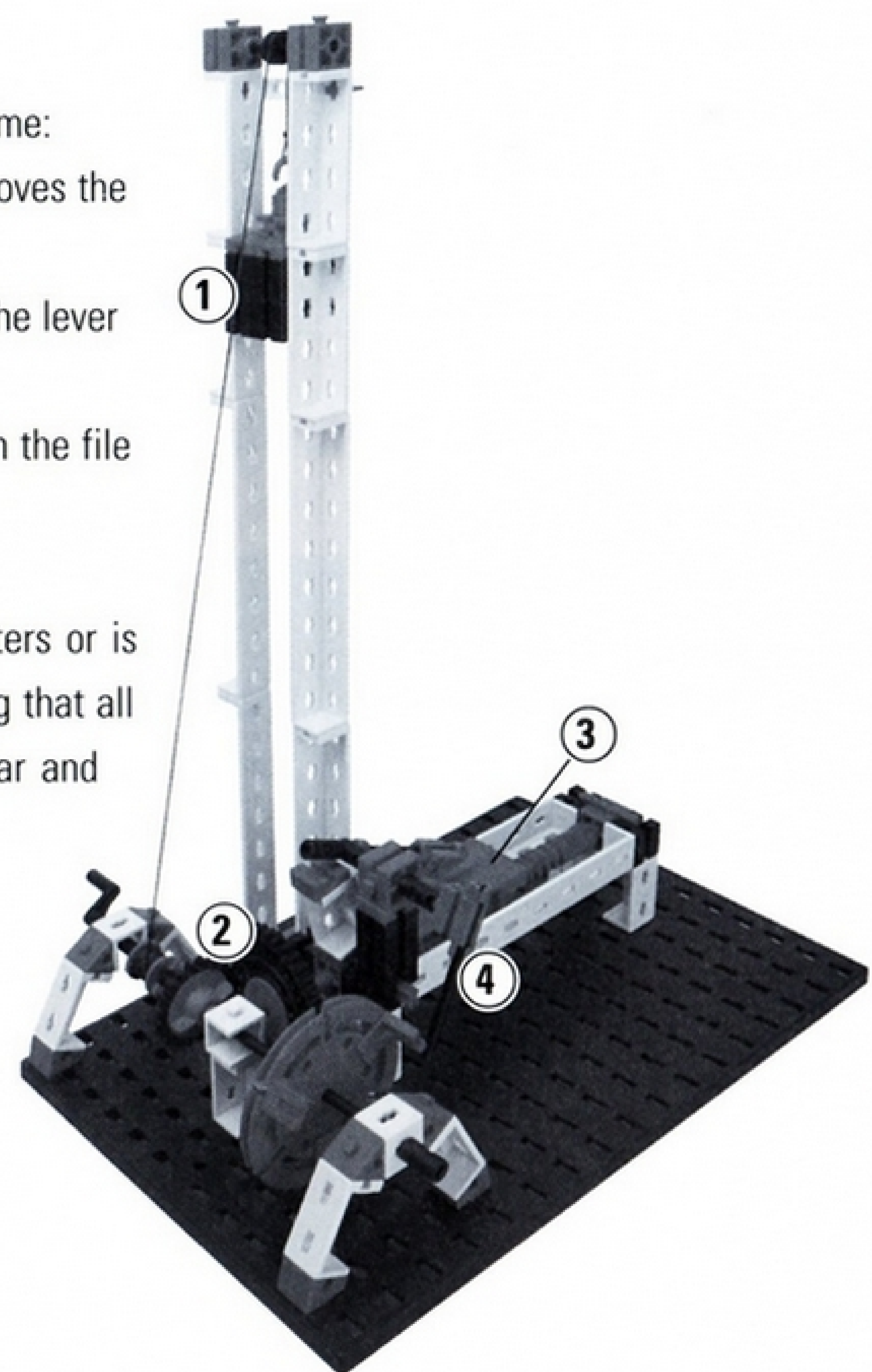
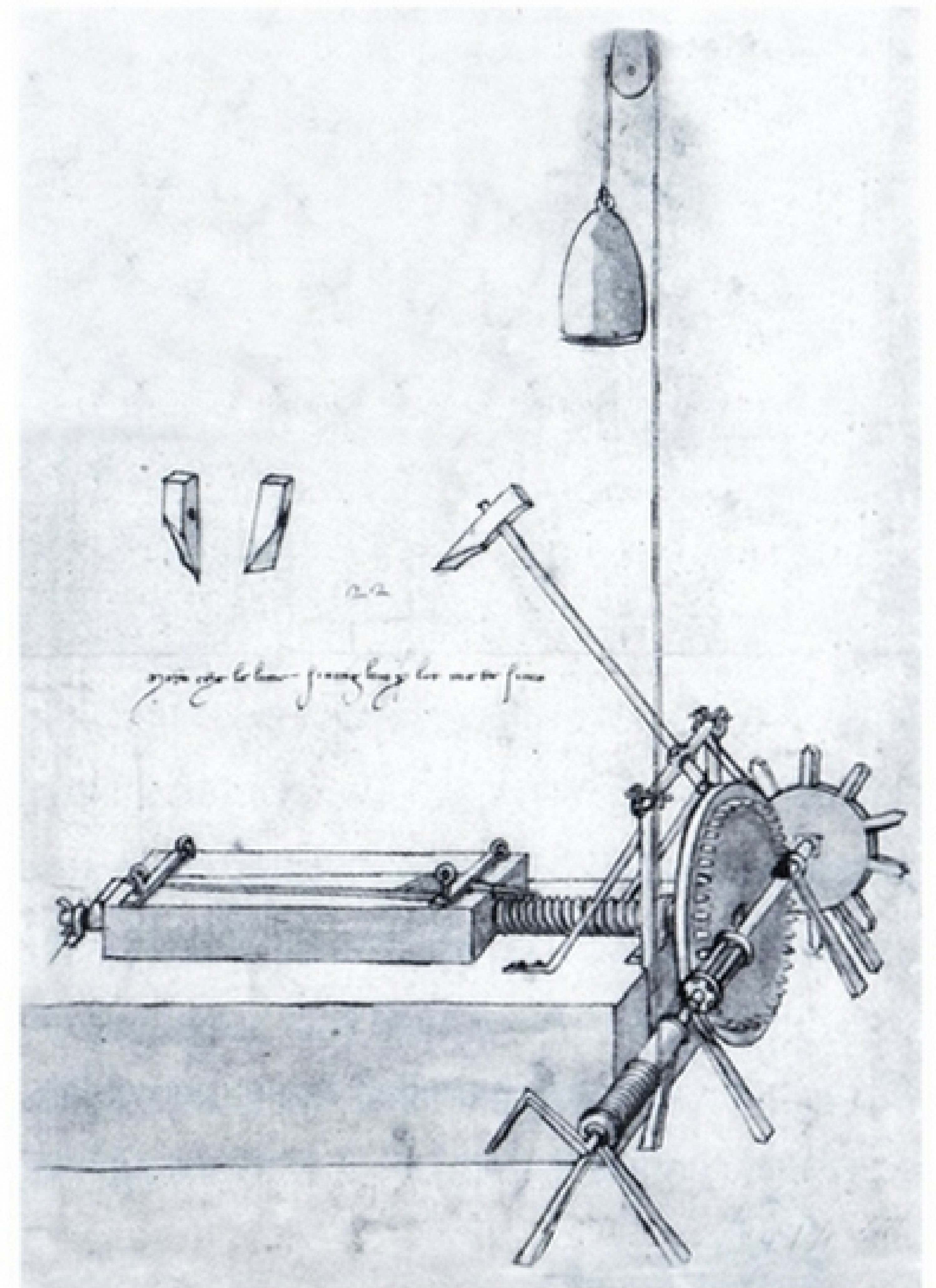



**Your Task**

Start by „pressing the button.“ Can you improve Leonardo’s machine? For example, by installing a safety mechanism, which makes it possible to allow the machine to remain woundup and then start it by pressing a button?

Keyword: Pawl (see model crane).



■ The Bosphorus Bridge:

As a universal talent, artist and inventor, Leonardo da Vinci was not afraid of hardly any task. He was also not afraid to build a big bridge over the Bosphorus! Conceived in 1502, it was supposed to reach the span of 250 meters, which was daring at this time.



The Bosphorus Bridge in Norway

However, the Turkish Sultan Bajazet II, for whom the bridge was planned, rejected the building of this bridge over the Golden Horn. He declared that it was impossible to build such a structure. Thus the daring designs only remained as sketches! That is until 500 years after this, when the Norwegian Queen Sonja dedicated the Leonardo Bridge with its wood construction and its characteristic subarches and discharging arches in southern Norway.

■ The Swing Bridge:

In contrast to the Leonardo Bridge in Norway, the swing bridge was unfortunately never built. But, it did have the decisive advantage of being moveable. If big ships wanted to pass by it, then it could be swung to the side. It could, so to speak, be switched on and off. During wartime this would have been extremely useful. If attackers wanted invade the city on the other side of the river, then the bridge could simply be swung away. Too bad, this could have protected some cities against plundering raids. But you now have the chance to build the bridge that wasn't built at that time.

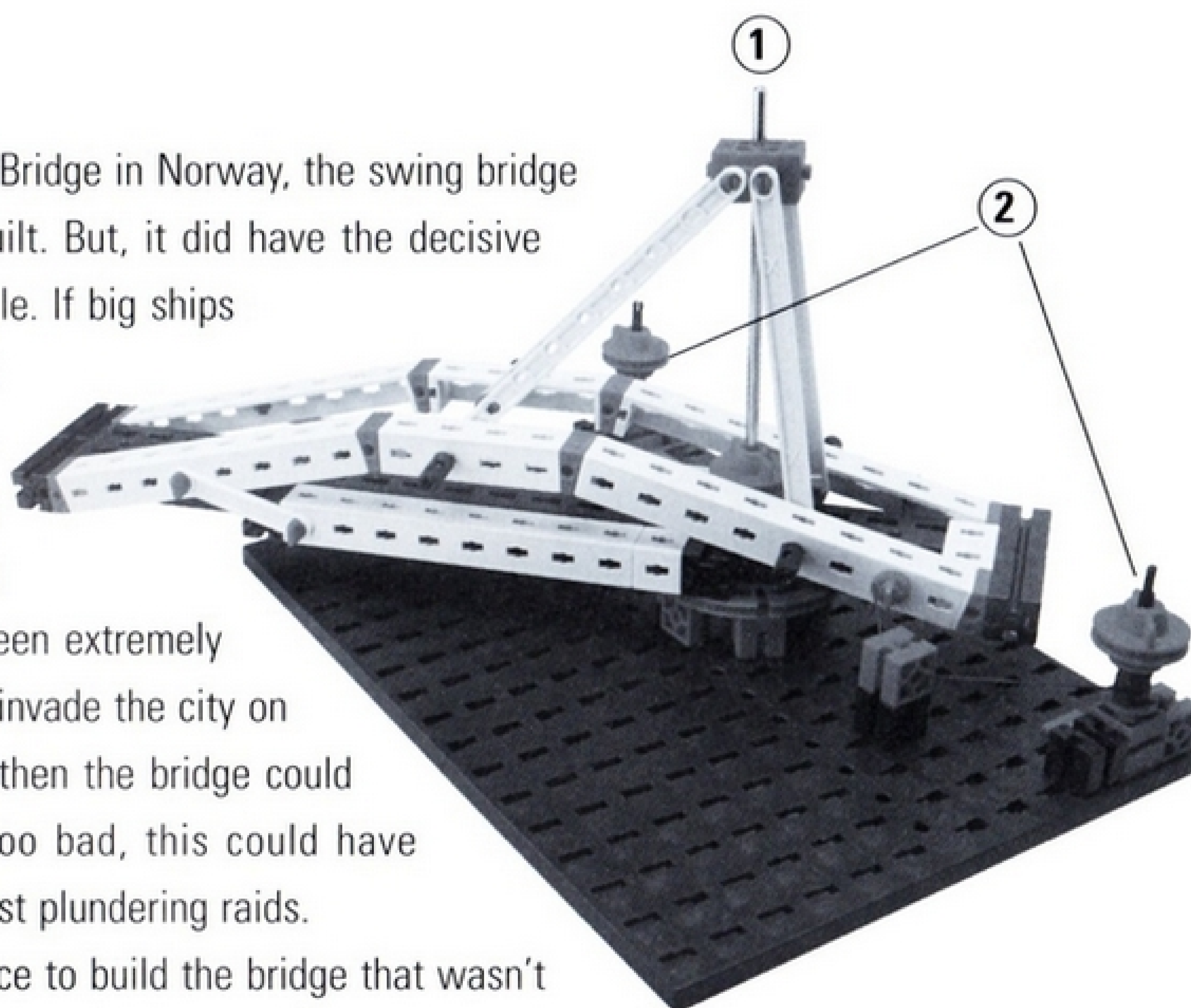

1. Suspension of the bridge and axis of rotation in one
2. The swinging in and the swinging out of the bridge is done using rope winches.

**Swing bridge**

**500 years later**

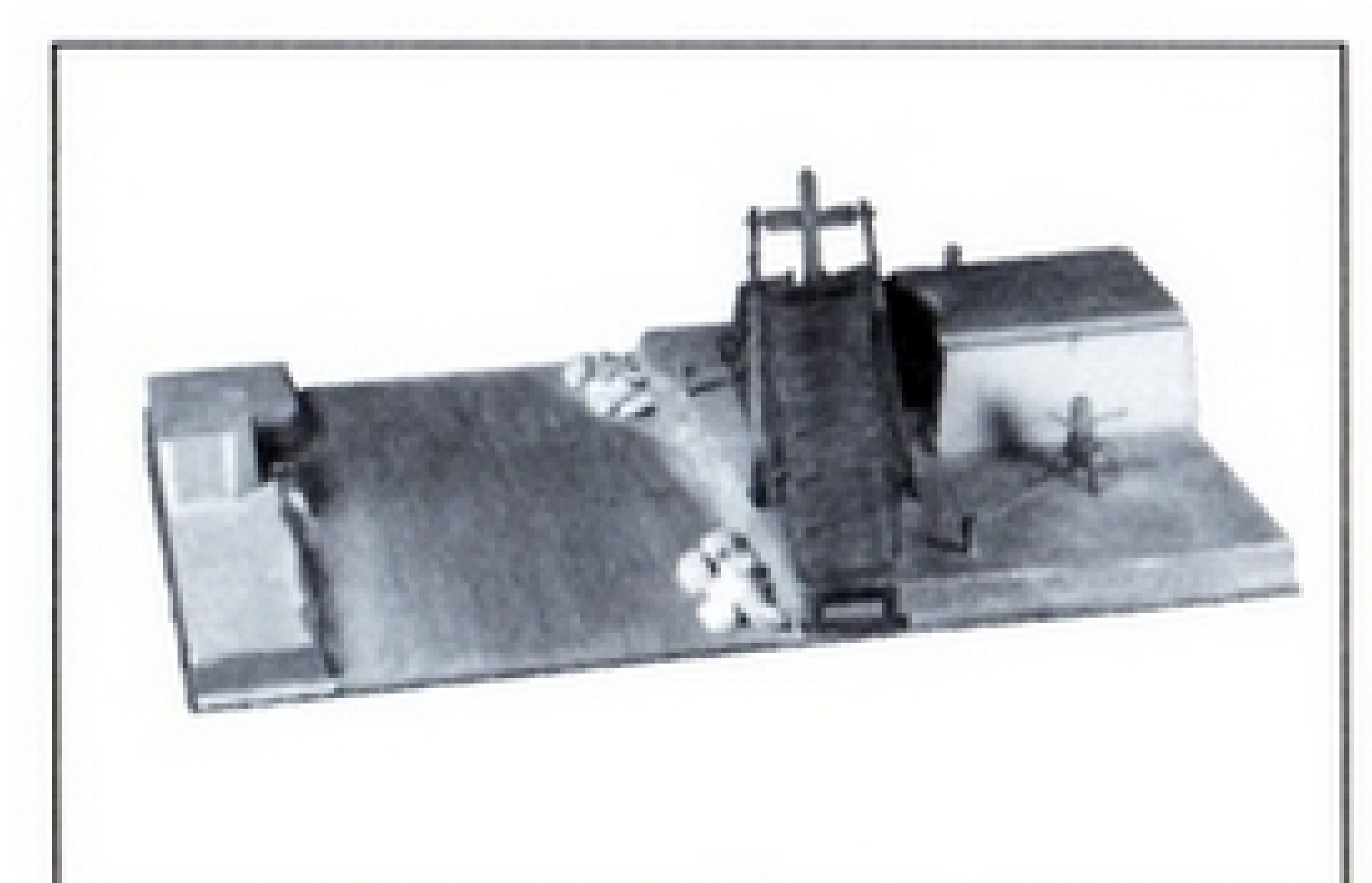
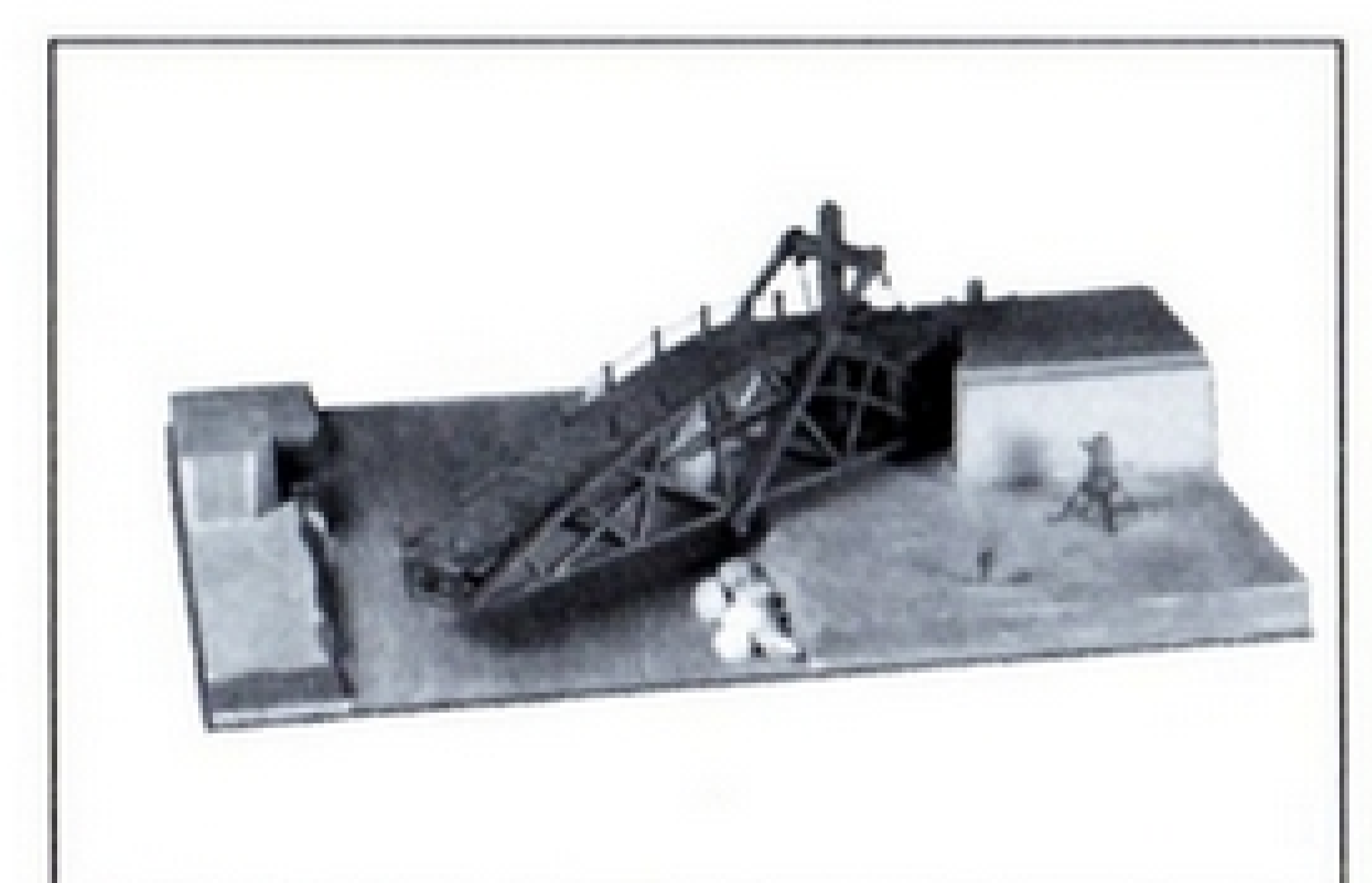
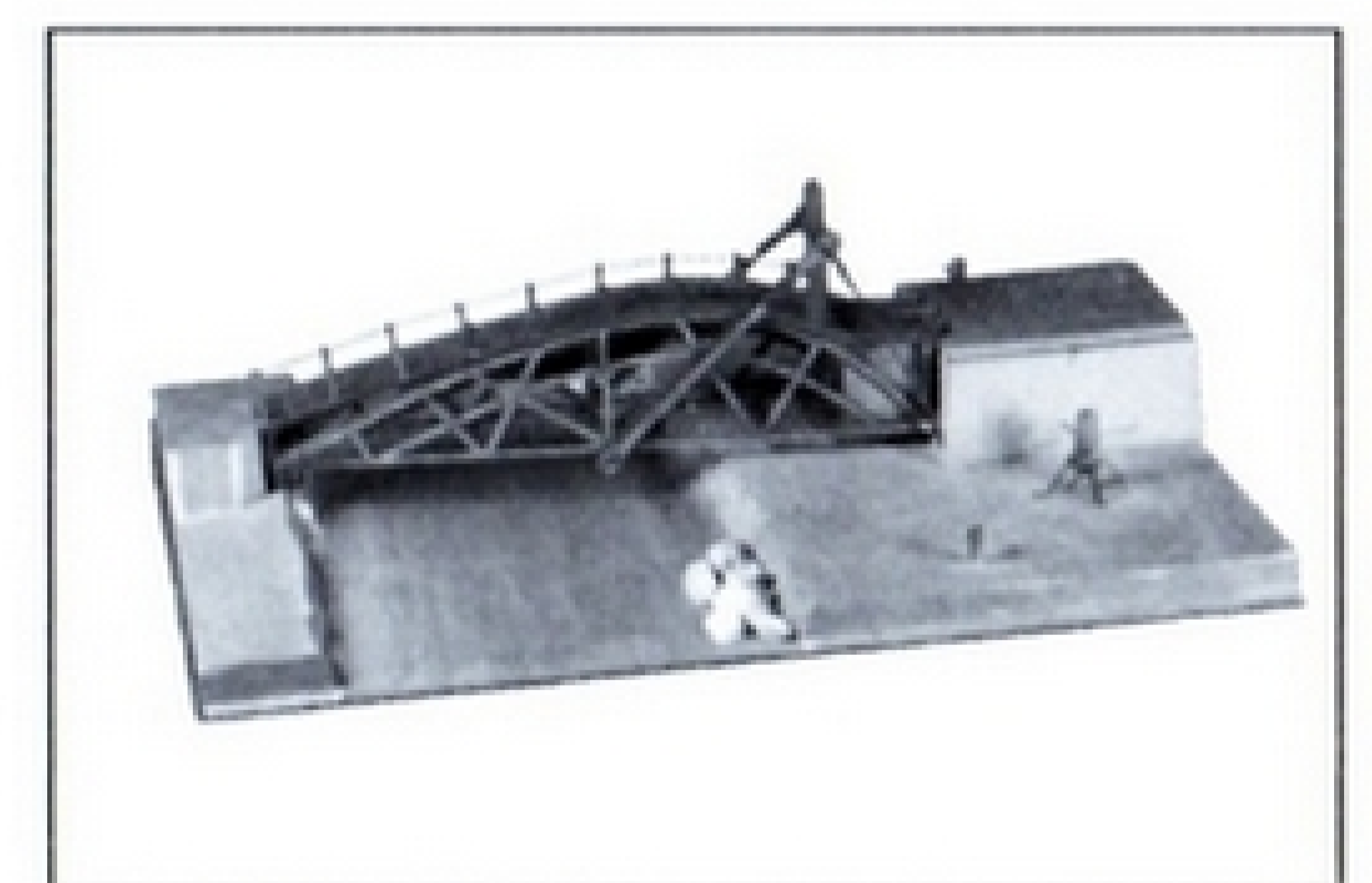





A series of horizontal dotted lines for writing, spanning the width of the page.



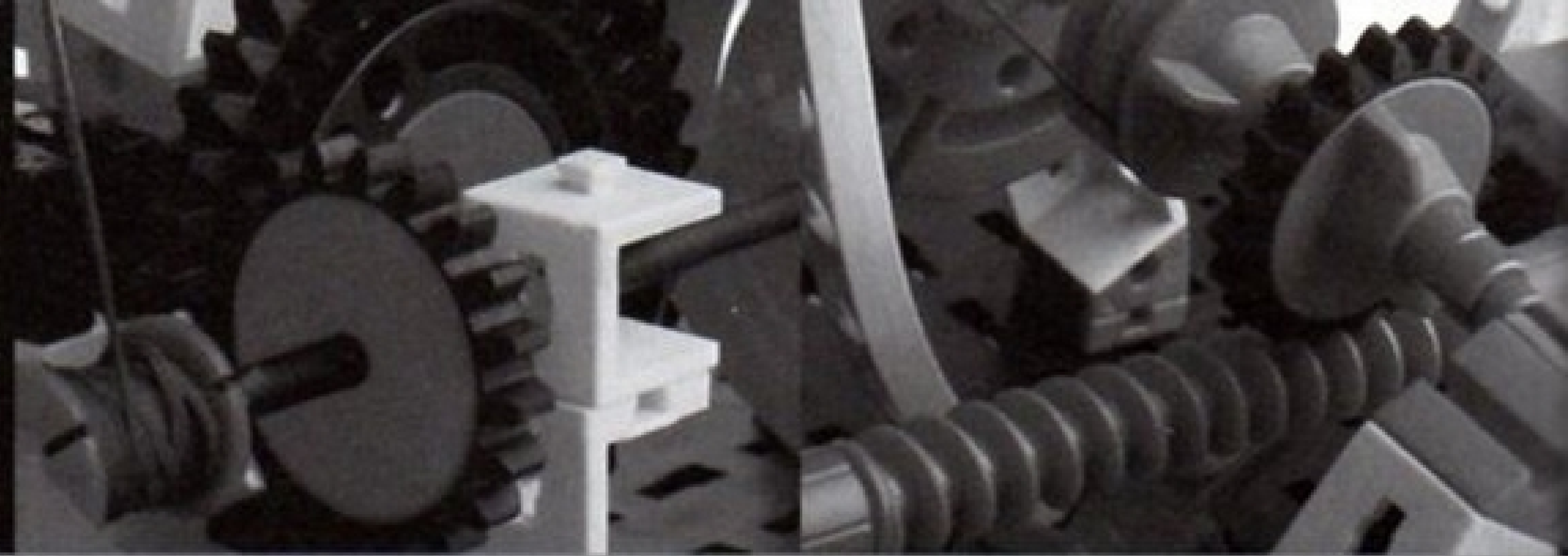

**fischertechnik** 

fischertechnik GmbH  
Weinhalde 14-18  
72178 Waldachtal  
Germany

Phone +49 74 43/12-43 69  
Fax +49 74 43/12-45 91

info@fischertechnik.de  
www.fischertechnik.de

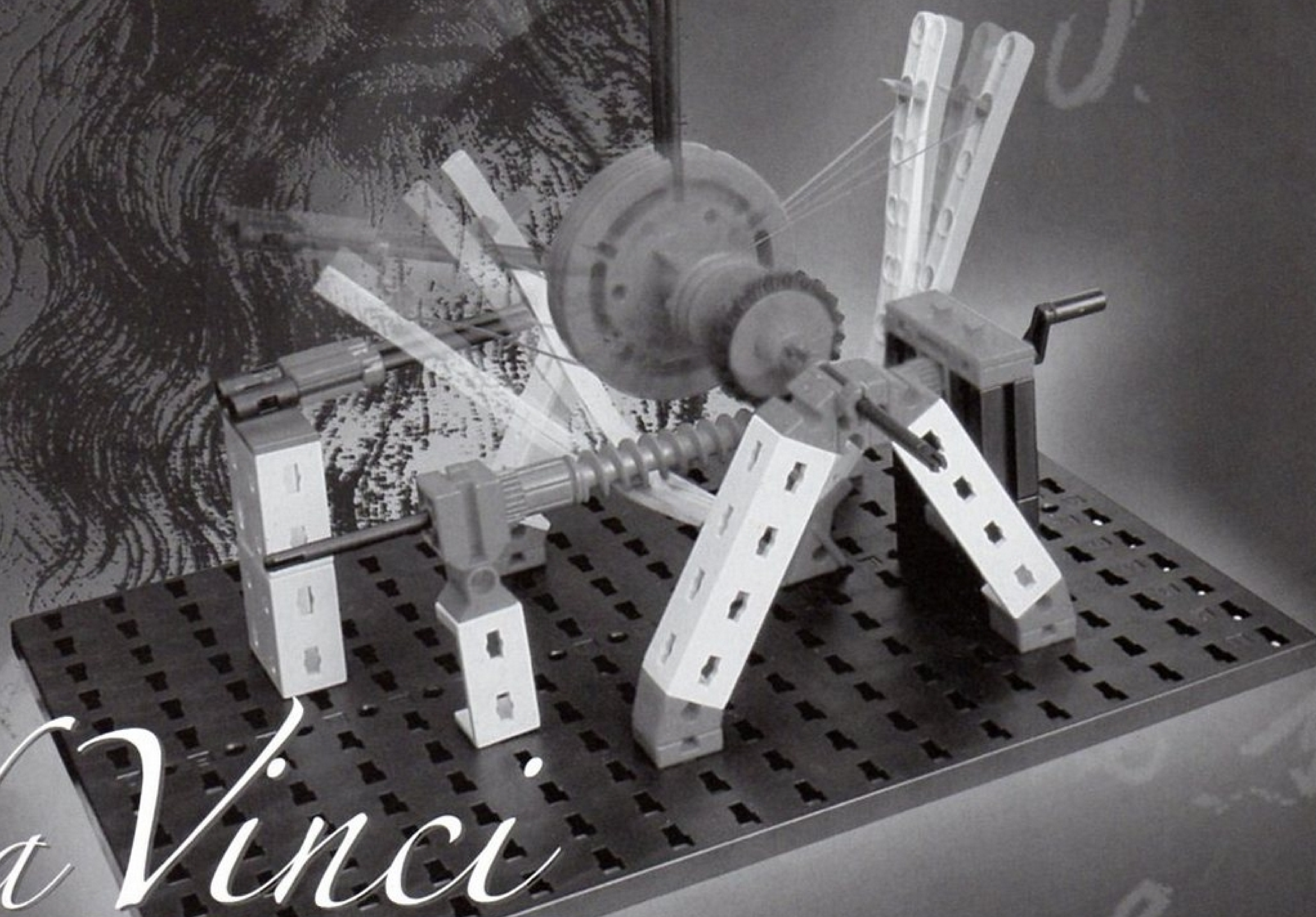

*da Vinci*  
**MACHINES**  
10 MODELS