

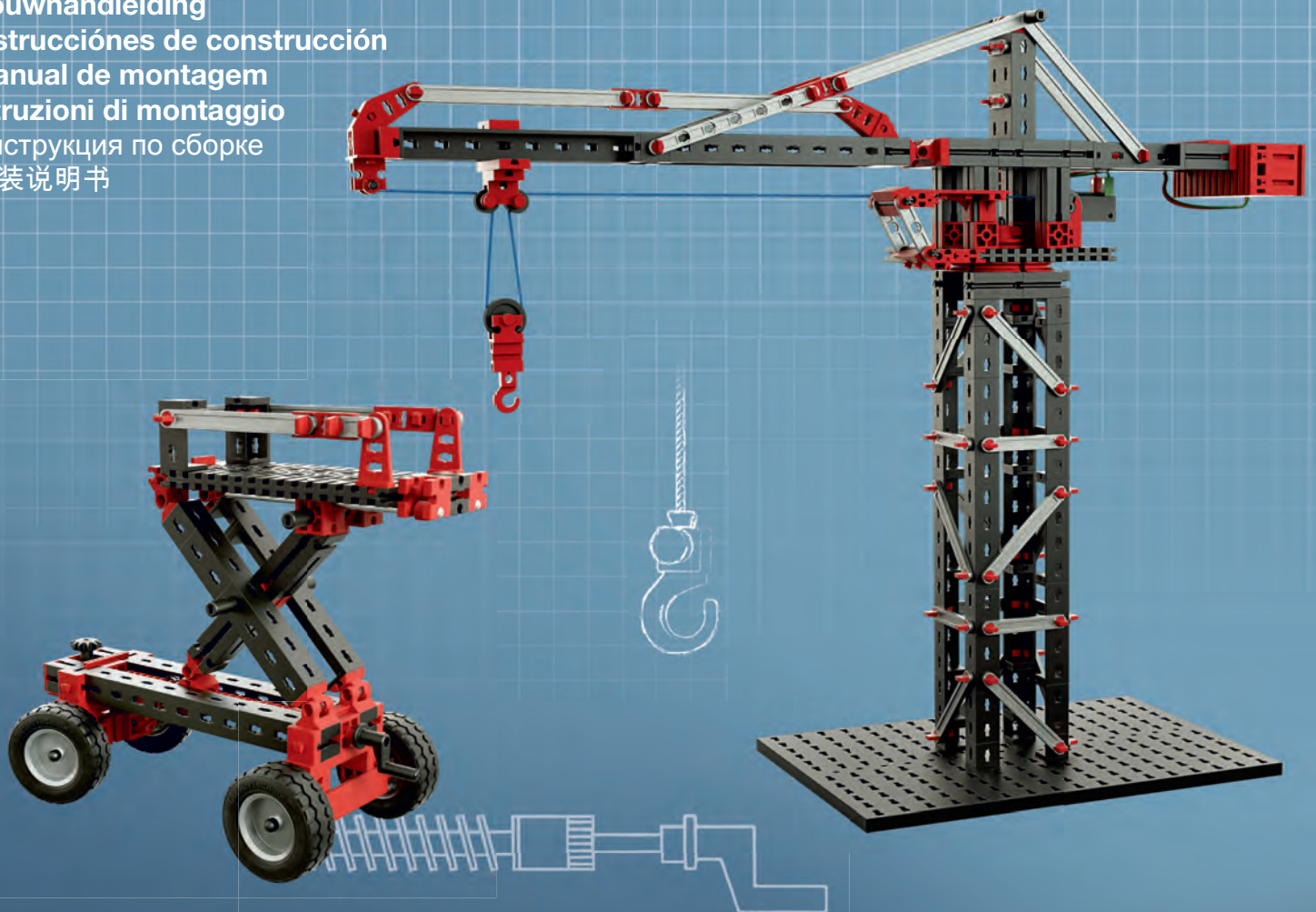

fischertechnik 

PROFI

Bauanleitung
Assembly instruction
Instructions de montage
Bouwhandleiding
Instrucciones de construcción
Manual de montagem
Istruzioni di montaggio
Инструкция по сборке
安装说明书



Didactic Information

www.fischertechnik-eLearning.com

free download ↓



**eLearning
Portal**

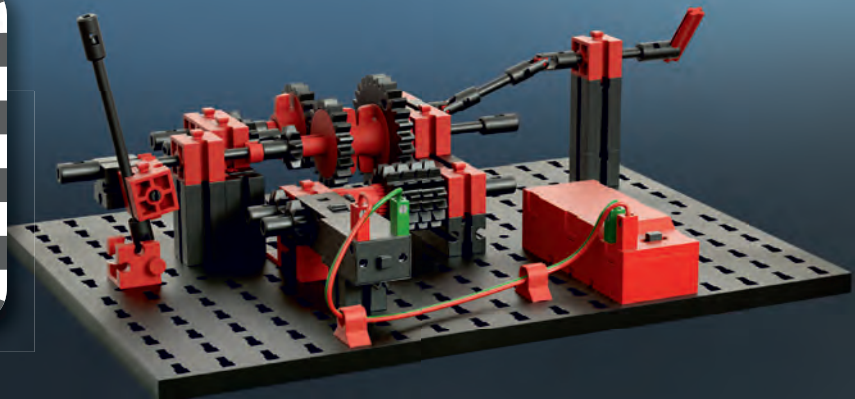

Mechanic & Static 2

30 MODELS



- Mit dem fischertechnik eLearning Portal geben wir Ihnen die Möglichkeit, noch mehr Hintergrundwissen zum Thema des Baukastens zu erhalten. Dabei stehen Ihnen didaktische Inhalte sowie technische Hintergrundinformationen, lehrreiche Begleitinformationen, Videos, Dokumentationen und vieles mehr zur Verfügung. Über **www.fischertechnik-elearning.com** gelangen Sie direkt zum eLearning Portal. Wir wünschen viel Spaß beim spielerischen Lernen und Entdecken mit fischertechnik!
- With the fischertechnik eLearning portal, we are giving you the opportunity to obtain even more background knowledge on the topic of the construction set. Didactic contents, technical background information, instructive accompanying information, videos, documentary films and much more are at your disposal. You can access the eLearning portal directly via **www.fischertechnik-elearning.com**. We hope that you have fun learning and discovering through play with fischertechnik!
- Avec le portail eLearning de fischertechnik, vous pouvez parfaire vos connaissances au sujet de la boîte de construction. Vous y trouverez des contenus didactiques et des informations techniques, d'autres informations complémentaires, des vidéos, de la documentation et bien plus encore. Cliquez sur **www.fischertechnik-elearning.com** pour accéder directement à notre portail. Nous vous souhaitons une découverte et un apprentissage pleins de plaisir avec fischertechnik !
- Met het fischertechnik eLearning portaal geven wij u de mogelijkheid, nog meer achtergrondkennis over het thema van het modulaire systeem te verkrijgen. Daarbij staan u didactieve inhoud alsmede technische achtergrondinformatie, educatieve begeleidende informatie, video's, documentaties en nog veel meer ter beschikking. Via **www.fischertechnik-elearning.com** komt u direct bij het eLearning portaal. Wij wensen veel plezier bij het spelenderwijs leren en ontdekken met fischertechnik!
- Con el portal de aprendizaje electrónico de fischertechnik le ofrecemos la oportunidad de obtener más conocimientos básicos sobre el tema de los módulos. De este modo, se pone a su disposición contenido didáctico, así como información básica técnica, información adicional instructiva, vídeos, documentos y muchas cosas más. A través de **www.fischertechnik-elearning.com** podrá acceder directamente al portal de aprendizaje electrónico. ¡Esperamos que se divierta aprendiendo y descubriendo jugando con fischertechnik!
- Com o portal de eLearning da fischertechnik damos lhe a possibilidade de obter ainda mais conhecimentos aprofundados sobre os kits de construção. Estão disponíveis conteúdos didáticos, informações técnicas de fundo, informações auxiliares úteis, vídeos, documentações e muito mais. Em **www.fischertechnik-elearning.com** pode aceder diretamente ao portal de eLearning. Esperamos que se divirta muito durante a aprendizagem e as descobertas com a fischertechnik!
- Con il portale eLearning di fischertechnik vi diamo la possibilità di accumulare maggiori informazioni di base sul tema delle scatole di montaggio. Vi troverete contenuti didattici e informazioni tecniche di background, informazioni accessorie molto istruttive, video, documenti e molto altro ancora. Tramite **www.fischertechnik-elearning.com** potete raggiungere direttamente il portale eLearning. Vi auguriamo buon divertimento nell'apprendere giocando e nella scoperta di fischertechnik!
- Обучающий Интернет-портал компании fischertechnik предлагает вам возможность получить больше базовых знаний по теме конструирования. В вашем распоряжении дидактические материалы, а также вводная техническая информация, поучительная сопроводительная информация, видеоматериалы, документация и многое другое. По ссылке **www.fischertechnik-elearning.com** вы попадаете прямо на обучающий Интернет-портал. Желаем вам приятно провести время в ходе игрового обучения и получения новых знаний с компанией fischertechnik!
- 通过 fischertechnik eLearning 电子学习门户网站，我们为您提供更多关于积木的背景知识。您可获得关于教学内容以及技术方面的背景知识、丰富的教学经验分享、视频、文档和其他实用内容。登陆 **www.fischertechnik-elearning.com** 访问我们的 elearning 门户网站。祝 fischertechnik 带给您更多学习和探索的乐趣！

Inhalt
Contents
Contenu

Einzelteilübersicht / Spare parts list / Liste des pièces détachées / Onderdelenoverzicht / Lista da piezas / Resumo de peça individual /
Singoli componenti / Перечень деталей / 零件概览 4

Montagetipps / Tips for assembly / Tuyaux pour le montage / Montagetips / Consejos para el montaje / "Dicas" para montagem /
Consigli per il montaggio / Советы по сборке / 装配建议 6



Schranke / Bar / Barrière / Slagboom / Barrera / Barriera /
Barreira / Шлагбаум / 栅栏 8

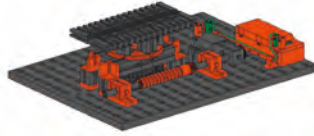

Drehtisch / Turntable / Plateau rotatif / Draaitafel /
Mesa giratoria / Mesa rotatória / Tavola rotante /
Поворотный стол / 转台 11



Kurbelgetriebe 1 / Crank gear 1 / Mécanisme à manivelle 1 /
Krukasoverbrenging 1 / Mecanismo de manivela 1 /
Engrenagem de manivela 1 / Ingranaggio a manovella 1 /
Кривошипный механизм 1 / 曲柄传动机构 1 15



Kurbelgetriebe 2 / Crank gear 2 / Mécanisme à manivelle 2 /
Krukasoverbrenging 2 / Mecanismo de manivela 2 /
Engrenagem de manivela 2 / Ingranaggio a manovella 2 /
Кривошипный механизм 2 / 曲柄传动机构 2 16



Schiefe Ebene mit Fahrzeug / Inclined plane with vehicle /
Plan incliné avec véhicule / Helling met voertuig / Plano
inclinado con vehículo / Rampa com veículo / Piano
inclinato con veicolo / Наклонный пандус с
автомобилем / 配备车辆的斜面 17



Fahrzeug 1 / Vehicle 1 / Véhicule 1 / Voertuig 1 /
Vehículo 1 / Veículo 1 / Veicolo 1 / Автомобиль 1 /
1号汽车 23



Fahrzeug 2 / Vehicle 2 / Véhicule 2 / Voertuig 2 /
Vehículo 2 / Veículo 2 / Veicolo 2 / Автомобиль 2 /
2号汽车 25



Fahrzeug 3 / Vehicle 3 / Véhicule 3 / Voertuig 3 /
Vehículo 3 / Veículo 3 / Veicolo 3 / Автомобиль 3 /
3号汽车 27



Fahrzeug 4 / Vehicle 4 / Véhicule 4 / Voertuig 4 /
Vehículo 4 / Veículo 4 / Veicolo 4 / Автомобиль 4 /
4号汽车 29



Bollerwagen / Handcart / Chariot à main / Bolderkar /
Carro / Carrinho de puxar / Carretto / Тележка /
儿童手拉车 31



Kardangelenk / Cardan joint / Joint de cardan / Cardano-
verbrenging / Articulación cardán / Junta universal / Giunto
cardanico / Карданный шарнир / 万向节 33

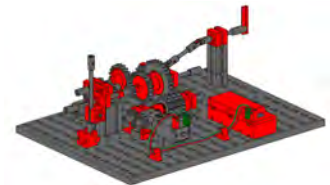

Schaltgetriebe / Gearbox / Mécanisme intermittent /
Schakeloverbrenging / Cambio de velocidades / Caixa de
câmbio / Cambio meccanico / Коробка передач /
变速器 35

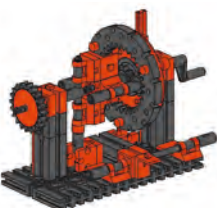

Planetengetriebe / Planetary gear / Engrenage pla-
nétaire / Planeetwieloverbrenging / Engranaje plane-
tario / Engrenagem planetária / Rotismo epicicloidal /
Планетарный редуктор / 行星齿轮机构 40



Kegelradgetriebe / Bevel gear / Engrenage à pignon
conique / Conische tandwieloverbrenging / Engranaje de
ruedas cónicas / Engrenagem cônica / Ingranaggio conico /
Конический редуктор / 锥齿轮传动机构 43

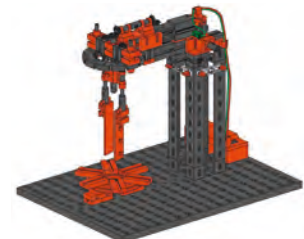

Küchenmaschine / Kitchen appliance / Robot ménager /
Keukenmachine / Máquina de cocina / Máquinas de cozinha
/ Robot da cucina / Кухонный комбайн /
电动厨具 44

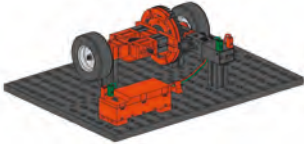

Differentialgetriebe / Differential gear / Engrenage différentiel / Differentieel / Engranaje diferencial / Transmissão diferencial / Differenziale / Дифференциал / 差速机构 49



Scherenhubtisch mit Lenkung / Scissor lift table with steering system / Table élévatrice à ciseaux avec renvoi de direction / Schaarheftafel met stuur / Mesa elevadora de tijera con dirección / Mesa elevatória de tesouras com direção / Elevatore a pantografo con sterzo / Ножничный подъёмный стол на тележке / 带转向机构的剪式升降台 52

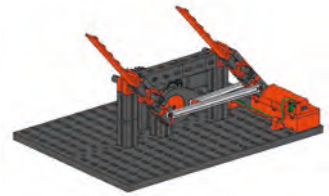

Scheibenwischer / Windshield wiper / Essuie-glace / Ruitenwischer / Limpiaparabrisas / Para-brisas / Tergicristallo / Стеклоочистители / 刮雨器 56



Viergelenkette / Four-bar chain / Chaîne cinématique à quatre joints articulés / Vierscharniersmechanisme / Mecanismo de cuatro articulaciones / Corrente de quatro articulações / Catena a quattro articolazioni / Четырехзвенный шарнирный механизм / 四活节链 60

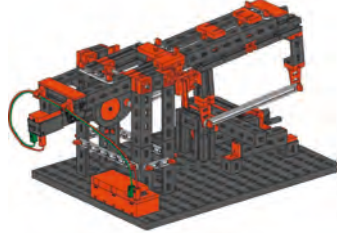

Bügeläge / Power hacksaw machine / Scie à archet / Beugelzaag / Sierra de arco / Serra de arco / Seghetto ad arco / Ножовка / 弓锯 61

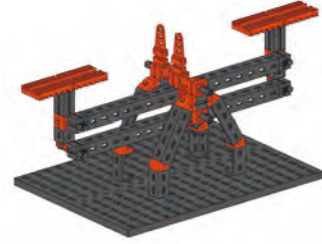

Balkenwaage / Beam and scales / Crochet-basculé / Balansweegschaal / Balanza de brazos / Balança de pratos / Bilancia a braccio / Весы с коромыслом / 天平 68

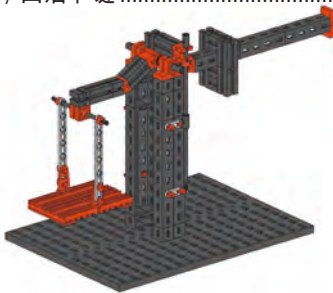

Waage mit Laufgewicht / Scales with sliding weight / Balance à poids mobile / Weegschaal met schuifgewicht / Balanza con pesa corrediza / Balança com peso cursor / Bilancia con cursore / Весы с подвижным грузом / 带滑动秤锤的天平 72

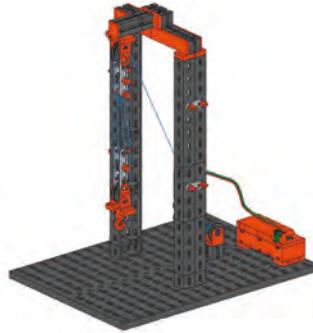

Flaschenzug / Lifting tackle / Palan / Takel / Polipasto / Talha / Paranco / Таль / 滑轮组 77



Tisch / Table / Table / Tafel / Mesa / Mesa / Tavola / Стол / 工作台 xx



Bockleiter / Double ladder / Echelle double / Trapladder / Escalera de tijera / Escada de cavalete / Scala a libro / Стремянка / 人字梯 90



Balkenbrücke / Girder Bridge / Pont à poutres droites / Balkenbrug / Puente de vigas / Ponte de travessa / Ponte a trave / Балочный мост / 梁式桥 93

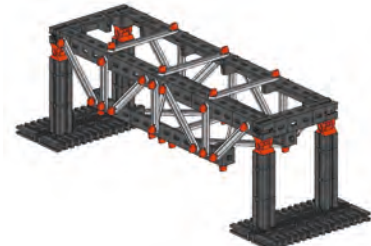

Brücke mit Unterzug / Bridge with Underbeam / Pont avec solive transversale / Brug met onderlagbalken / Puente con viga maestra / Ponte com viga de sustentação inferior / Ponte con trave inferiore / Мост с нижней рамой / 带下托梁的桥 95



Brücke mit Oberzug / Bridge with Upperbeam / Pont à membrure supérieure transversale / Brug met bovenslagbalken / Puente con viga testera / Ponte com viga de sustentação superior / Ponte con trave superiore / Мост с верхней рамой / 带上托梁的桥 97



Schrägseilbrücke / Cable-stayed bridge / Pont à haubans / Tuibrug / Puente atirantado / Ponte estaiada / Ponte con funi di sospensione / Вантовый мост / 斜拉桥 101





















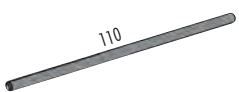









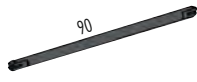

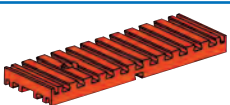















































Kran / Crane / Grue / Kraan / Grúa / Guindaste / Gru / Кран / 起重机 105

Einzelteilübersicht
Spare parts list
Liste des pièces détachées

Onderdelenoverzicht
Lista da piezas
Resumo de peça individual

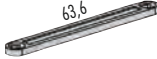
Singoli componenti
Перечень деталей
零件概览

	31 010 4 x		31 690 5 x		35 031 3 x		35 694 1 x
	31 011 4 x		31 843 2 x		35 033 2 x		35 695 4 x
	31 019 1 x		31 848 3 x		35 049 6 x		35 797 2 x
	31 021 2 x		31 915 1 x		35 061 2 x		35 945 6 x
	31 022 1 x		31 916 1 x		35 062 2 x		35 969 2 x
	31 031 2 x		31 982 13 x		35 063 4 x		35 971 4 x
	31 058 3 x		31 983 2 x		35 064 2 x		35 972 2 x
	31 060 10 x		32 064 11 x		35 065 3 x		35 998 2 x
	31 061 3 x		32 085 1 x		35 066 2 x		36 227 2 x
	31 078 1 x		32 859 2 x		35 069 1 x		36 248 38 x
	31 082 1 x		32 869 1 x		35 070 1 x		36 264 1 x
	31 336 2 x		32 870 4 x		35 073 6 x		36 293 4 x
	31 337 2 x		32 879 13 x		35 087 3 x		36 323 60 x
	31 426 5 x		32 881 10 x		35 088 1 x		36 324 6 x
	31 436 11 x		32 882 4 x		35 113 1 x		36 334 3 x
	31 597 6 x		32 913 4 x		35 129 2 x		36 443 1 x
	31 667 4 x		32 985 1 x		35 466 1 x		36 819 7 x

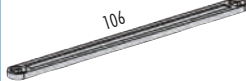
	36 920 8 x		37 679 7 x		38 260 4 x		153 669 2 x
	36 921 16 x		37 858 1 x		38 414 2 x		156 105 4 x
	36 922 5 x		37 925 1 x		38 423 2 x		160 541 4 x
	36 950 7 x		37 926 3 x		38 428 5 x		160 542 8 x
	36 977 1 x		38 225 1 x		38 464 4 x		160 543 12 x
	37 237 12 x		38 240 4 x		38 472 1 x		160 544 2 x
	37 238 2 x		38 242 1 x		68 535 1 x		160 545 4 x
	37 468 8 x		38 245 2 x		116 913 4 x		160 546 4 x
	37 527 1 x		38 246 3 x		135 719 1 x		160 547 12 x
	37 636 2 x		38 258 2 x		137 096 1 x		160 548 12 x

Montagetipps
Tips for assembly
Tuyaux pour le montage

Montagetips
Consejos para el montaje
"Dicas" para montagem

Consigli per il montaggio
Советы по сборке
装配建议

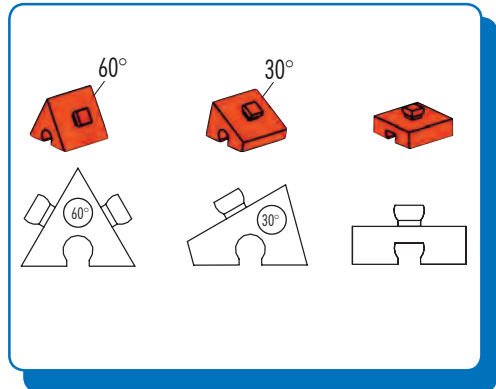
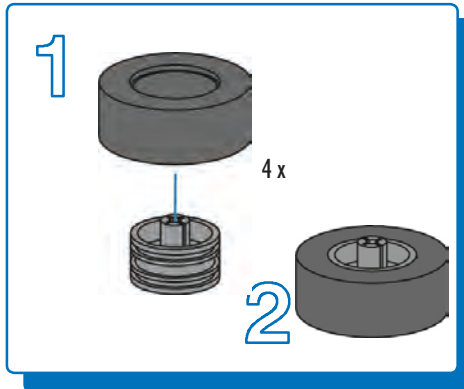
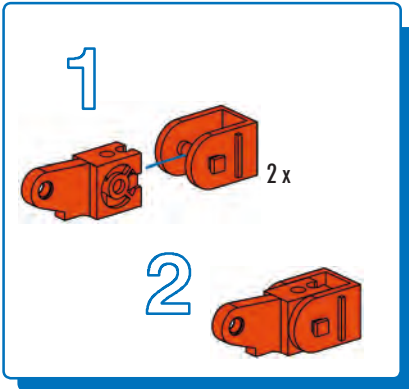
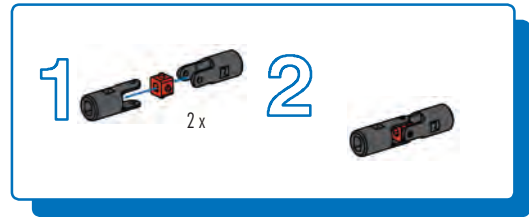
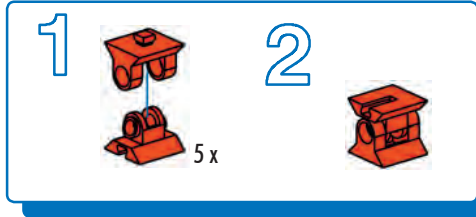
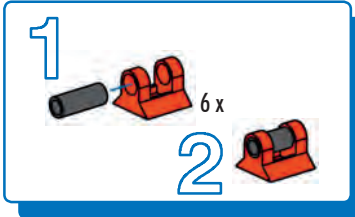

Kabel und Stecker
Plugs and cables
Fiches et des câbles

Stekkers en cables
Enchufes en cables
Cabos e contatos

Cavi e connettori
Провода и штекеры
电缆和插头

0 3 cm

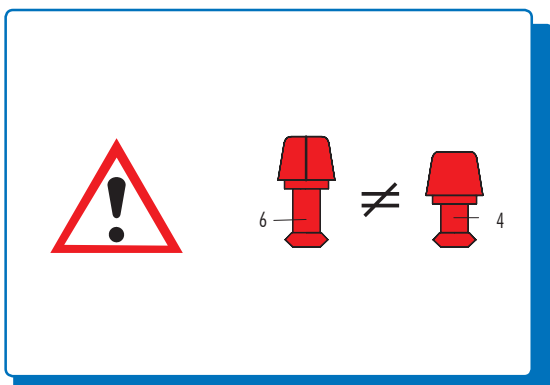
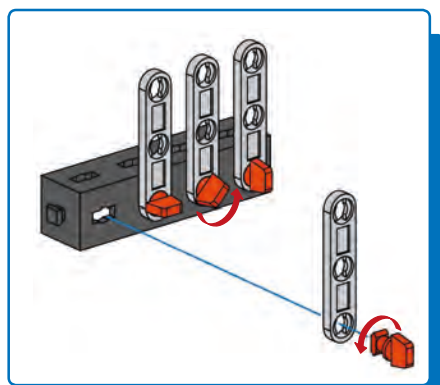
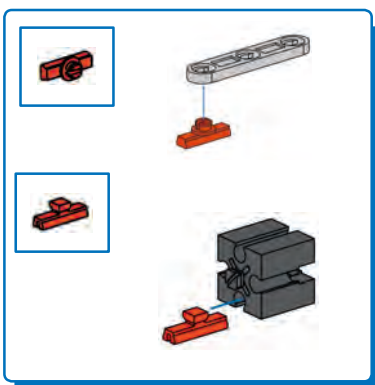

Sicherheitshinweise
Safety Information
Consignes de sécurité

Veiligheidsrichtlijnen
Indicaciones de seguridad
Observações sobre segurança

Informazioni per la sicurezza
Указания по технике безопасности
安全指南

- Alle Einzelteile, insbesondere bewegliche Teile sind falls notwendig zu warten und zu reinigen.
- All components, especially moving parts, should be maintained and cleaned as necessary.
- Toutes les pièces détachées et en particulier les pièces mobiles, sont, si nécessaire, à entretenir et à nettoyer.
- Alle onderdelen, vooral de bewegende delen, kunnen, indien noodzakelijk, onderhouden en gereinigd worden.
- Es necesario limpiar y mantener en buen estado todas las diferentes piezas - especialmente las piezas móviles.
- Caso necessário, todas as peças individuais, especialmente peças móveis, tem que ser submetidas à manutenção e ser limpas.
- Se necessario, tutti i singoli componenti, soprattutto le parti mobili, si devono eventualmente sottoporre a manutenzione e pulizia.
- Все детали, особенно подвижные, требуют ухода и чистки.
- 必要时应保养和清洁所有零件，尤指运动部件。

Sicherheitshinweise Safety Information Consignes de sécurité

Veiligheidsrichtlijnen Indicaciones de seguridad Observações sobre segurança

Informazioni per la sicurezza Указания по технике безопасности 安全指南

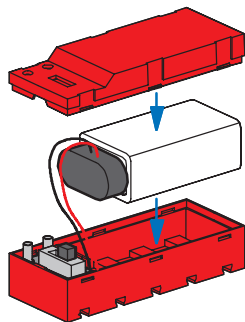

Batterie ist nicht Inhalt der Packung
Battery not included
Batterie non comprise
De batterij wordt niet meegeleverd
La batería no está incluida en el suministro
A bateria não é o conteúdo da embalagem
La batteria non è inclusa nella confezione
Батарея в комплект не входит
包装中不含电池

1 Batterie 9Volt-Block Alkaline oder 1 NiMH-Akku 9V

- Nicht wiederaufladbare Batterien dürfen nicht geladen werden
- Aufladbare Batterien dürfen nur von Erwachsenen geladen werden
- Aufladbare Batterien sind aus dem Batteriehalter herauszunehmen, bevor sie geladen werden.
- Batterien müssen mit der richtigen Polarität eingelegt werden.
- Leere Batterien müssen aus dem Spielzeug herausgenommen werden
- Die Anschlussklemmen dürfen nicht kurzgeschlossen werden.
- Verbrauchte Batterien dem Sondermüll zuführen.
- Drähte nicht in Steckdose einführen!
- Ladegerät regelmäßig auf Schäden überprüfen. Bei einem Schaden darf das Ladegerät bis zur vollständigen Reparatur nicht mehr verwendet werden.

9V rechargeable battery or 9 V alkaline dry cell

- Do not attempt to charge NON-rechargeable batteries.
- Rechargeable batteries are only to be charged by adults.
- Take rechargeable batteries out of the battery tray before charging them.
- Insert batteries with the correct polarity.
- Remove dead batteries from the toy.
- Do not short circuit the connecting terminals!
- Discard spent dry cells at special waste disposal centre.
- Do not insert the wires into an outlet!
- Regularly inspect battery charger for damage. If the battery charger has been damaged, it should not be used further until fully repaired.

pile 9V ou accu 9V

- Il est interdit de recharger des piles qui ne sont pas des accumulateurs
- Le chargement des accumulateurs doit toujours se faire par des adultes
- Retirer les accumulateurs du support de pile avant de les recharger.
- Veiller à la polarité correcte lors de la mise en place des piles.
- Retirer impérativement les piles ou accumulateurs vides du jouet.
- Il est interdit de court-circuiter les bornes de raccordement.
- Jeter les piles usagées dans un conteneur spécial réservé à cet effet.
- Ne pas introduire les fils dans une prise !
- Contrôlez régulièrement le chargeur en vue d'éventuelles détériorations
- En cas de détérioration, il est interdit d'utiliser le chargeur jusqu'à ce qu'il ait été intégralement réparé

alkaline batterij of oplaadbare batterij (9Volt)

- Niet-oplaadbare batterijen mogen niet worden opgeladen.
- Oplaadbare batterijen mogen uitsluitend door volwassenen worden opgeladen.
- Oplaadbare batterijen moeten uit de batterijhouder worden verwijderd, voordat deze worden opgeladen.
- De batterijen moeten met de juiste polariteit worden geplaatst.
- Lege batterijen moeten uit het speelgoed worden verwijderd.
- De aansluitklemmen mogen niet worden kortgesloten.
- Afgevoerd gebruikte batterijen bij het klein chemisch afval (KCA).
- Geen draden in de contactdoos steken!
- Laadtoestel regelmatig controleren op schade. Bij schade mag het laadtoestel niet meer gebruikt worden tot het volledig hersteld is.

pila alcalina bloque de 9 Voltios o acumulador NiMH- de 9 Voltios

- Las pilas no recargables no pueden ser cargadas
- Las pilas recargables sólo pueden ser cargadas por un adulto
- Las pilas recargables deben ser extraídas del compartimiento de pilas antes de que sean cargadas.
- Las pilas deben ser colocadas con la polaridad correcta.
- Las pilas descargadas deben ser extraídas del juguete
- Los bornes de conexión no pueden ser puestos en cortocircuito.
- Retirar las baterías viejas, desechándolas en un depósito de basuras especiales.
- No introducir hilos en la toma de corriente!
- Comprobar con regularidad si el cargador presenta daños. En caso de presentar daños, el cargador no debe volver a ser utilizado hasta que esté completamente reparado.

Bateria alcalina de bloco de 9 V ou acumulador NiMH- de 9 V

- Pilhas não recarregáveis não devem ser novamente carregadas.
- Pilhas recarregáveis somente devem ser recarregadas por adultos.
- Pilhas recarregáveis devem ser retiradas do compartimento de pilhas antes de serem carregadas.
- As pilhas devem ser colocadas com a polaridade correta.
- As pilhas descarregadas devem ser retiradas do brinquedo.
- Os terminais de conexão não devem ser curto-circuitados.
- Eliminar as baterias esgotadas como desperdício perigoso
- Nunca introduzir fios na tomada!
- Verificar regularmente se o carregador apresenta danos. Em caso de dano, o carregador não deverá ser utilizado enquanto não estiver plenamente consertado.

1 batteria alcalina da 9 V o 1 batteria NiMH- ricaricabile da 9V

- Le batterie non ricaricabili non devono essere ricaricate
- Le batterie ricaricabili devono essere ricaricate da persone adulte
- Le batterie ricaricabili si devono estrarre dal supporto prima di ricaricarle.
- Le batterie si devono inserire rispettando la polarità.
- Togliere le batterie dal giocattolo quando sono scariche
- I morsetti di allacciamento non devono essere cortocircuitati.
- Smaltire le batterie usate negli appositi contenitori per la raccolta differenziata.
- Non inserire i fili nella presa elettrica.
- Controllare periodicamente se il caricabatterie presenta dei danni. In caso di danni, il caricabatterie non deve più essere utilizzato fino alla riparazione.

1 алкалиновая батарейка на 9 В или 1 никель-кадмиевый аккумулятор, 9 В

- Не пытайтесь заряжать перезаряжаемые батарейки.
- Зарядку перезаряжаемых аккумуляторов разрешается выполнять только взрослым.
- Перед зарядкой перезаряжаемых аккумуляторов извлеките их из аккумуляторного отсека.
- При установке аккумуляторов на место соблюдайте полярность.
- Разряженные батарейки необходимо извлечь из игрушки.
- Не замыкайте накоротко соединительные клеммы.
- Использованные батареи утилизировать как спецотходы.
- Не вставляйте в розетку провода!
- Регулярно проверяйте зарядное устройство на отсутствие повреждений. При наличии повреждений использовать зарядное устройство до выполнения его полного ремонта не разрешается.

1 个 9V 的碱性方电池或 1 个 9V 的 NiMH- 蓄电池

- 不得给非充电电池充电
- 只允许由成年人给充电电池充电
- 在充电前必须将充电电池从电池夹中取出。
- 必须按照正负极正确放入电池。
- 必须从玩具中取出没有电的电池
- 接线柱不允许被短路。
- 用完了的电池应作为特种垃圾处理。
- 禁止将金属丝插入插座！
- 经常检查充电器是否有损坏情况。如果充电器有损，直到完全修好为止不可以再使用。

Das Spielzeug darf nur mit einer der folgenden fischertechnik Energiequellen benutzt werden:
Art-Nr.: 135719 Batteriehalter 9V oder Art.-Nr.: 35537 Accu Pack 8,4V.

The toy may only be used with one of the following fischertechnik energy sources:
Art No.: 135719 battery tray 9V or Art No.: 35537 Accu Pack 8.4V.

L'utilisation de ce jouet n'est permis qu'avec l'une des sources d'énergie fischertechnik suivantes:
Art. n° : 135719 support de pile 9 volts ou Art. n° : 35537 pack d'accumulateurs 8,4 volts.

Het speelgoed mag uitsluitend met een van de volgende fischertechnik energiebronnen worden gebruikt: art.nr.: 135719 batterijhouder 9V of art.nr.: 35537 accupack 8,4V

El juguete se debe utilizar únicamente con una de las siguientes fuentes de energía:
Art. No. 135719 soporte de pila de 9V o Art. No. 35537 paquete acumulador de 8,4V.

O brinquedo somente pode ser utilizado com uma das seguintes fontes de energia da fischertechnik: art. n°: 135719 Suporte de bateria de 9 V ou art. n°: 35537 Bloco de bateria de 8,4V.

Questo giocattolo può essere utilizzato solo con le seguenti fonti di energia fischertechnik: cod. prod.: 135719 portabatteria da 9V oppure cod. prod.: 35537 confezione batterie da 8,4V.

Игрушку можно использовать только с одним из следующих источников энергии от fischertechnik: арт. №: 135719 держатель батарейки 9В или арт. №: 35537 Accu Pack 8,4В

该玩具只允许使用如下的慧鱼 (fischertechnik) 能量源：商品号：135719，9V 电池夹，或者商品号：35537，8.4V 电池套件 (Accu Pack)

Achtung! Verletzungsgefahr an Bauteilen mit funktionsbedingten scharfen Kanten und Spitzen!

Caution! Be careful not to hurt yourself on components with sharp or pointed edges!

Attention! Risque de blessure sur les éléments comportant des arêtes et o pointes vives indispensables au bon fonctionnement!

Let op! U kunt zich bezeren aan bouwstenen met sjerpe randen of punten!

Attenzione! Esiste il pericolo di lesione con i pezzi di costruzione che hanno bordi e punte spigolosi necessari per la funzionalità del pezzo!

Atenção! Perigo de ferimentos em peças componentes com cantos vivos e pontas obrigatórias para o funcionamento !

Attenzione! Pericolo di lesioni dovute a componenti con spigoli vivi e punte per motivi funzionali!

Будьте осторожны! Об острые края деталей и и наконечники можно порезаться!

注意！因功能需要而带有锋利的棱边和尖角的部件可能会带来受伤危险！

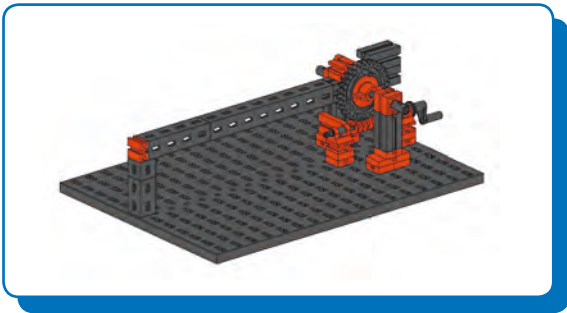

Schranke
Bar
Barrière

Slagboom
Barrera
Barriera

Barreira
Шлагбаум
栅栏

1

1 x

6 x

4 x

1 x

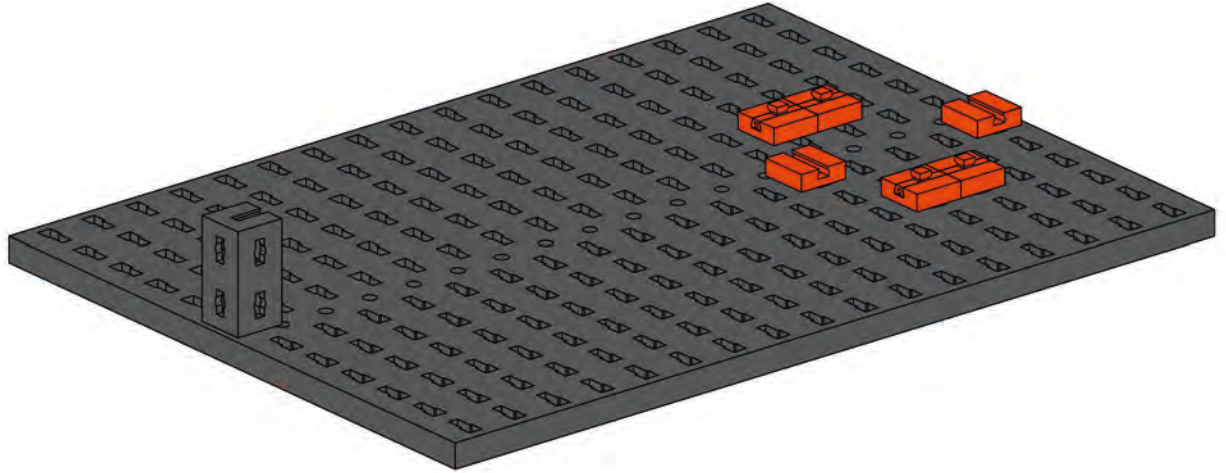

2

1 x

1 x

2 x

1 x

2 x

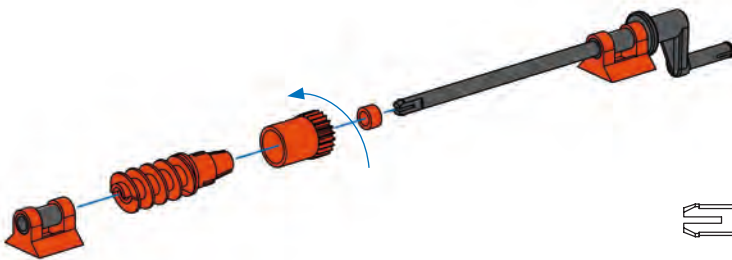
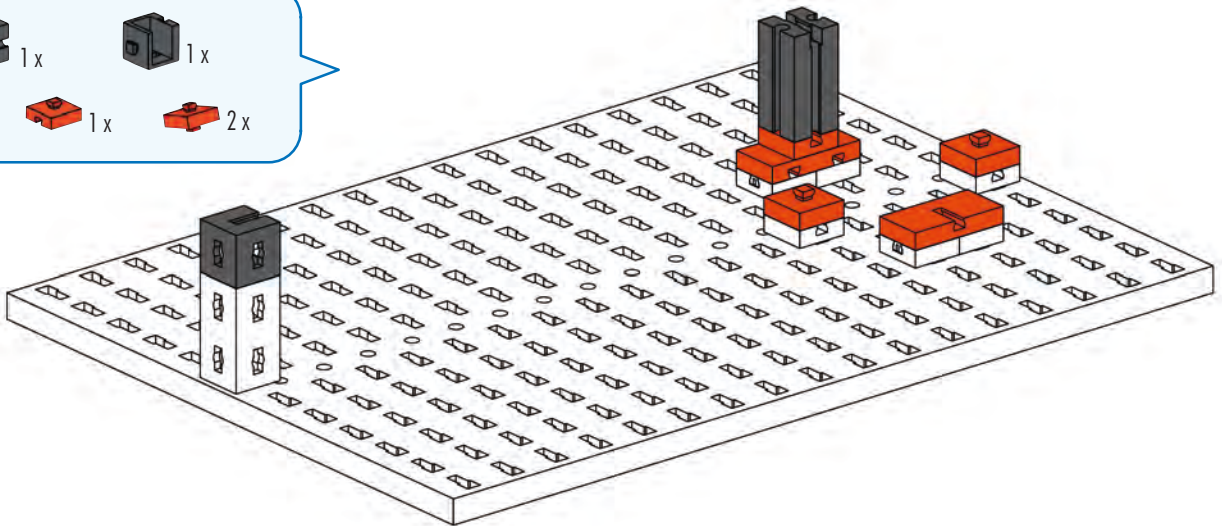

3

90

1 x

2 x

1 x



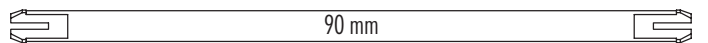

1 x

1 x

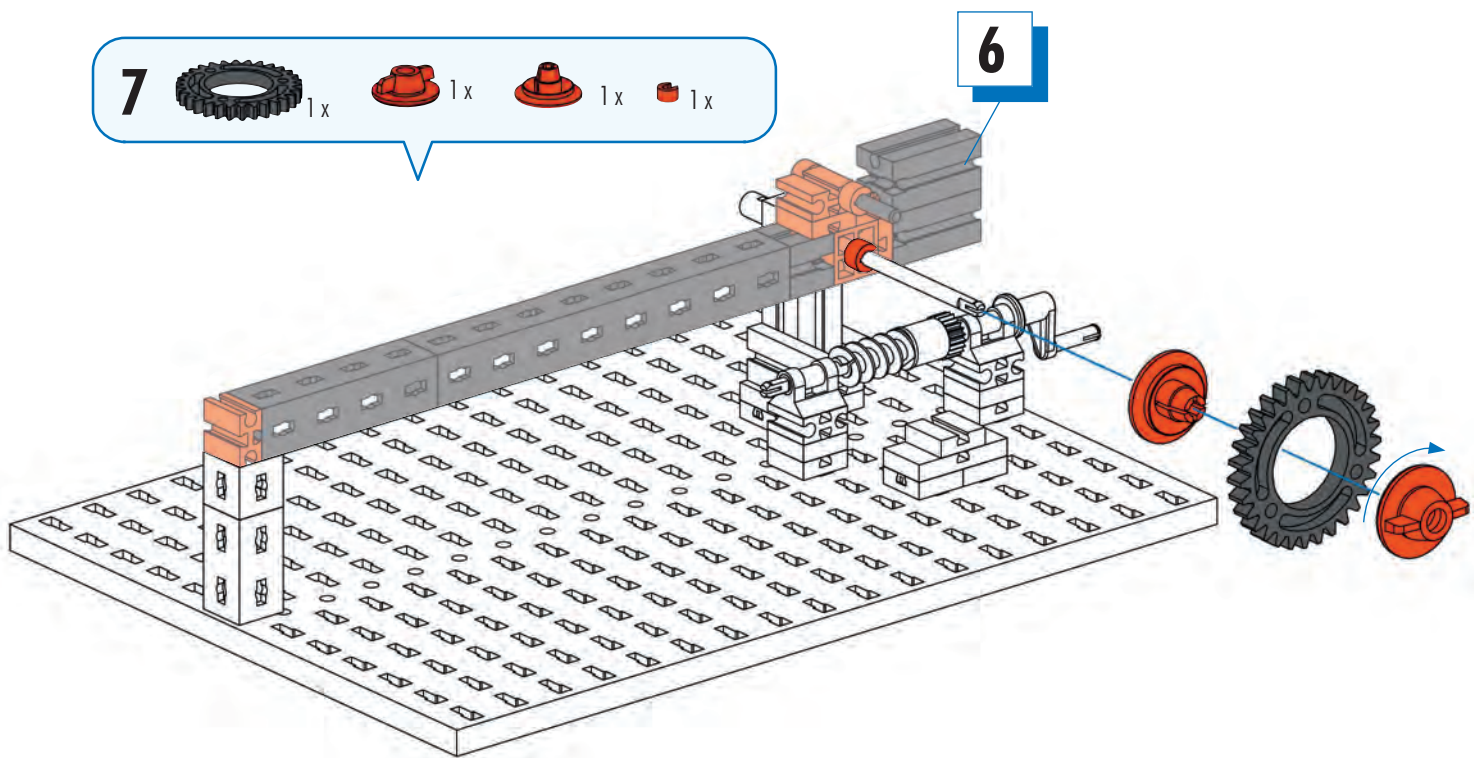
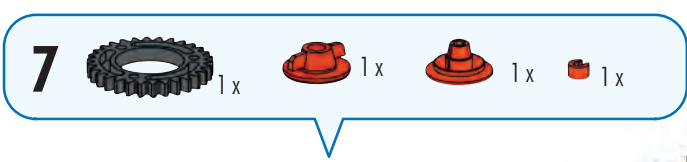
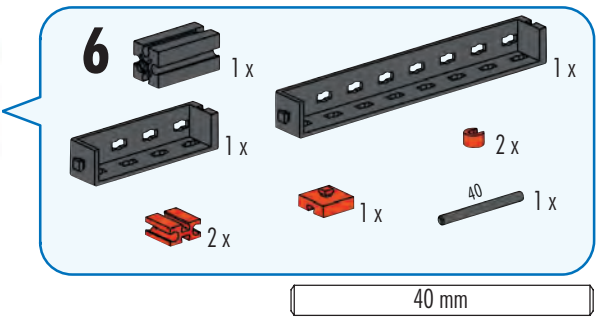
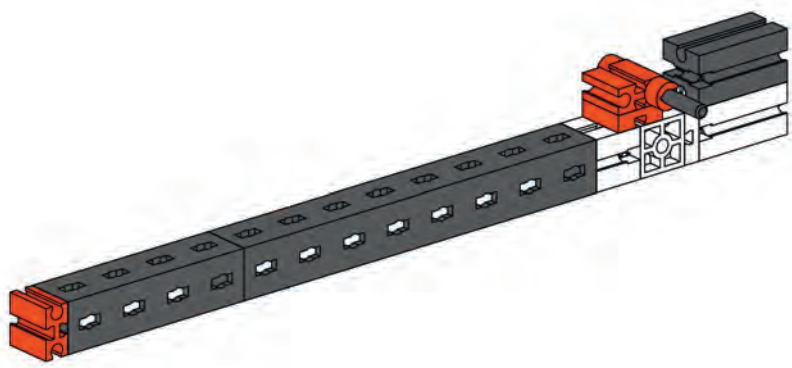
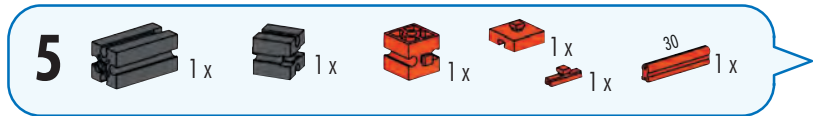
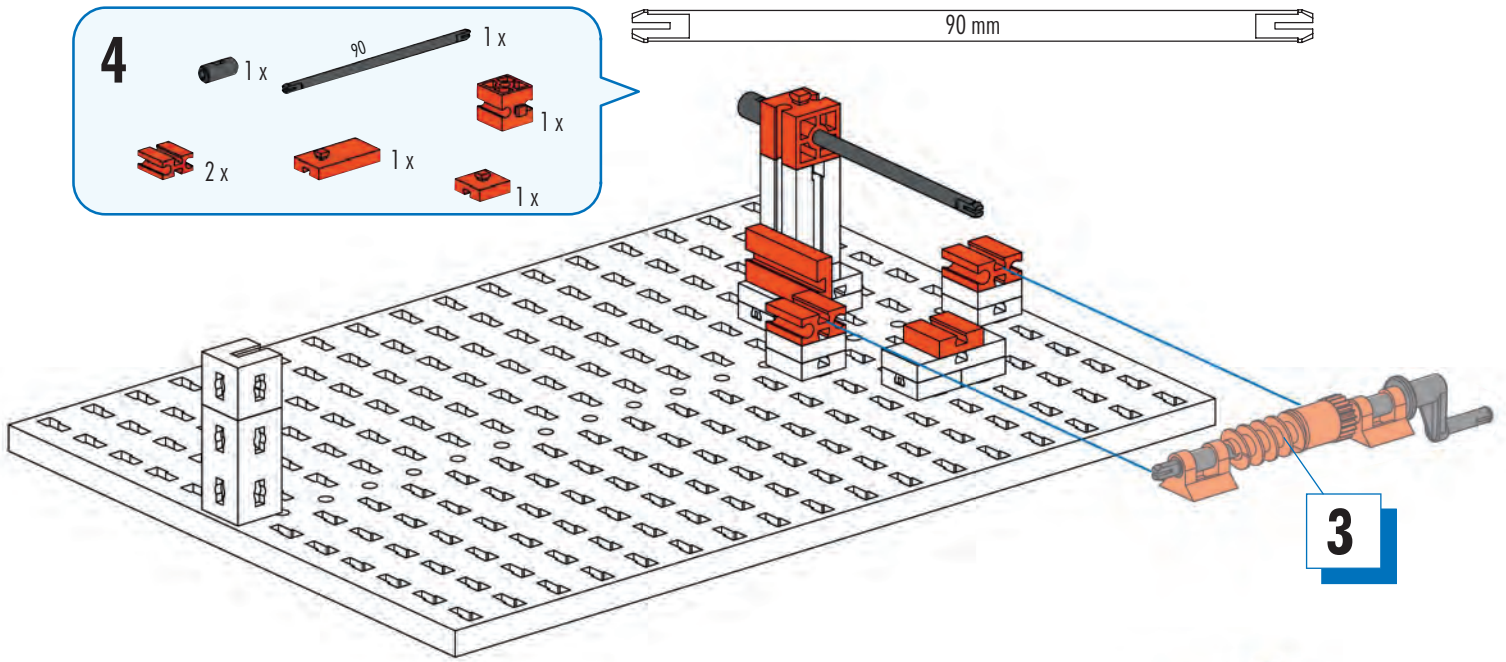
1 x





- 8  1x  1x  1x  1x

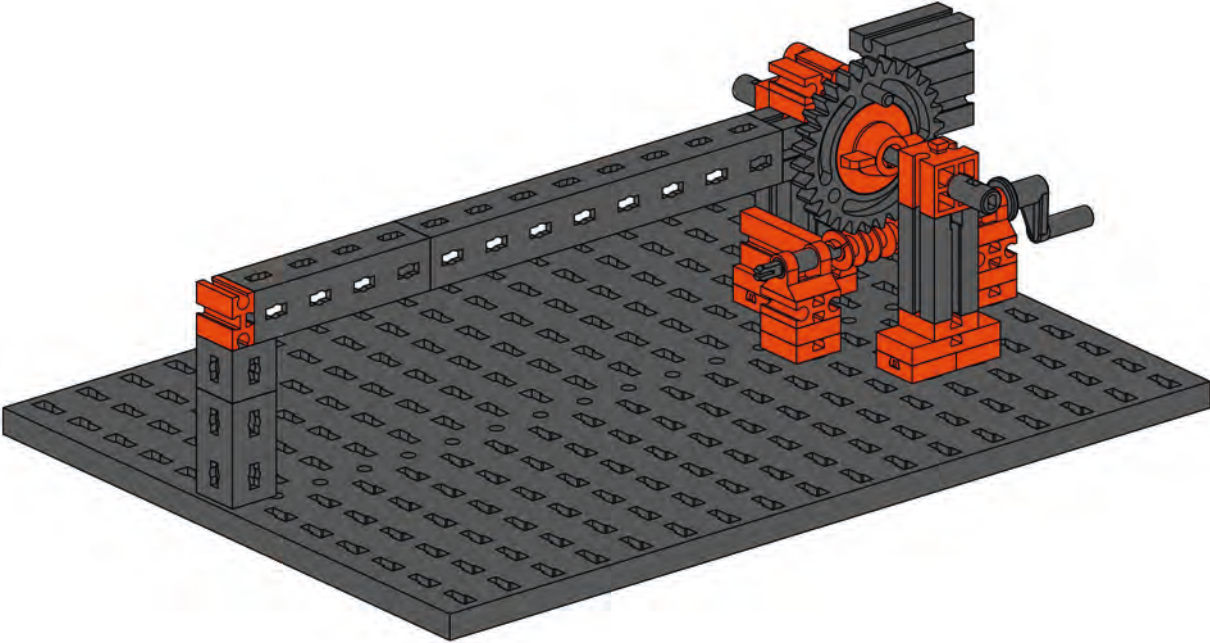
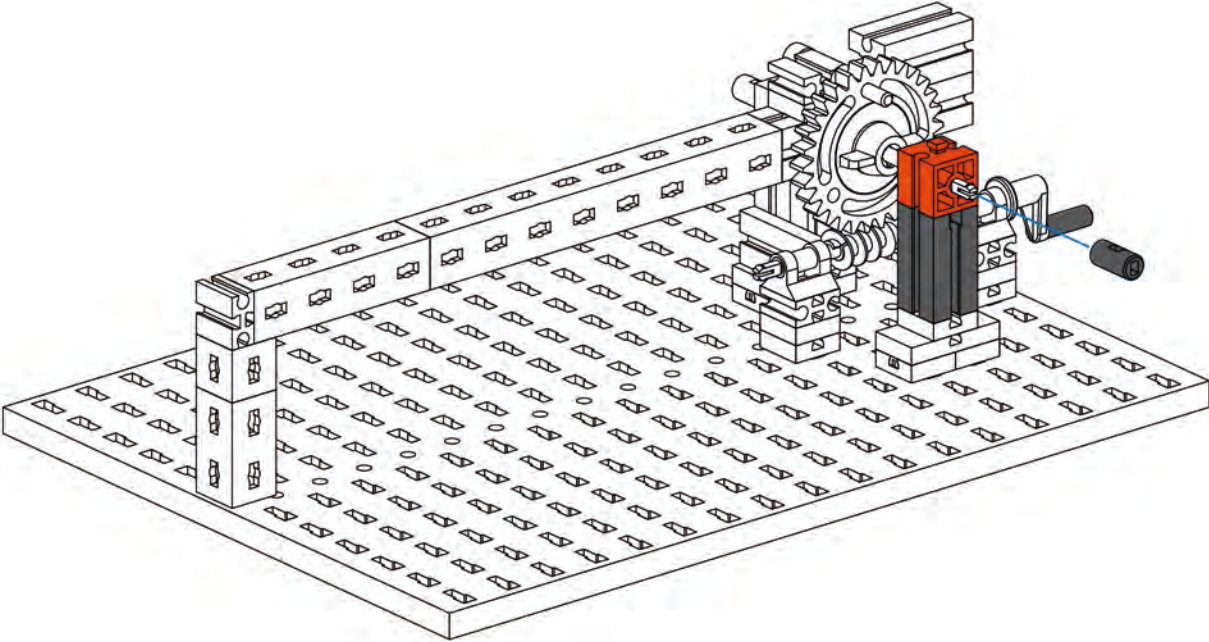

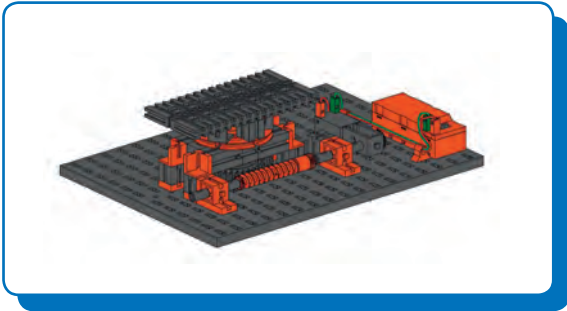

Drehtisch
Turntable
Plateau rotatif

Draaitafel
Mesa giratoria
Tavola rotante

Mesa rotatória
Поворотный стол
转台

1

1x
 5x
 1x
 2x

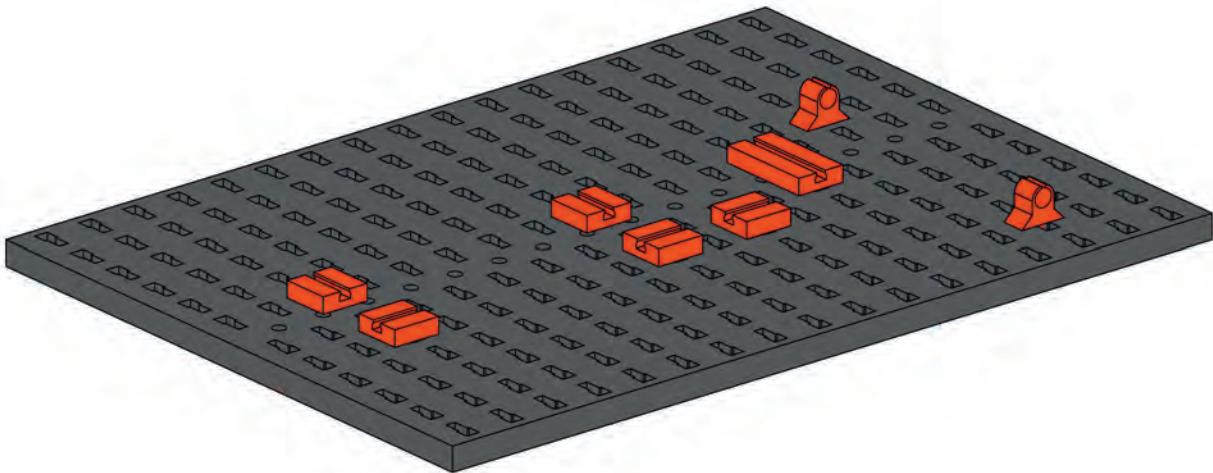

2

1x
 1x

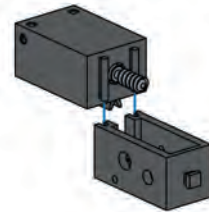

3

4x
 1x
 2x
 1x
 1x

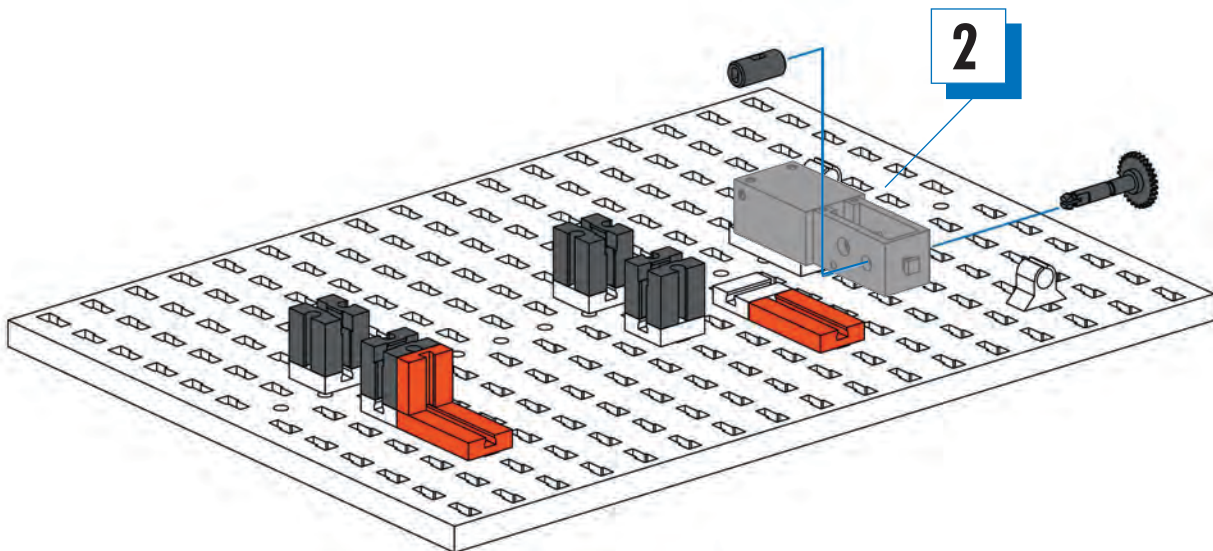

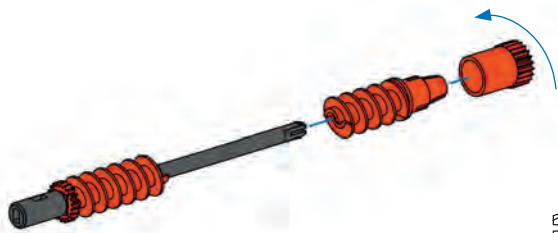

- 4**
- 90 1x
 - 1x
 - 1x
 - 1x
 - 1x
 - 1x
 - 1x

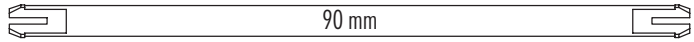

- 5**
- 1x
 - 1x
 - 1x
 - 4x
 - 30 1x
 - 1x

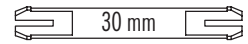

4

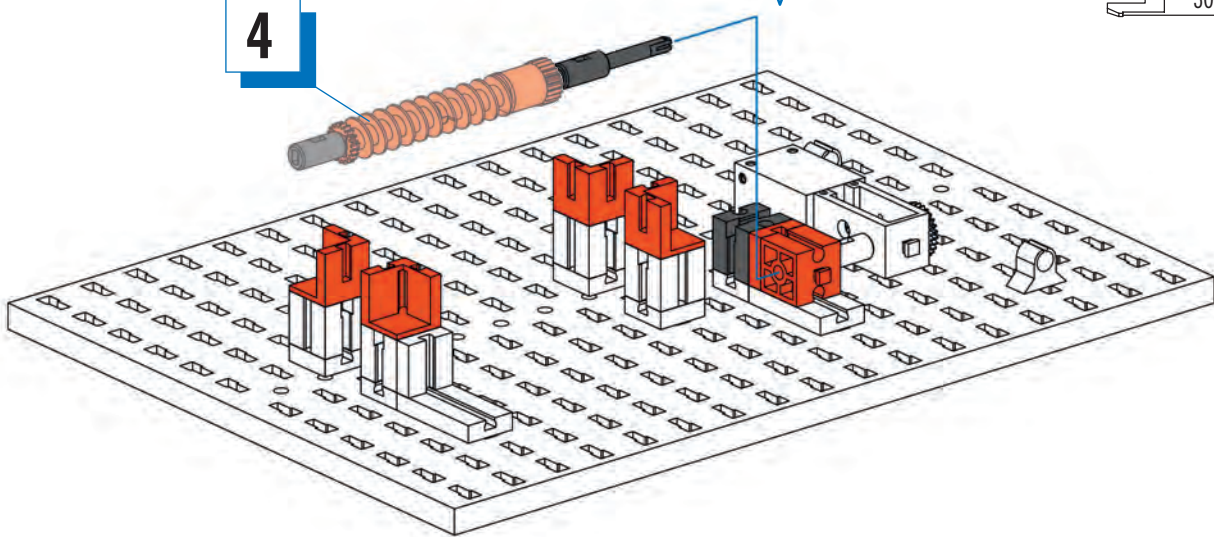

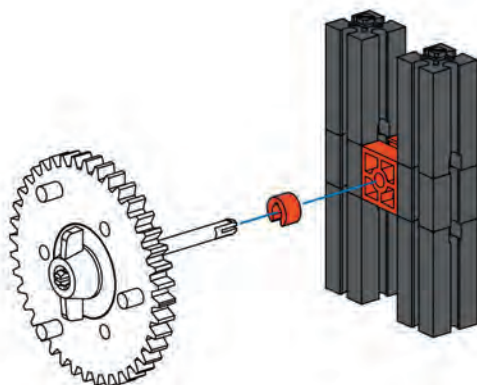
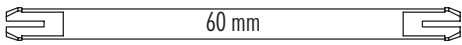
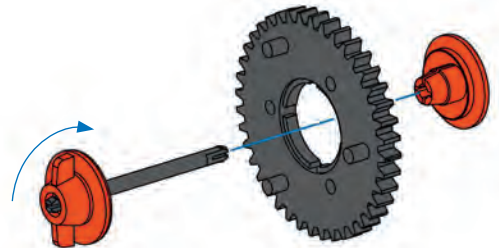

- 6**
- 60 1x
 - 1x
 - 1x
 - 1x



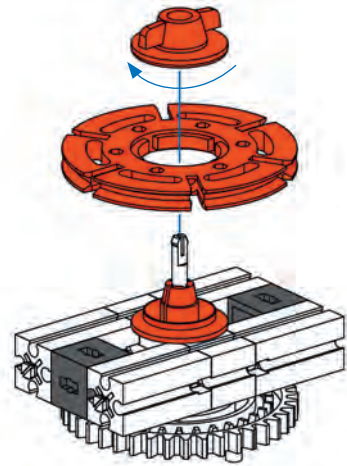

- 7**
- 4x
 - 2x
 - 1x
 - 1x

8  2x  1x  1x  1x

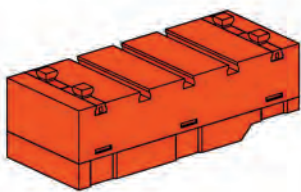
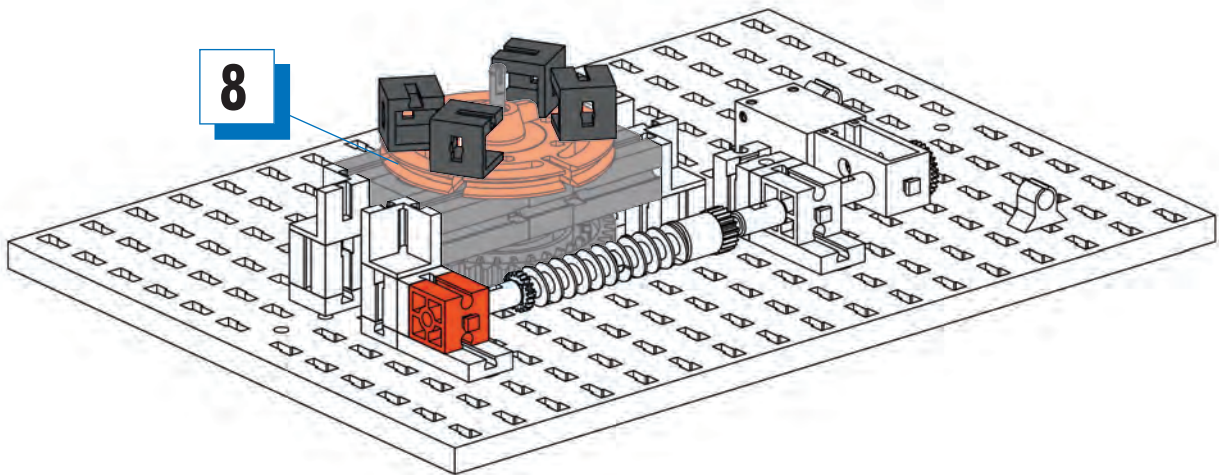

9  4x  1x

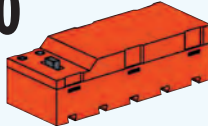

10  1x  4x

11

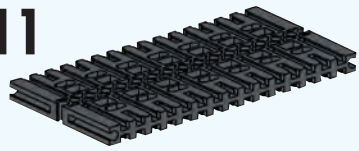

1 x



2 x

15



2 x



1 x



1 x



30 mm

10

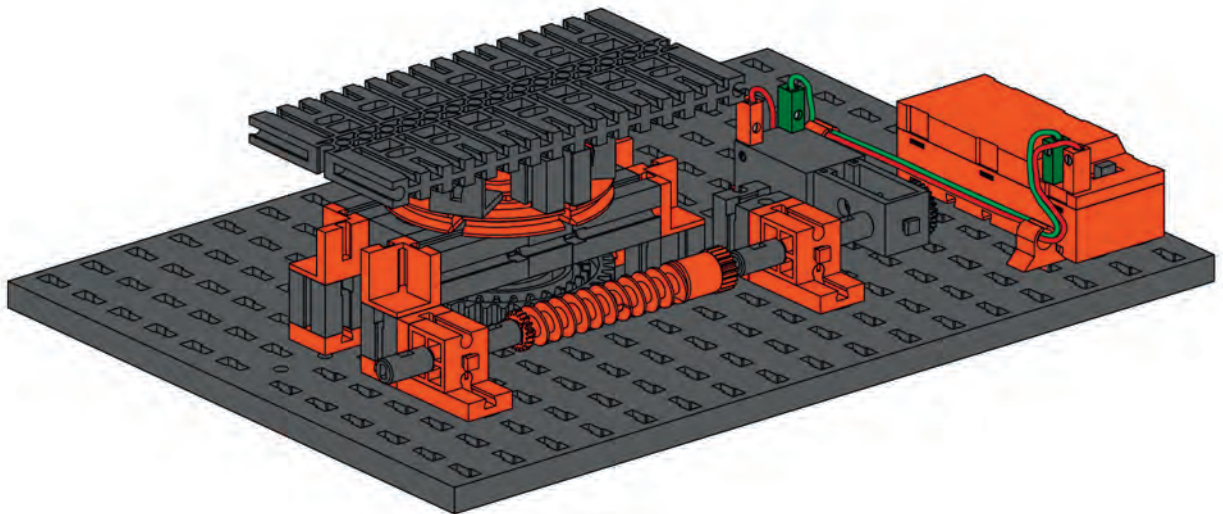
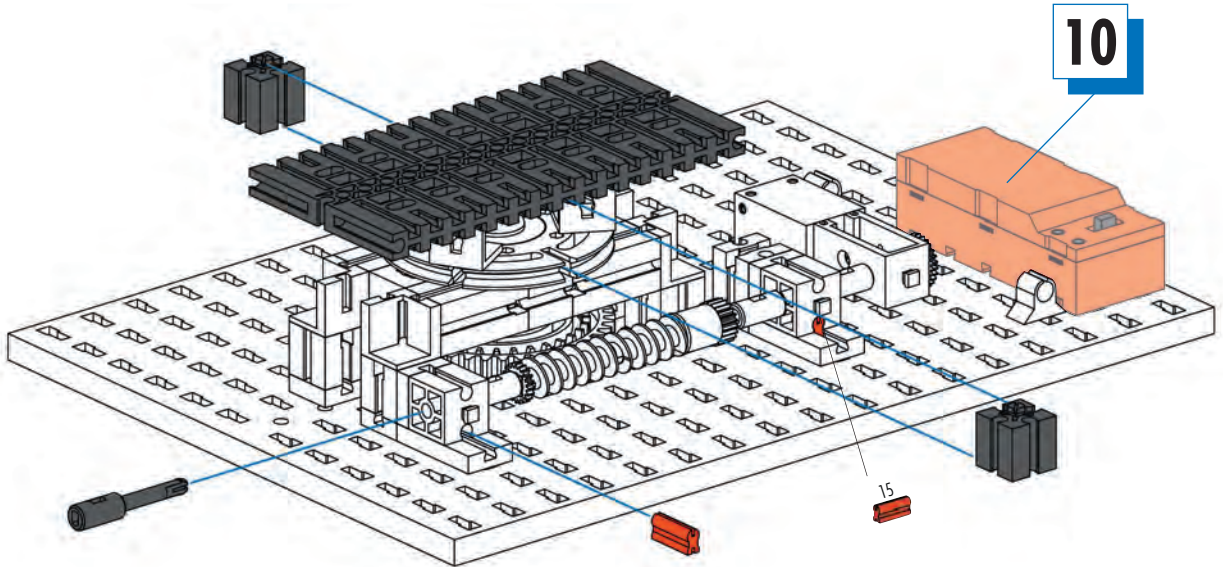

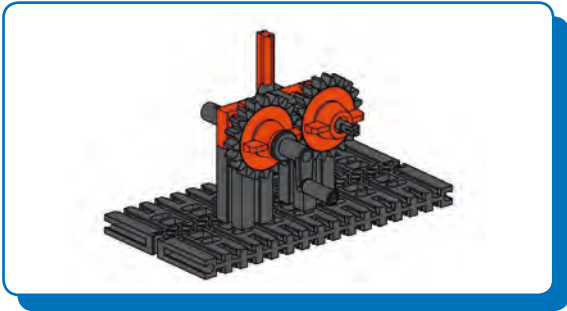

Kurbelgetriebe 1
Crank gear 1
Mécanisme à manivelle 1

Krukasoverbrenging 1
Mecanismo de manivela 1
Engrenagem de manivela 1

Ingranaggio a manovella 1
Кривошипный механизм 1
曲柄传动机构 1

1

30 1x 2x 1x 1x 45 2x 1x 1x

45 mm

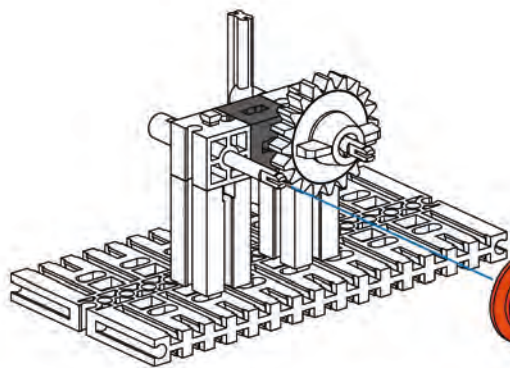
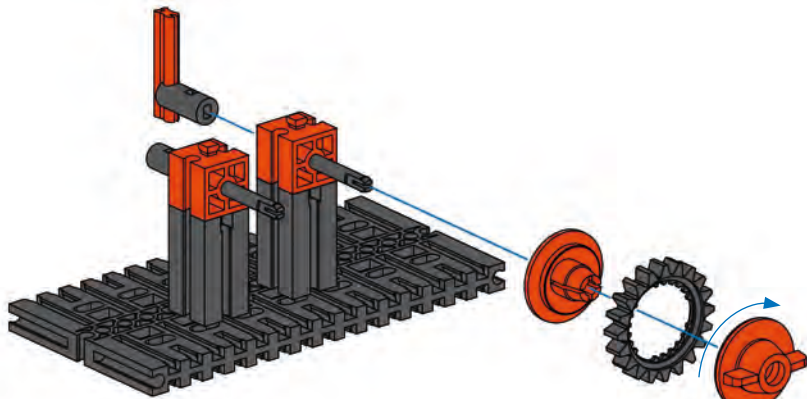

2

1x 1x 1x 1x 1x

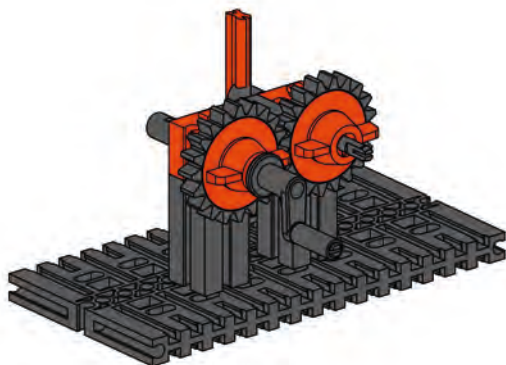
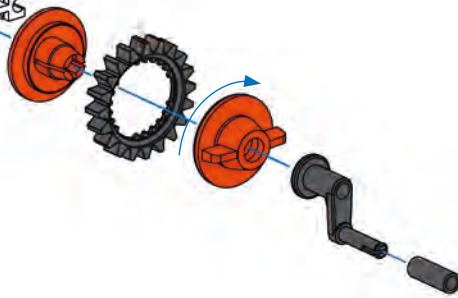

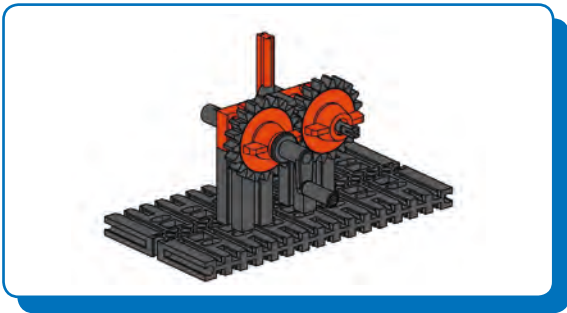

Kurbelgetriebe 2
Crank gear 2
Mécanisme à manivelle 2

Krukasoverbrenging 2
Mecanismo de manivela 2
Engrenagem de manivela 2

Ingranaggio a manovella 2
Кривошипный механизм 2
曲柄传动机构 2

1

30 1x
 2x 1x
 1x
 1x
 45 2x
 2x
 1x

45 mm

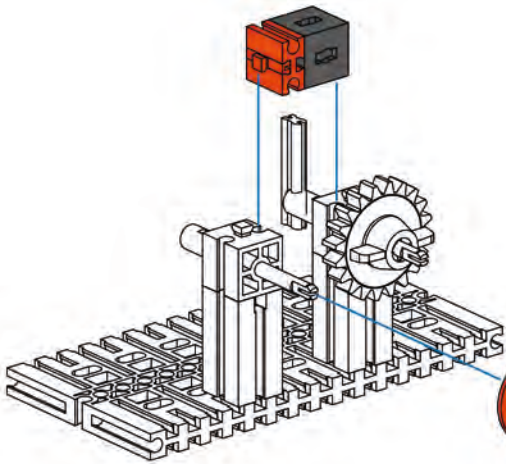
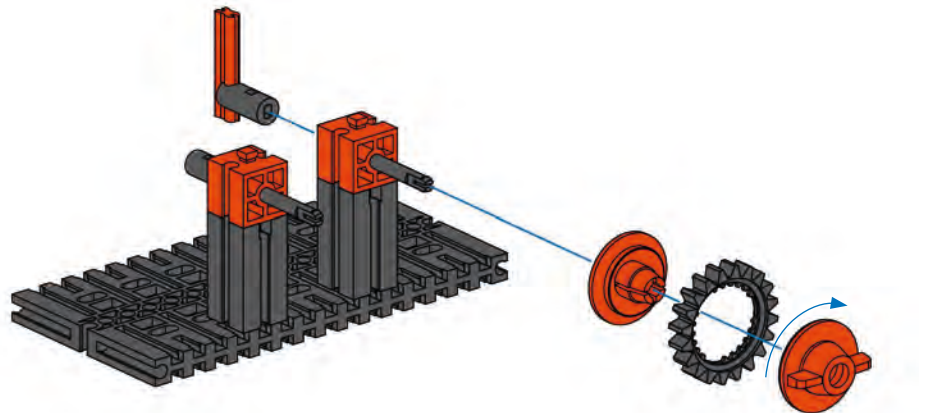

2

1x
 1x
 1x
 1x
 1x
 1x
 1x

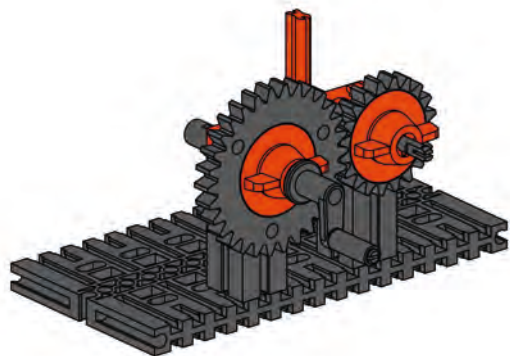
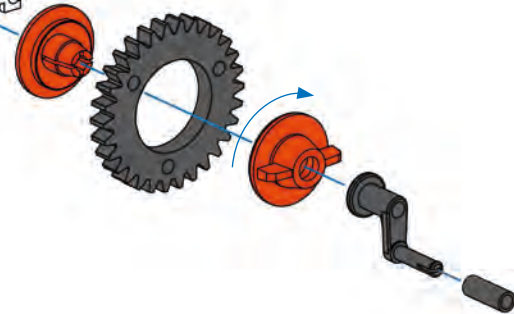

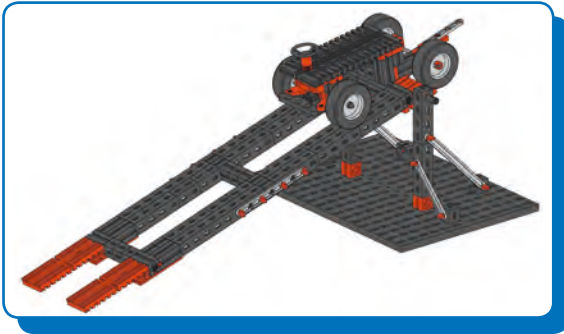

Schiefe Ebene mit Fahrzeug
Inclined plane with vehicle
Plan incliné avec véhicule

Helling met voertuig
Plano inclinado con vehículo
Rampa com veículo

Piano inclinato con veicolo
Наклонный пандус с автомобилем
配备车辆的斜面

1

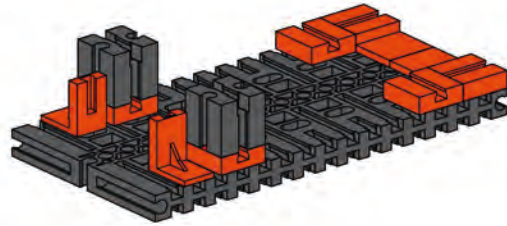
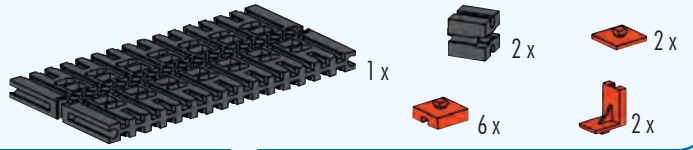

2

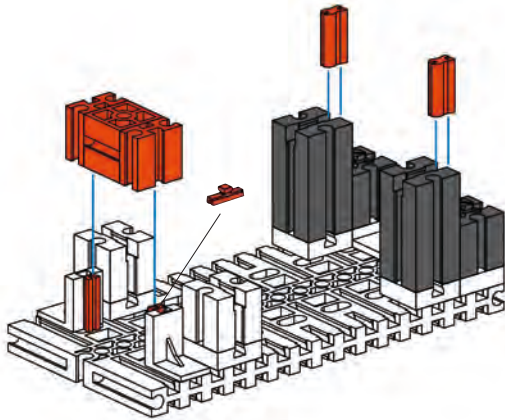
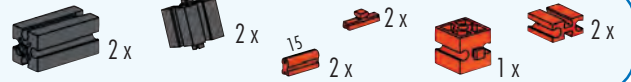

3

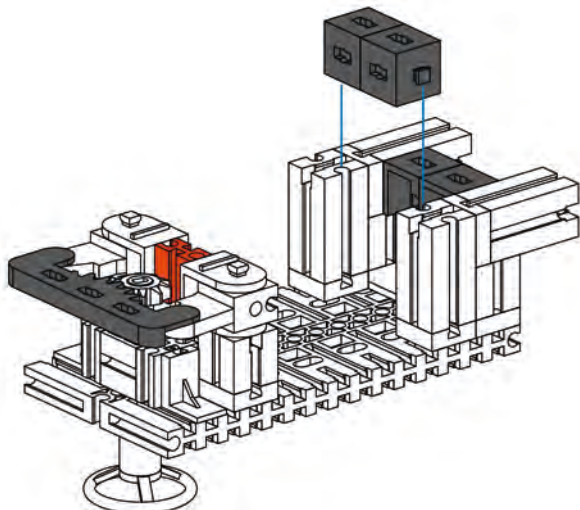
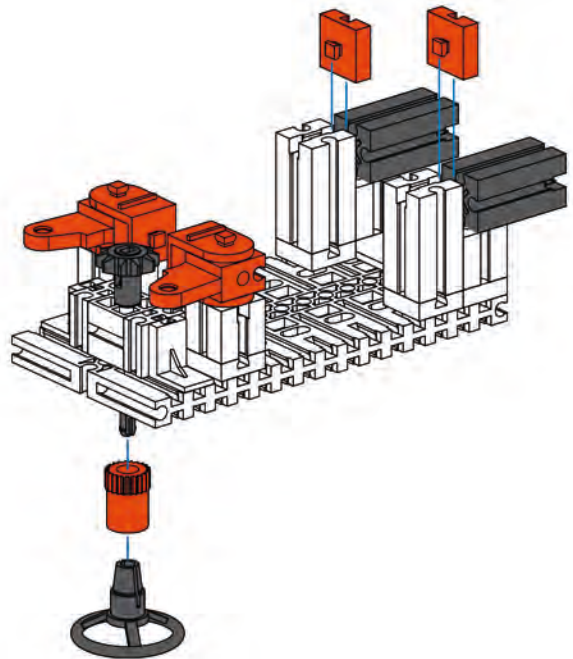
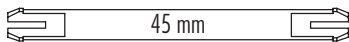
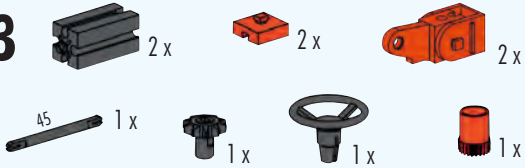

4



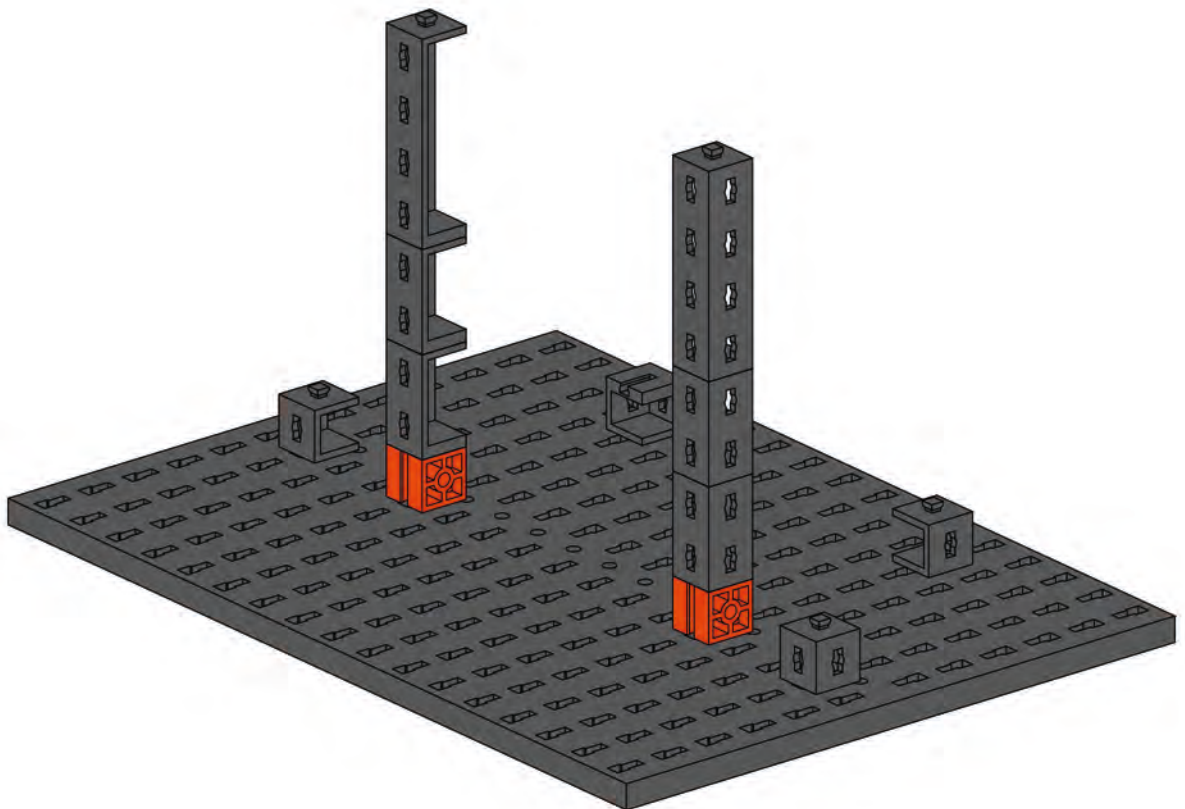
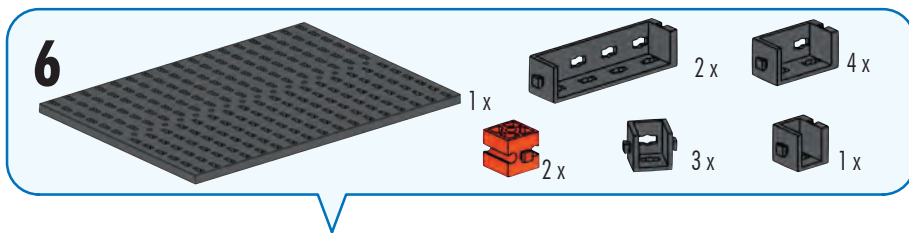
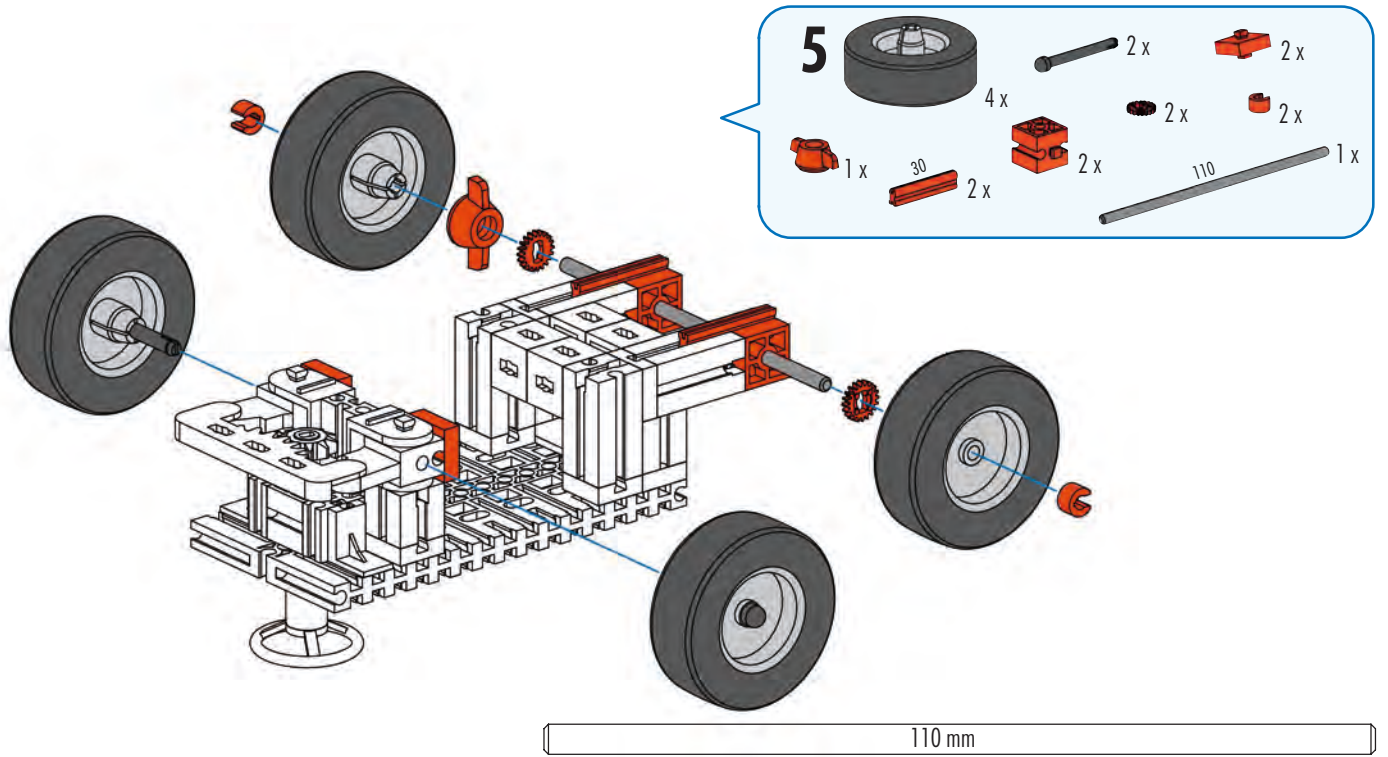

7

- 63,6 2x
- 106 2x
- 8x

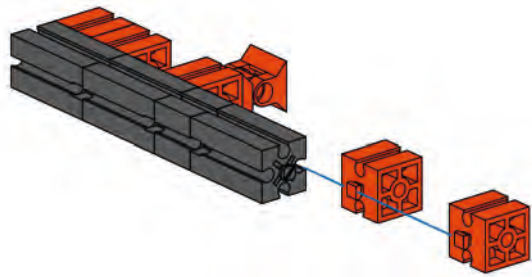
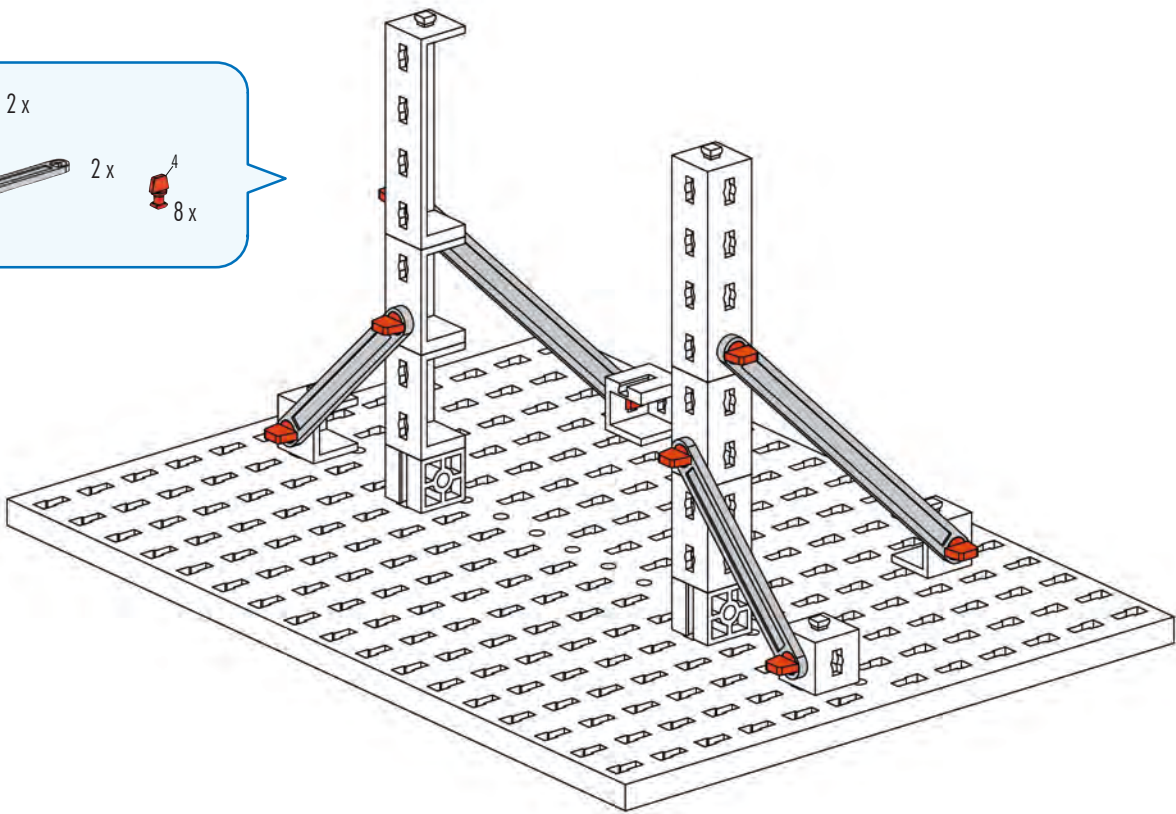

8

- 3x
- 1x
- 5x
- 1x

9

- 2x
- 8x
- 4x
- 5x
- 1x

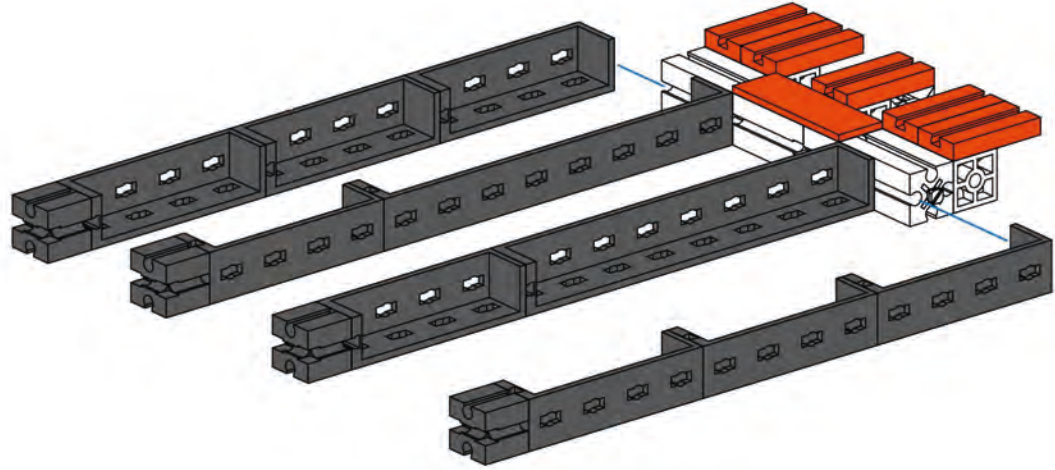

10

- 2x [Black 2-hole Technic Pin]
- 1x [Black 1-hole Technic Pin]
- 4x [Red 1-hole Technic Pin]
- 15 [Red 1-hole Technic Pin]
- 2x [Red 1-hole Technic Pin]

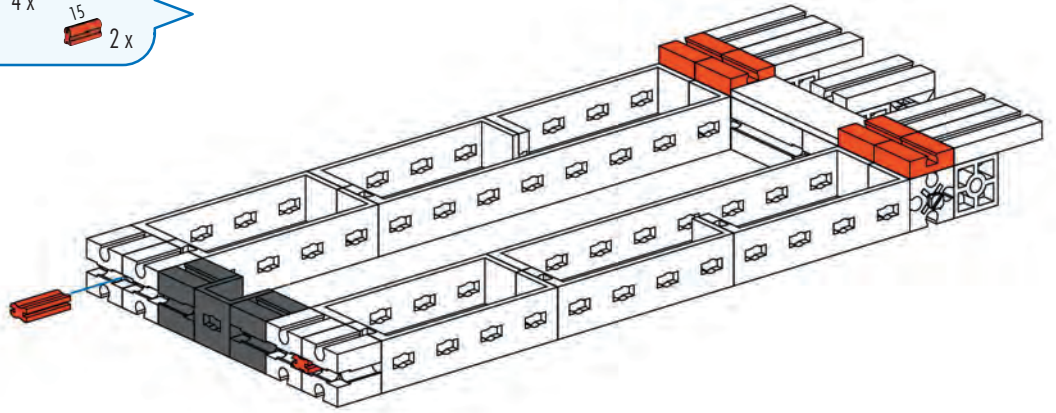

11

- 2x [Black 1-hole Technic Pin]
- 4x [Black 1-hole Technic Pin]
- 2x [Black 2-hole Technic Pin]
- 2x [Black 2-hole Technic Pin]
- 1x [Red 1-hole Technic Pin]
- 1x [Red 1-hole Technic Pin]

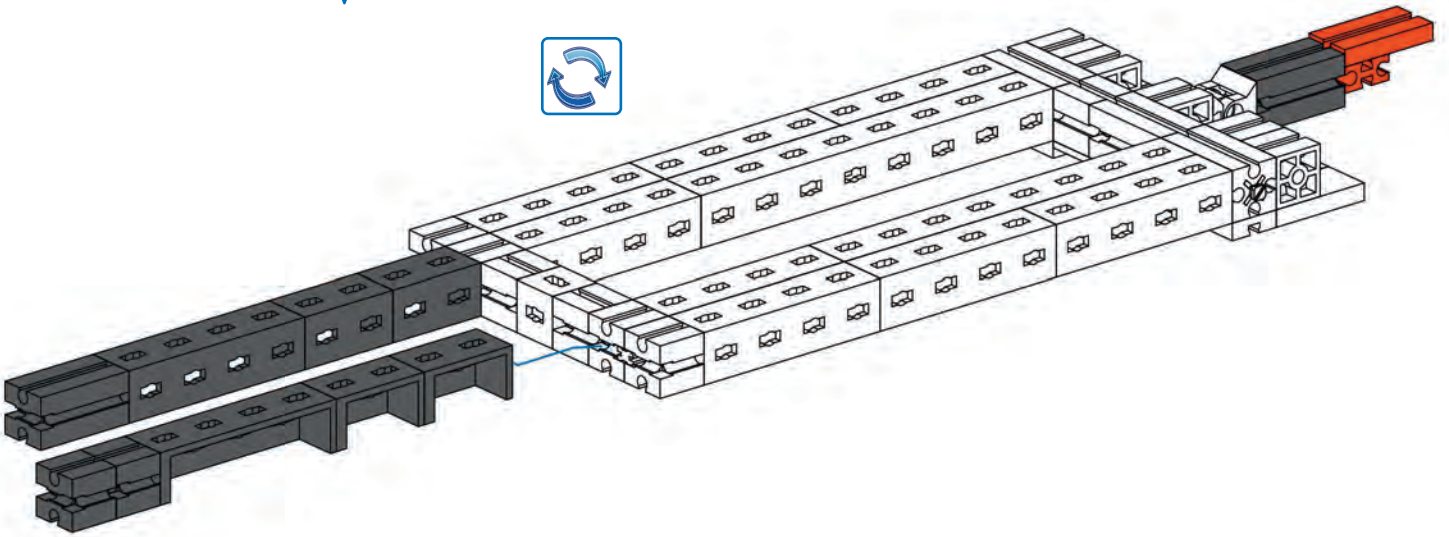

12

- 2x [Black 1-hole Technic Pin]
- 2x [Black 2-hole Technic Pin]
- 15 [Red 1-hole Technic Pin]
- 2x [Red 1-hole Technic Pin]
- 2x [Red 1-hole Technic Pin]

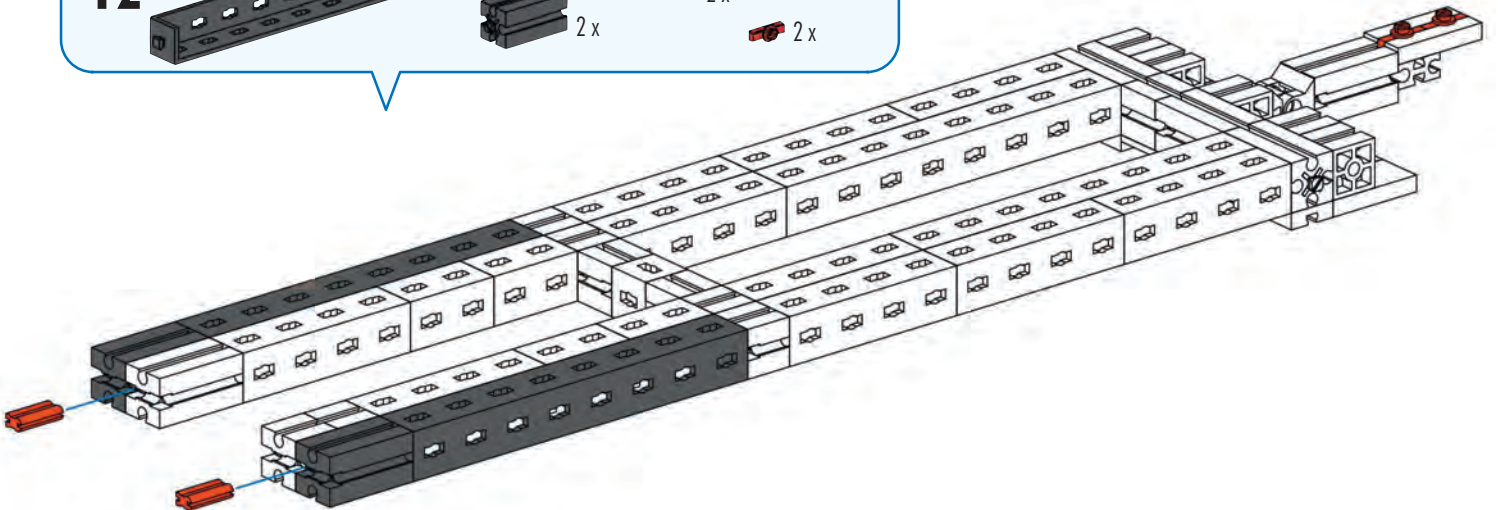

13

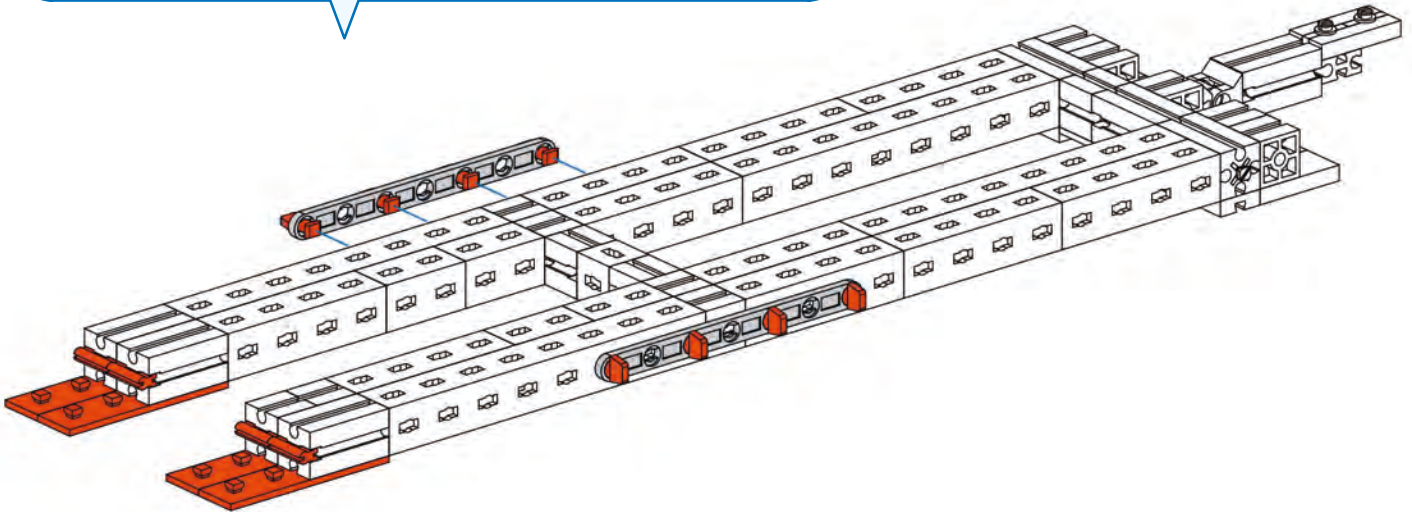

14

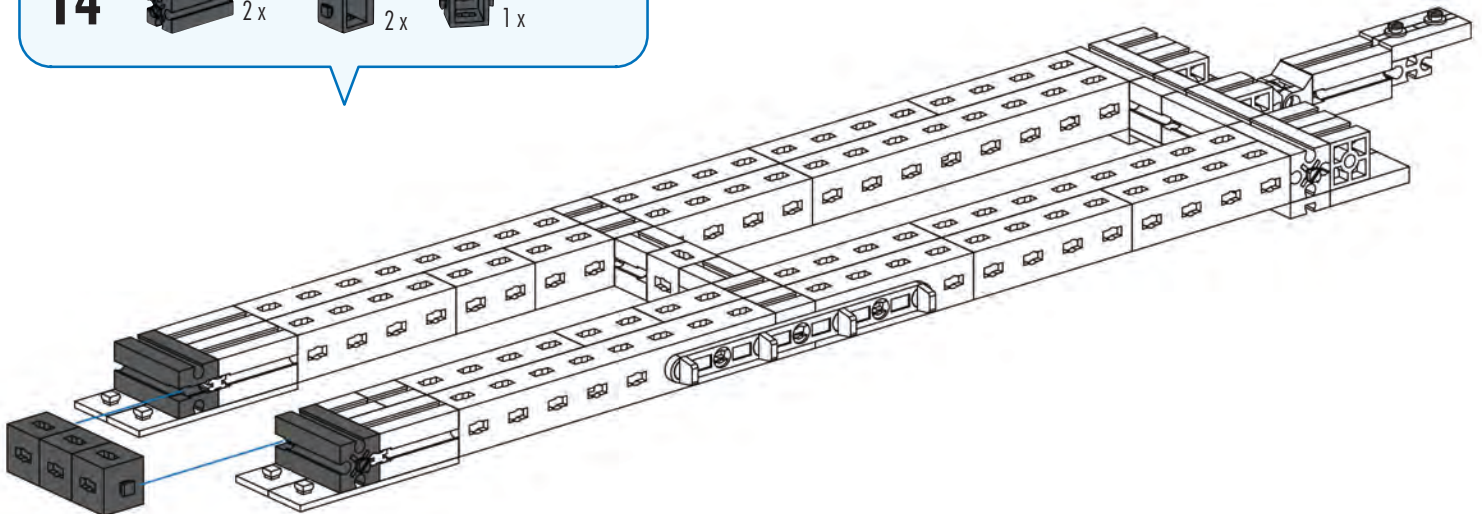

15

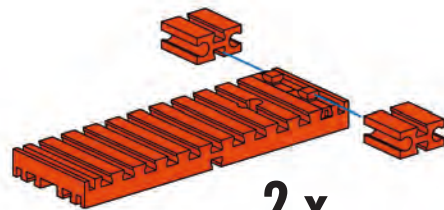
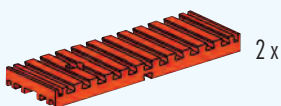

16

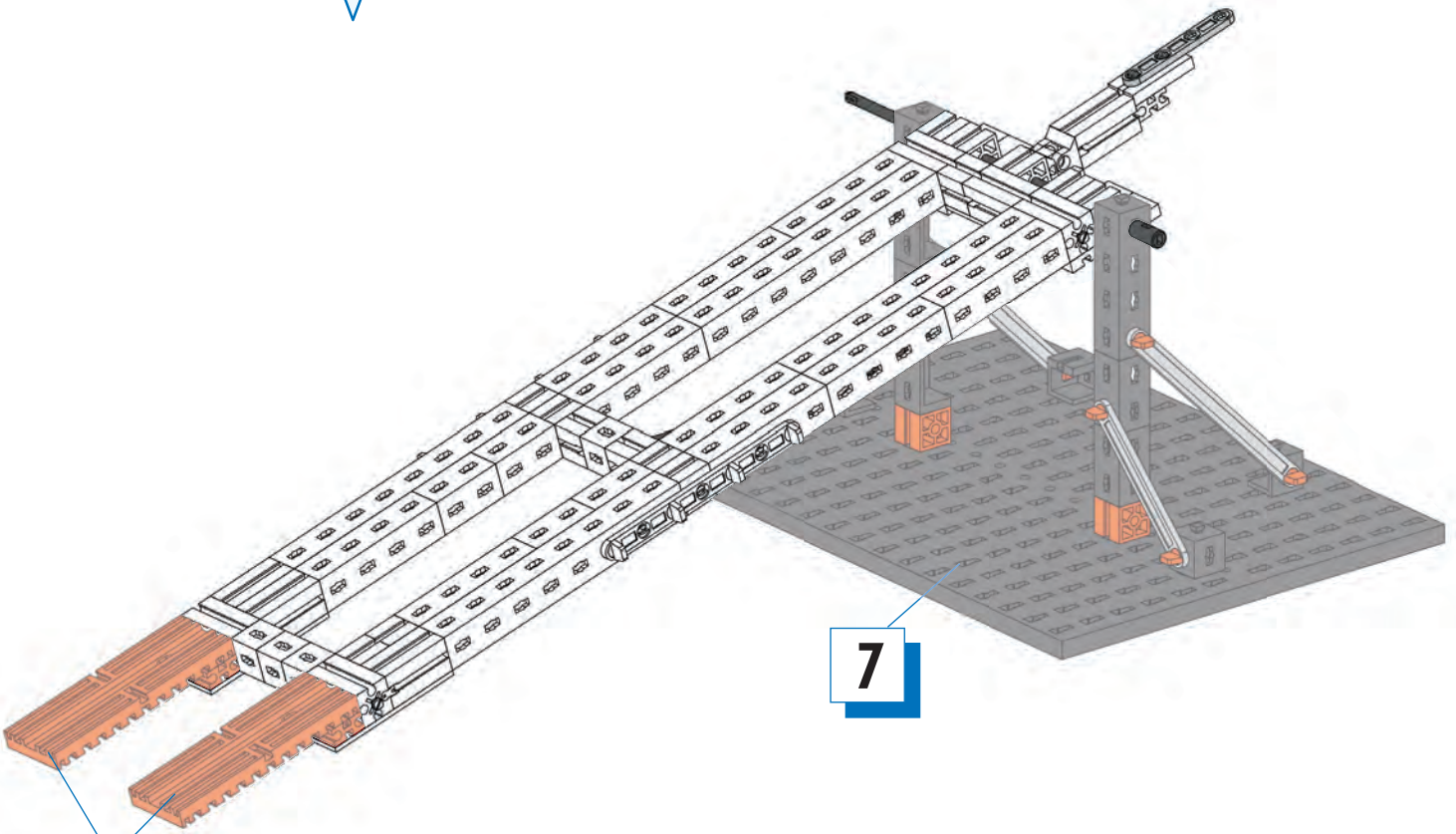

15

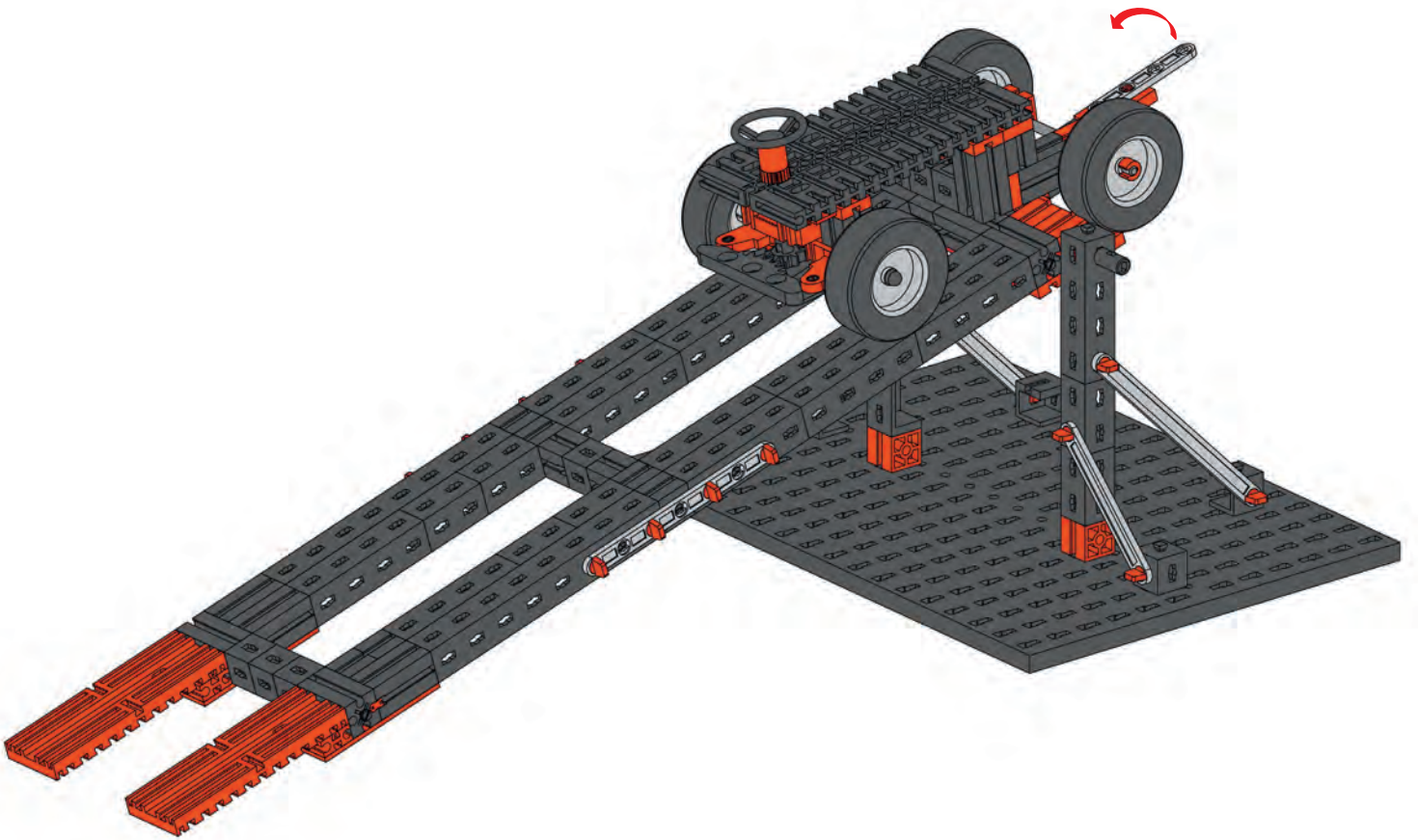

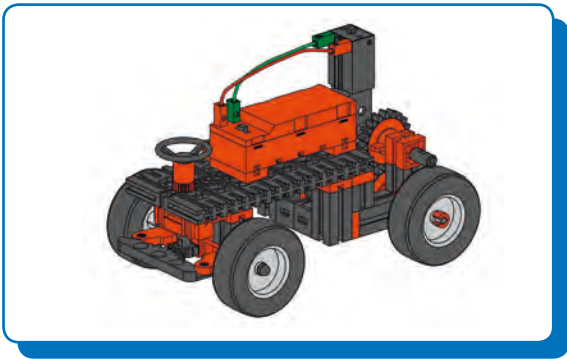

Fahrzeug 1
Vehicle 1
Véhicule 1

Voertuig 1
Vehículo 1
Veículo 1

Veicolo 1
Автомобиль 1
1号汽车

5

- 2 x 2x orange Technic brick
- 2 x 30 orange Technic axle
- 1 x 110 grey Technic axle
- 1 x red Technic bush
- 1 x red Technic bush
- 1 x black Technic gear
- 2 x black Technic axle pin

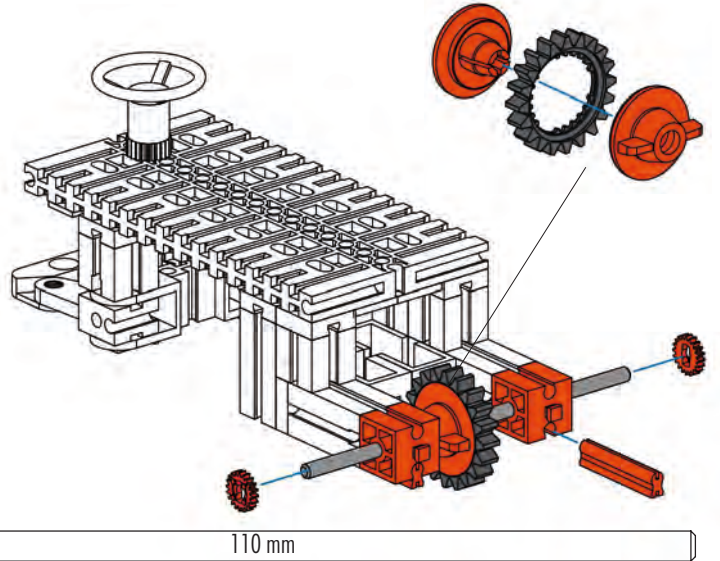

1-4

Seite 17
Page 17
Page 17
Bladzijde 17
Página 17
Pagina 17
Página 17
Страница 17
页次 17

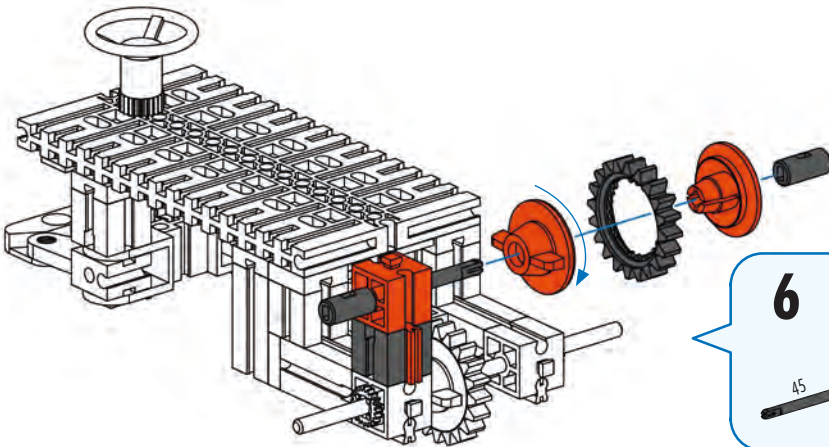

6

- 1 x black Technic bush
- 1 x 2x orange Technic brick
- 1 x red Technic bush
- 1 x black Technic gear
- 1 x 45 grey Technic axle
- 2 x black Technic axle pin
- 1 x 15 orange Technic axle
- 1 x red Technic bush

7

- 1 x black Technic bush
- 1 x 15 orange Technic axle
- 2 x red Technic bush
- 4 x orange Technic brick

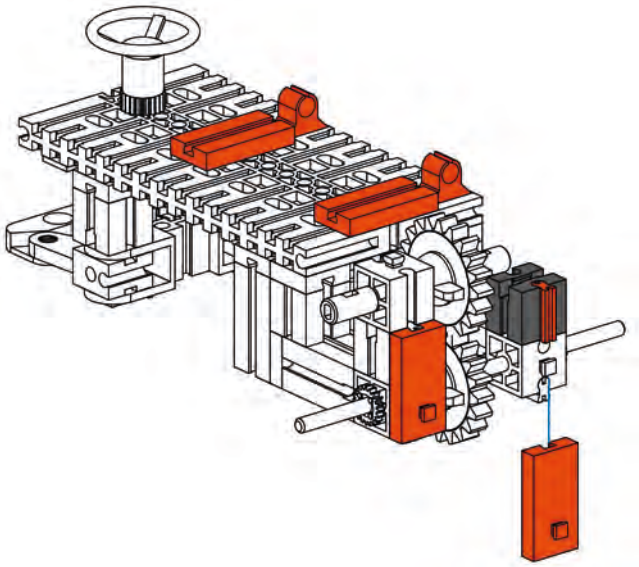

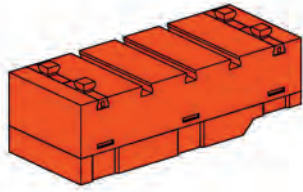

8

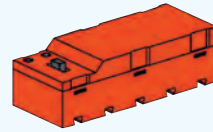

1 x

4 x

9



1 x



1 x



1 x

8

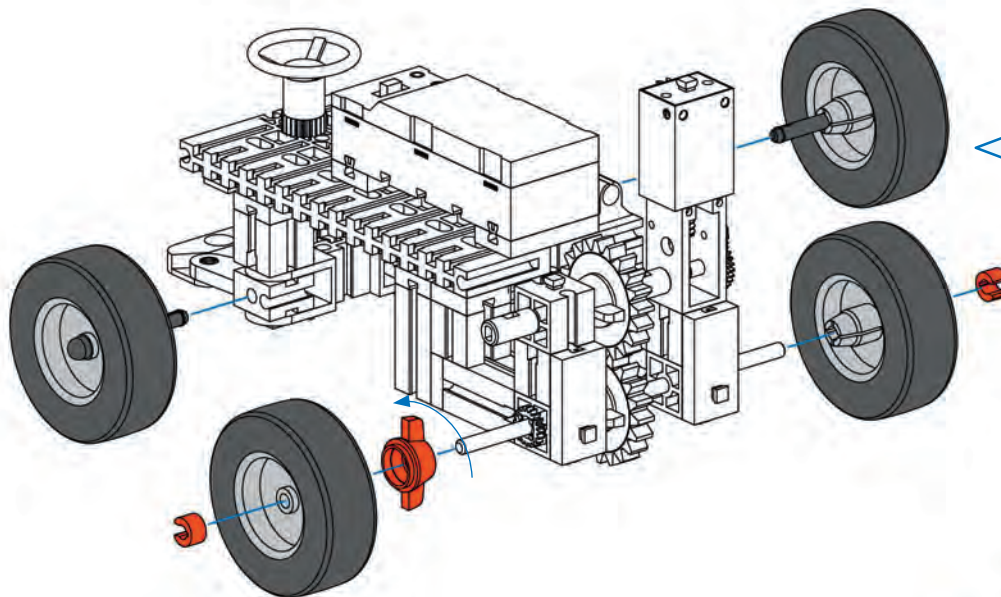
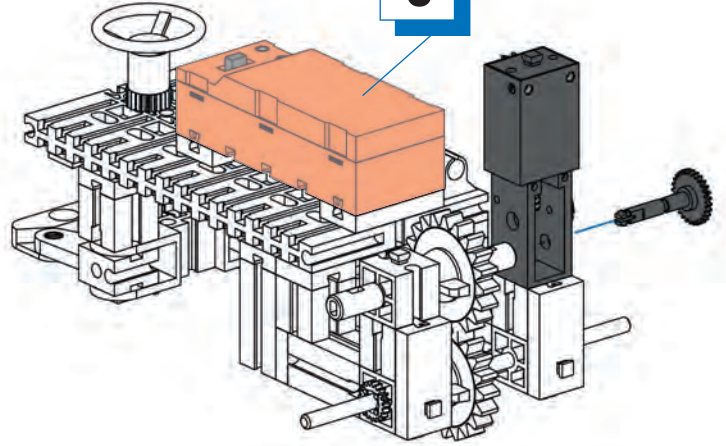

10

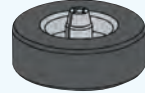

4 x

2 x



1 x



2 x

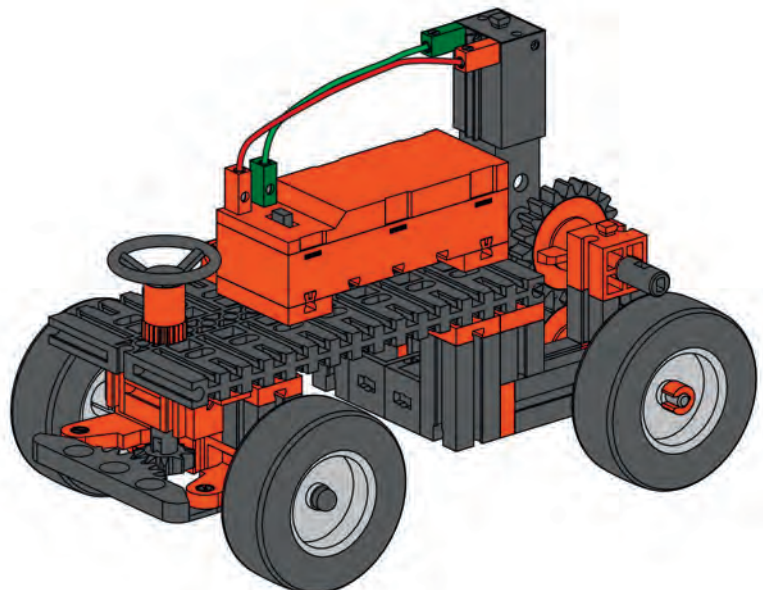



Fahrzeug 2
Vehicle 2
Véhicule 2

Voertuig 2
Vehículo 2
Veículo 2

Veicolo 2
Автомобиль 2
2号汽车

5

- 2 x 2x
- 30 2x
- 110 1x
- 1x
- 1x
- 1x
- 1x
- 2x

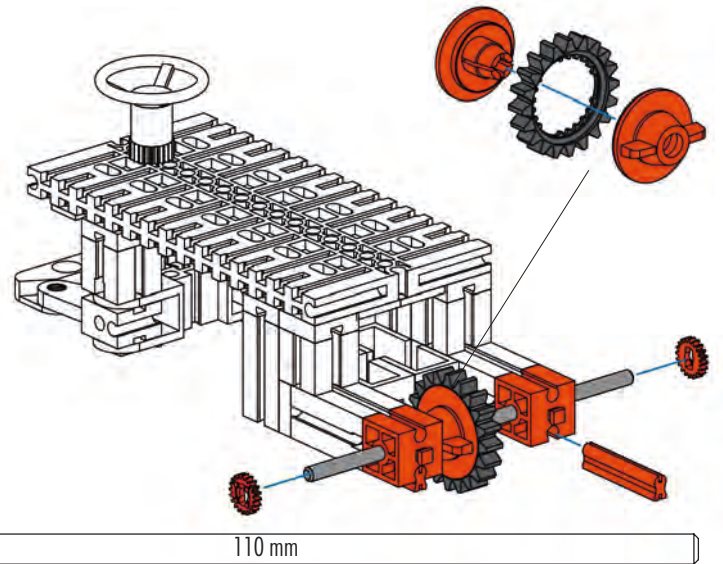

1-4

Seite 17
Page 17
Page 17
Bladzijde 17
Página 17
Página 17
Página 17
Страница 17
页次 17

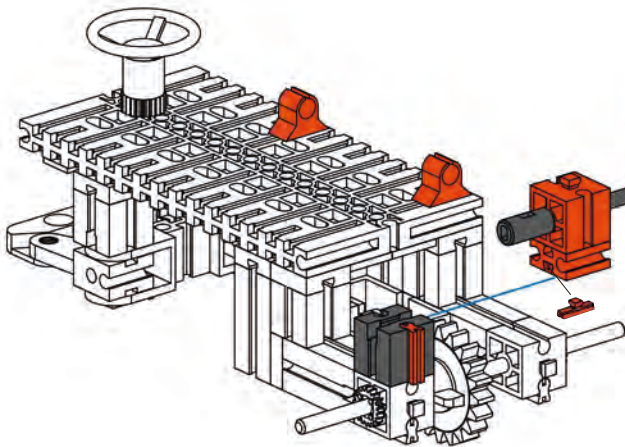

6

- 1x
- 1x
- 1x
- 1x
- 1x
- 2x
- 15 1x
- 2x
- 1x
- 1x
- 1x

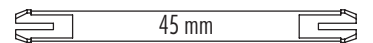

7

- 1x
- 15 1x
- 4x
- 1x
- 1x

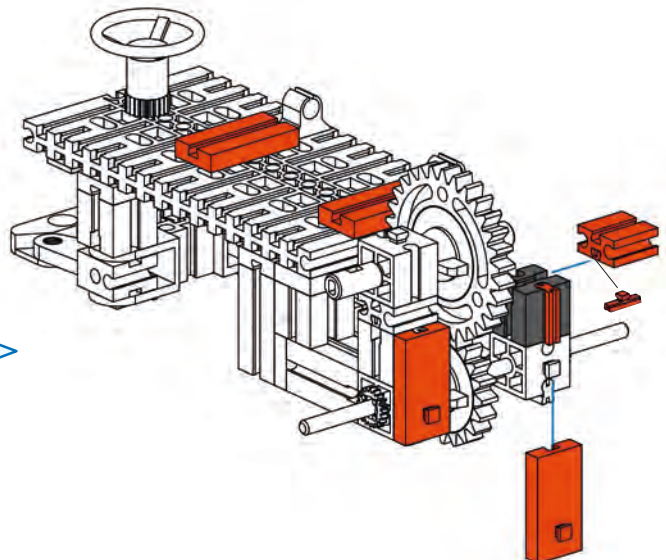

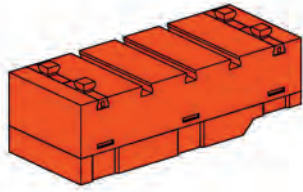

8

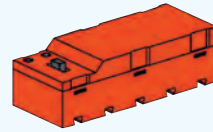

1 x

4 x

9



1 x



1 x



1 x

8

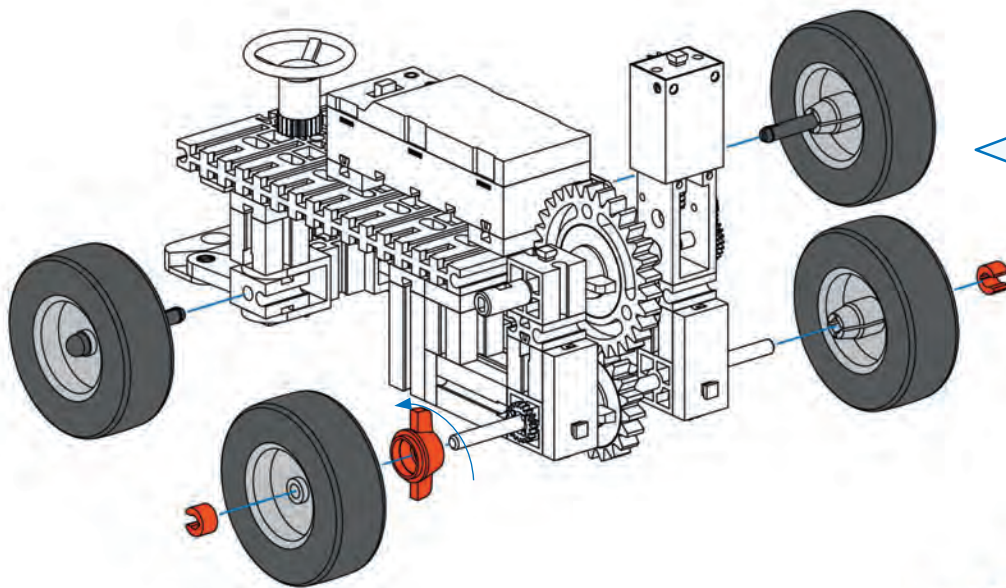
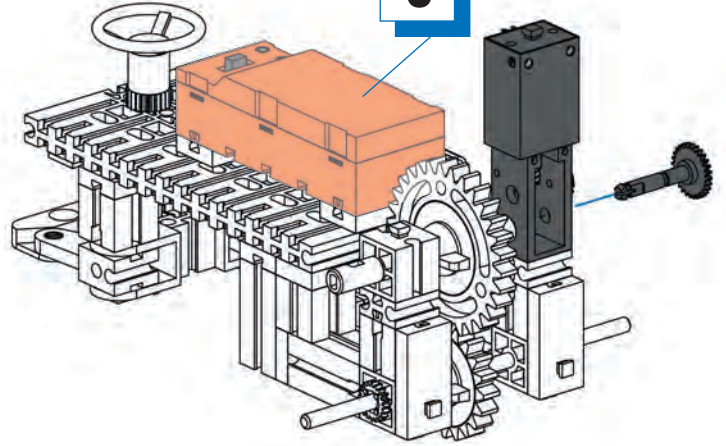

10

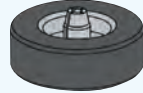

4 x

2 x



1 x



2 x

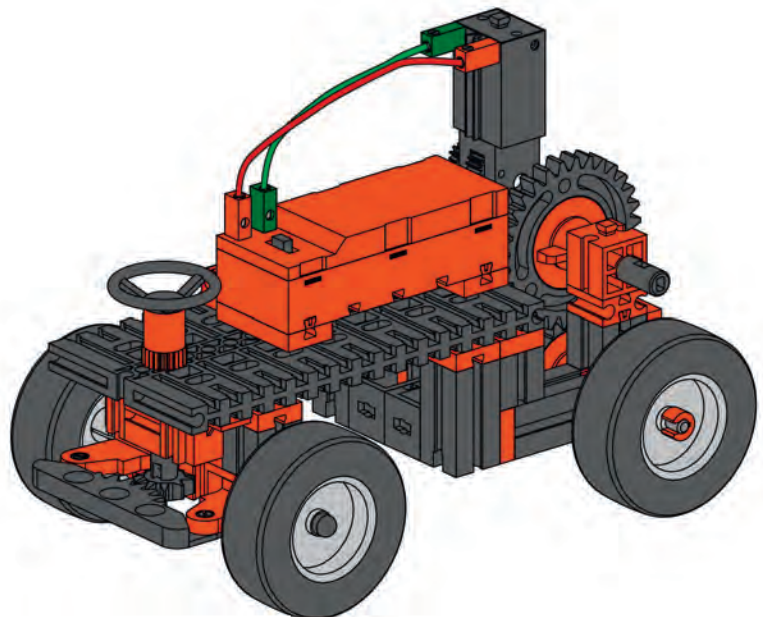



Fahrzeug 3
Vehicle 3
Véhicule 3

Voertuig 3
Vehículo 3
Veículo 3

Veicolo 3
Автомобиль 3
3号汽车

5

- 2 x
- 2 x
- 1 x
- 1 x
- 1 x
- 1 x
- 2 x

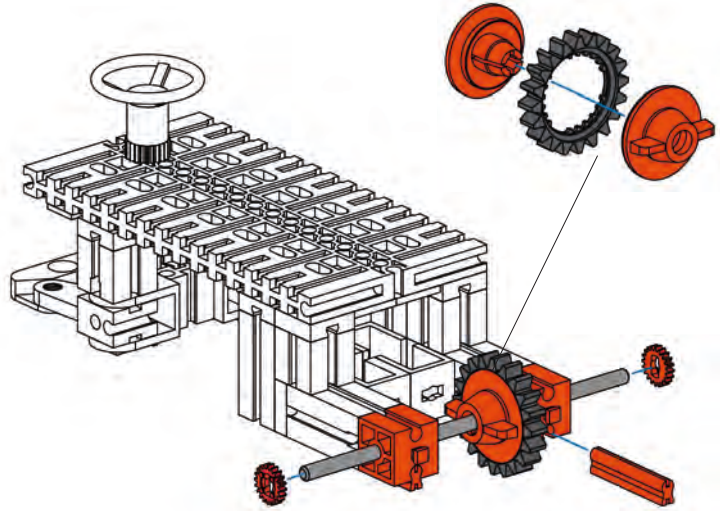

110 mm

1-4

Seite 17
Page 17
Page 17
Bladzijde 17
Página 17
Página 17
Página 17
Страница 17
页次 17

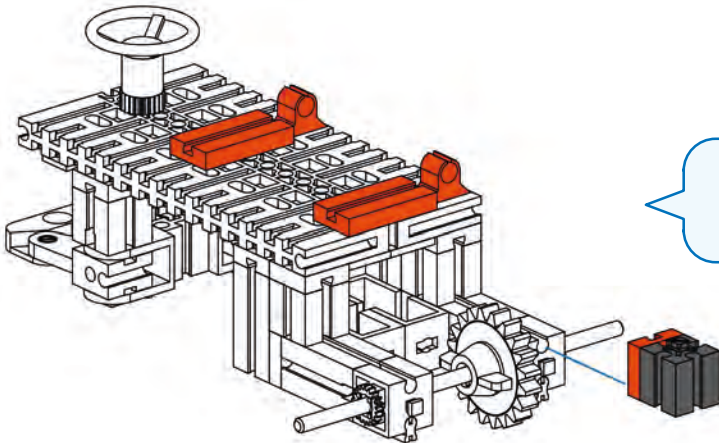

6

- 1 x
- 2 x
- 2 x
- 1 x

7

- 1 x
- 4 x

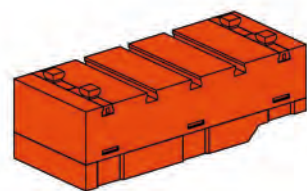

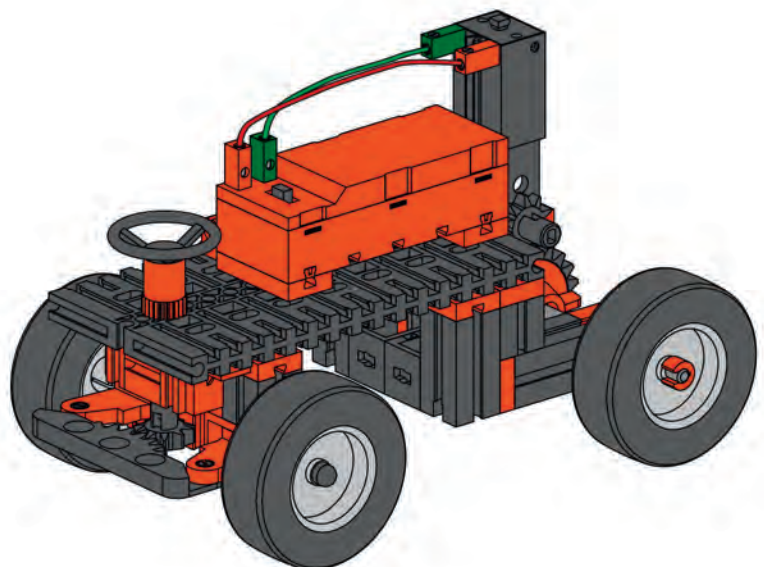
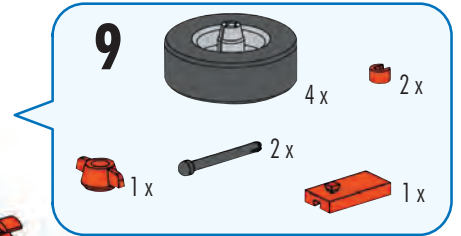
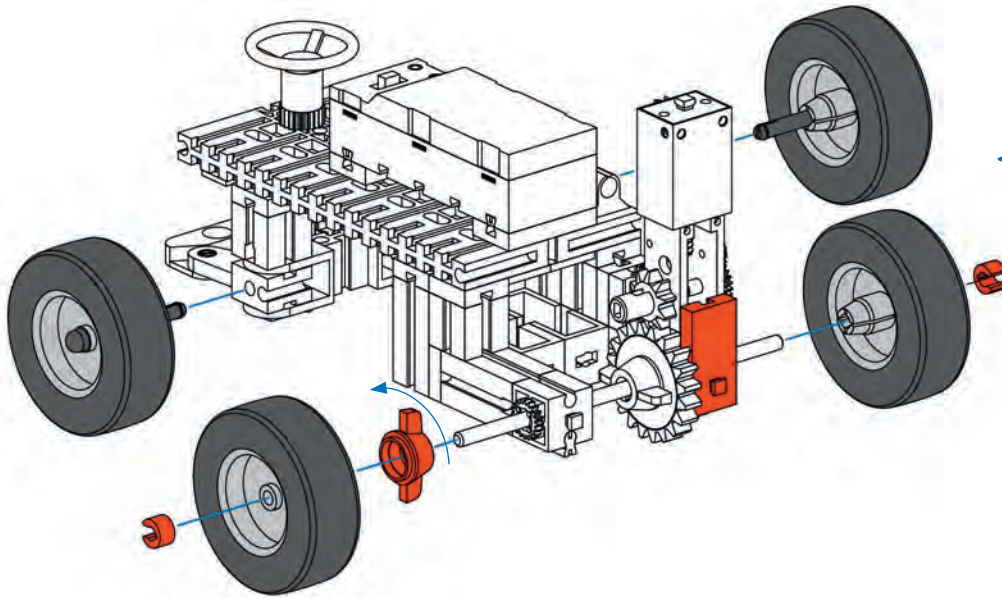
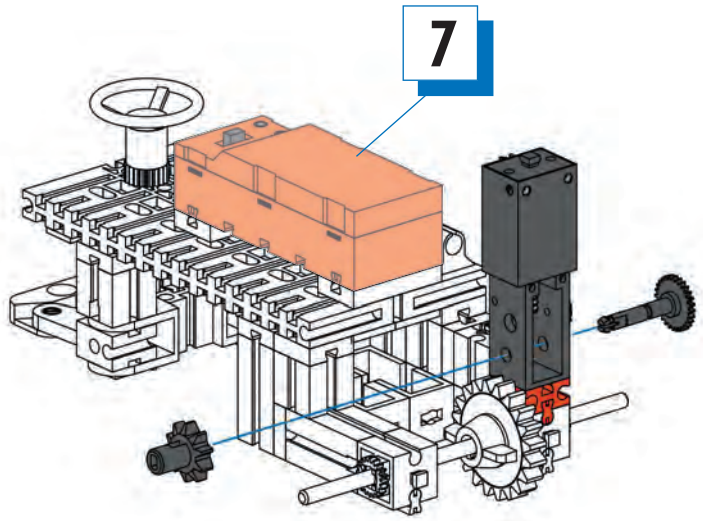
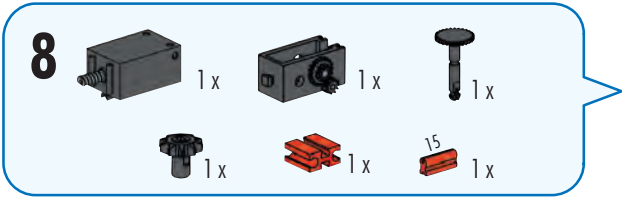

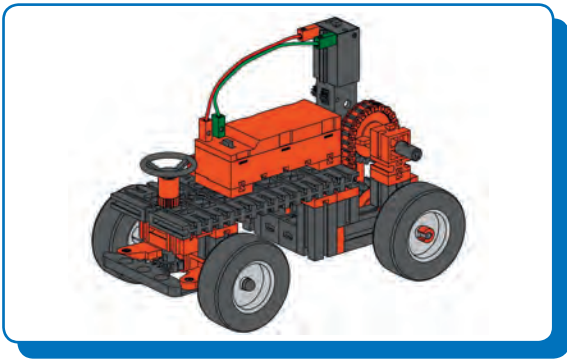

Fahrzeug 4
Vehicle 4
Véhicule 4

Voertuig 4
Vehículo 4
Veículo 4

Veicolo 4
Автомобиль 4
4号汽车

5

- 2 x 1x2x2 Technic brick
- 2 x 30 Technic axle
- 1 x 110 Technic axle
- 1 x Red axle pin
- 1 x Red axle pin
- 1 x 24 Tooth Technic gear
- 2 x Black axle bush

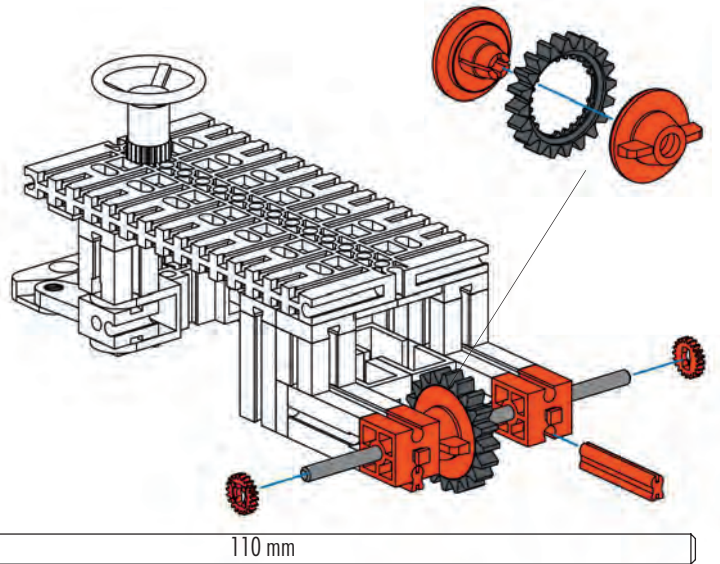

1-4

- Seite 17
- Page 17
- Page 17
- Bladzijde 17
- Página 17
- Página 17
- Página 17
- Страница 17
- 页次 17

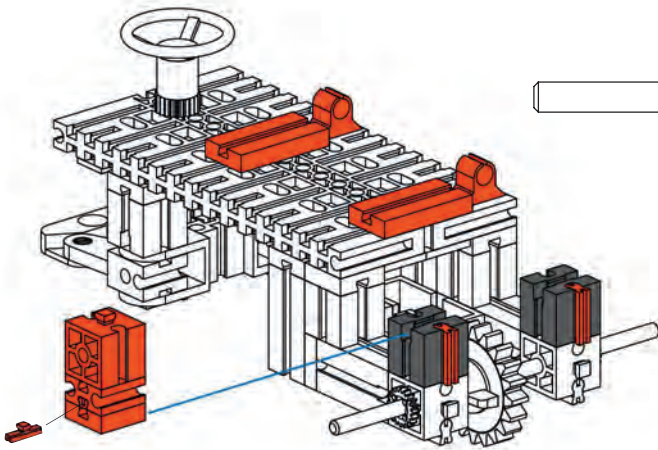

110 mm

6

- 2 x 1x2x2 Technic brick
- 1 x 1x2x2 Technic brick
- 2 x 30 Technic axle
- 2 x Red axle pin
- 1 x 1x2x2 Technic brick
- 1 x 1x2x2 Technic brick
- 1 x 1x2x2 Technic brick
- 2 x 15 Technic axle

7

- 1 x 1x4x4 Technic brick
- 4 x 1x2x2 Technic brick

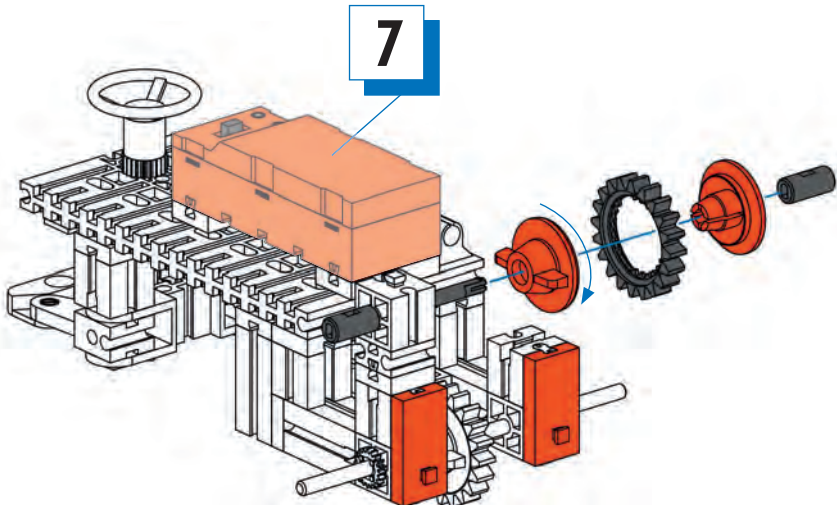
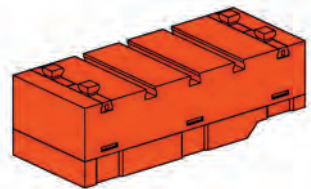

8

- 1 x Red axle pin
- 1 x 24 Tooth Technic gear
- 1 x Red axle pin
- 1 x 45 Technic axle
- 2 x Black axle bush
- 2 x 1x2x2 Technic brick

45 mm

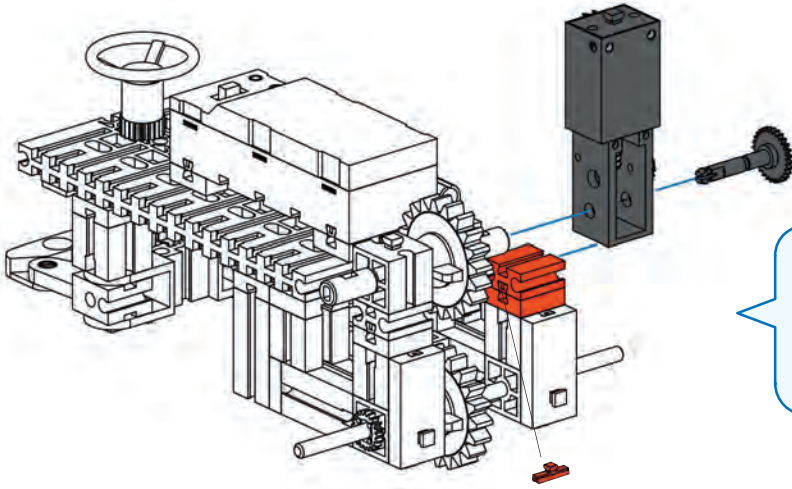

- 9**
- 1x [Motor]
 - 1x [Motor]
 - 1x [Screw]
 - 1x [Pin]
 - 1x [Bracket]
 - 1x [Bracket]

- 10** 38 x [Pin]

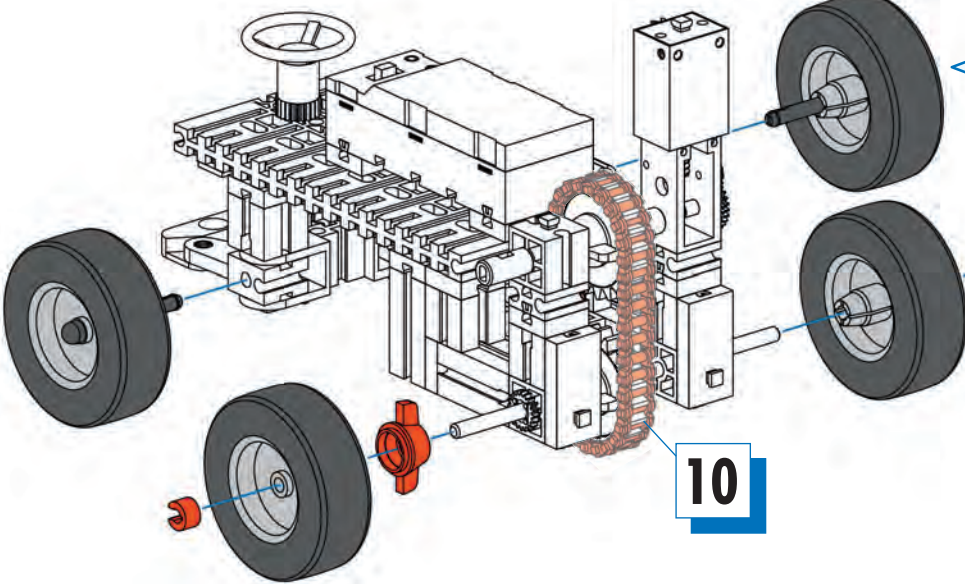

- 11**
- 4x [Wheel]
 - 2x [Pin]
 - 1x [Bracket]
 - 2x [Screw]

10

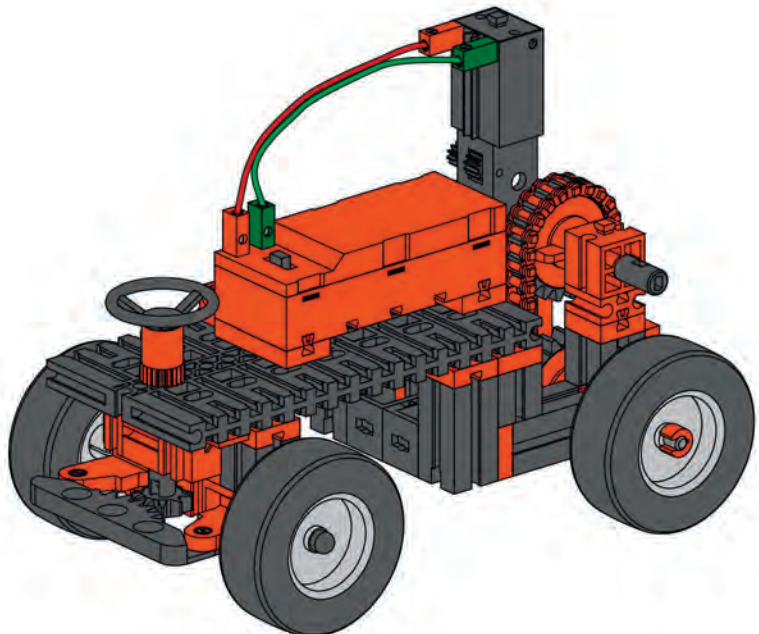



Bollerwagen
Handcart
Chariot à main

Bolderkar
Carro
Carrinho de puxar

Carretto
Тележка
儿童手拉车

1

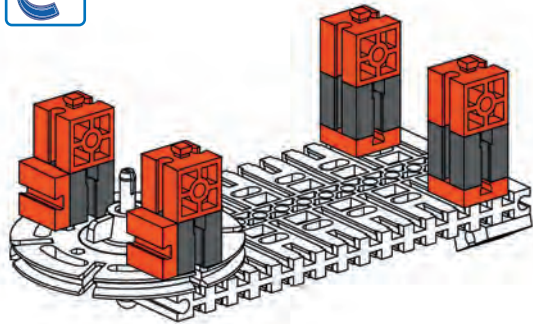
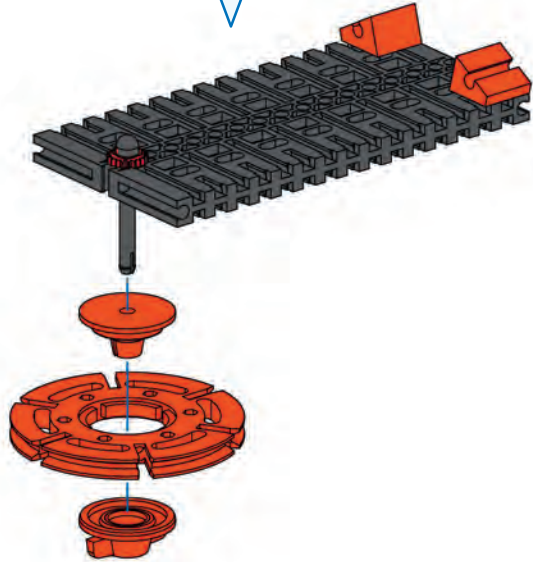

2

3

60 mm

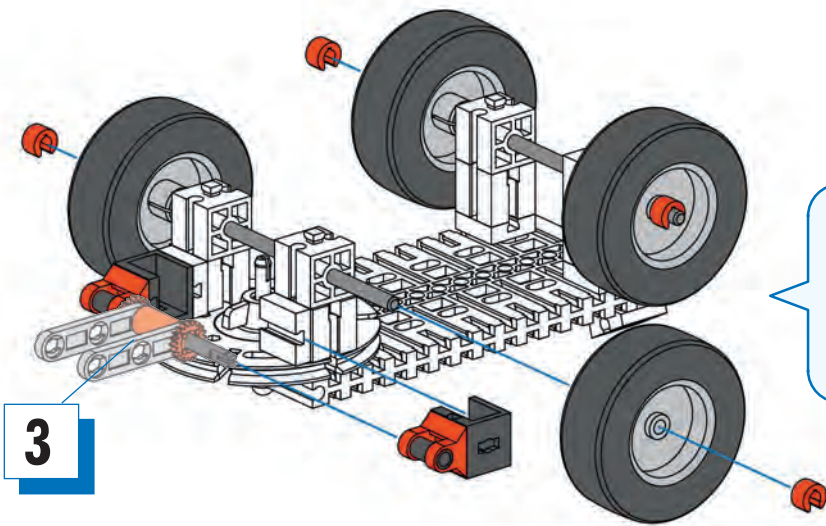
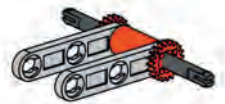

4

110 mm

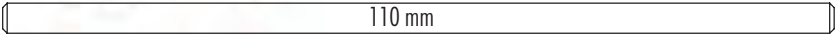

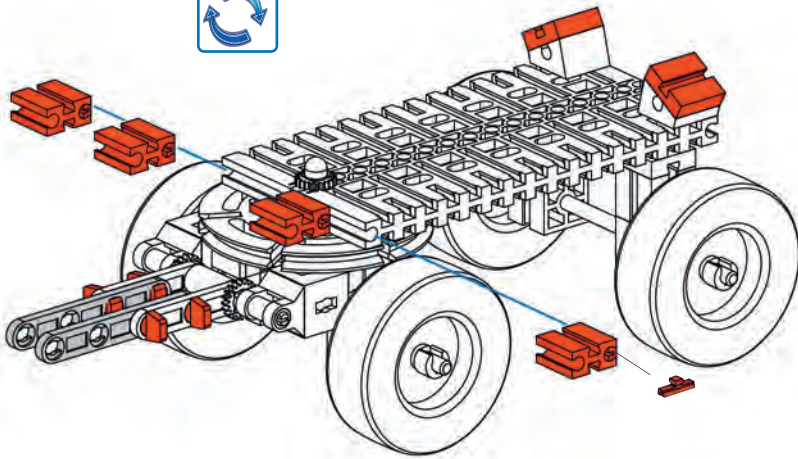

- 5**
- 4 x [Orange 1x2 Technic Brick]
 - 4 x [Orange 1x2 Technic Brick with Hole]
 - 2 x [Orange 1x2 Technic Brick with Hole]
 - 4 x [Red 1x2 Technic Pin]
 - 2 x [Grey 1x45 Technic Beam]

- 6**
- 2 x [Grey 1x90 Technic Beam]
 - 2 x [Grey 1x120 Technic Beam]
 - 2 x [Grey 1x75 Technic Beam]
 - 2 x [Orange 1x30 Technic Brick]
 - 4 x [Grey 1x4 Technic Connector]
 - 1 x [Grey 1x60 Technic Beam]
 - 2 x [Orange 30° Technic Bump]
 - 2 x [Orange 1x2 Technic Brick]
 - 3 x [Red 1x2 Technic Pin]
 - 4 x [Red 1x2 Technic Pin]
 - 2 x [Grey 1x2 Technic Pin]
 - 12 x [Red 1x2 Technic Pin]

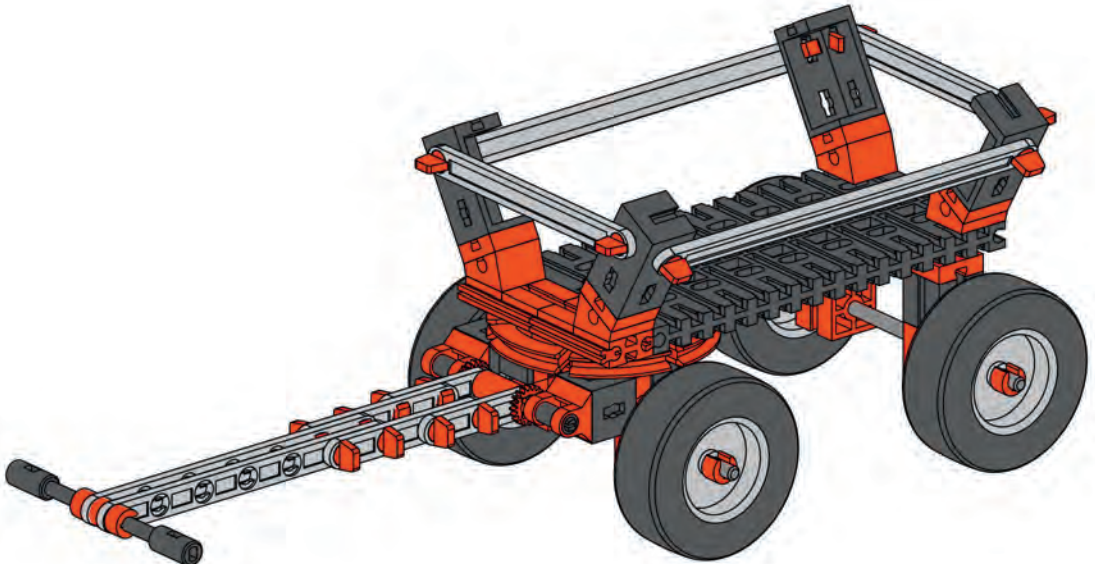
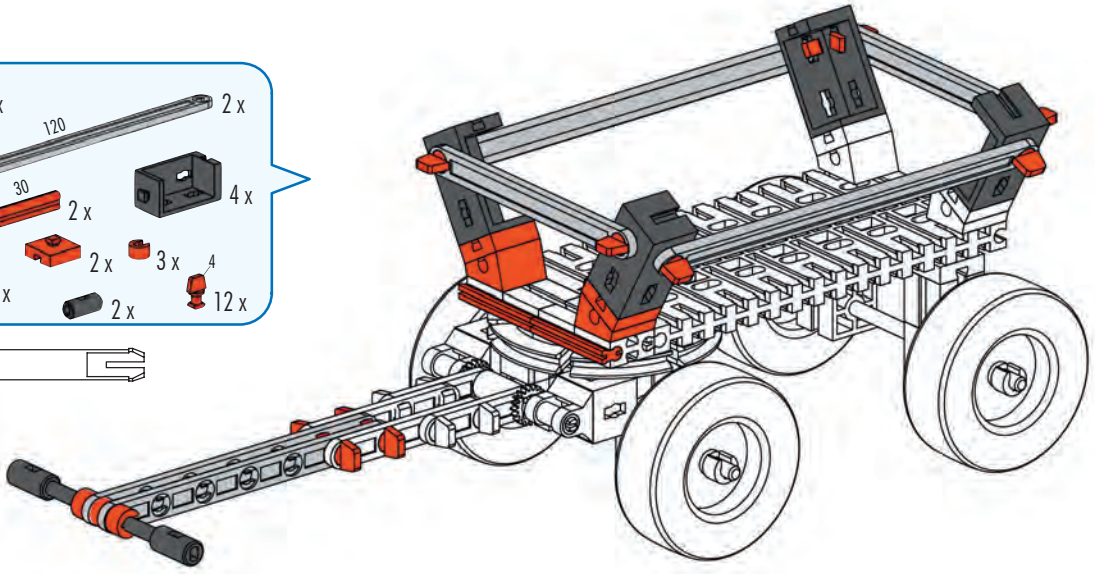
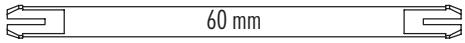

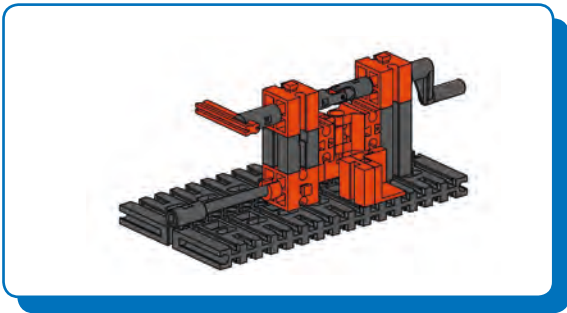

Kardangelenk
Cardan joint
Joint de cardan

Cardanoverbrenging
Articulación cardán
Junta universal

Giunto cardanico
Карданный шарнир
万向节

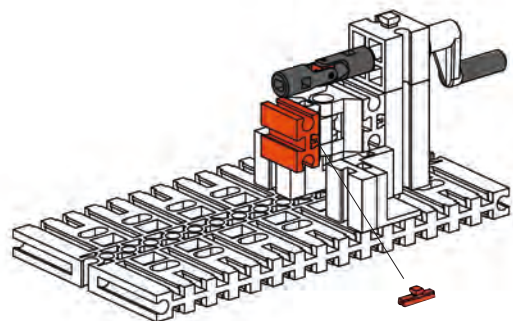
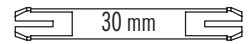
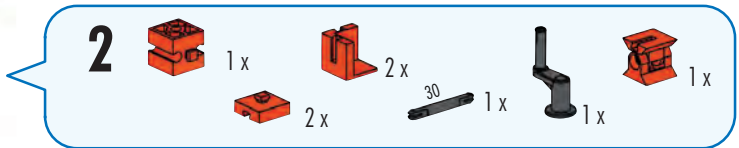
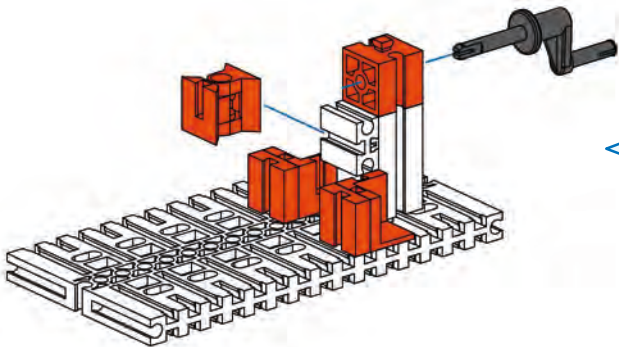
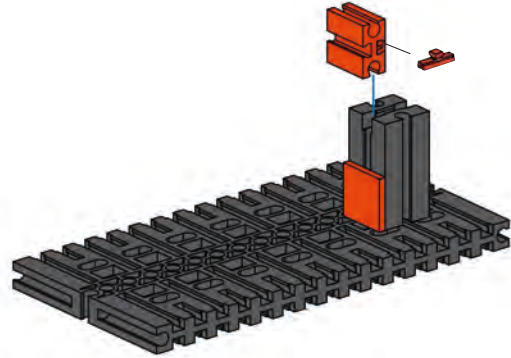
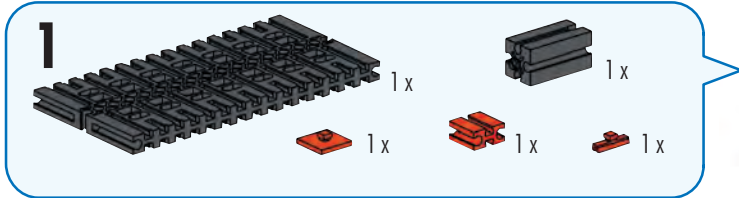

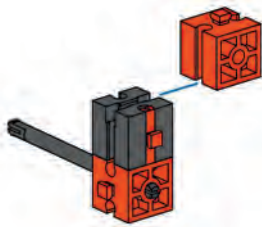

4 2x 1x 1x 1x 1x

45

45 mm

5 30 1x 1x 30 1x 1x 1x

30 mm

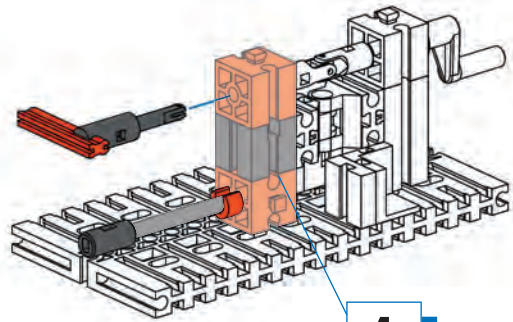

4

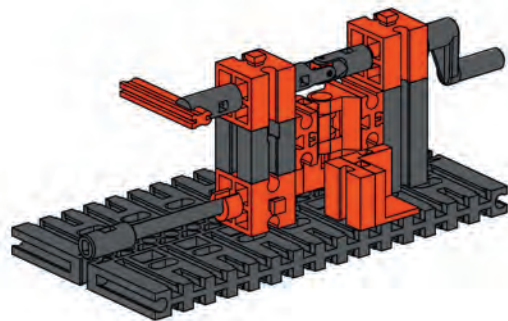

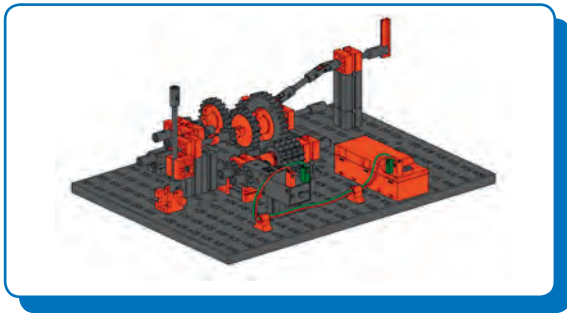

Schaltgetriebe
Gearbox
Mécanisme intermittent

Schakeloverbrenging
Cambio de velocidades
Caixa de câmbio

Cambio meccanico
Коробка передач
变速器

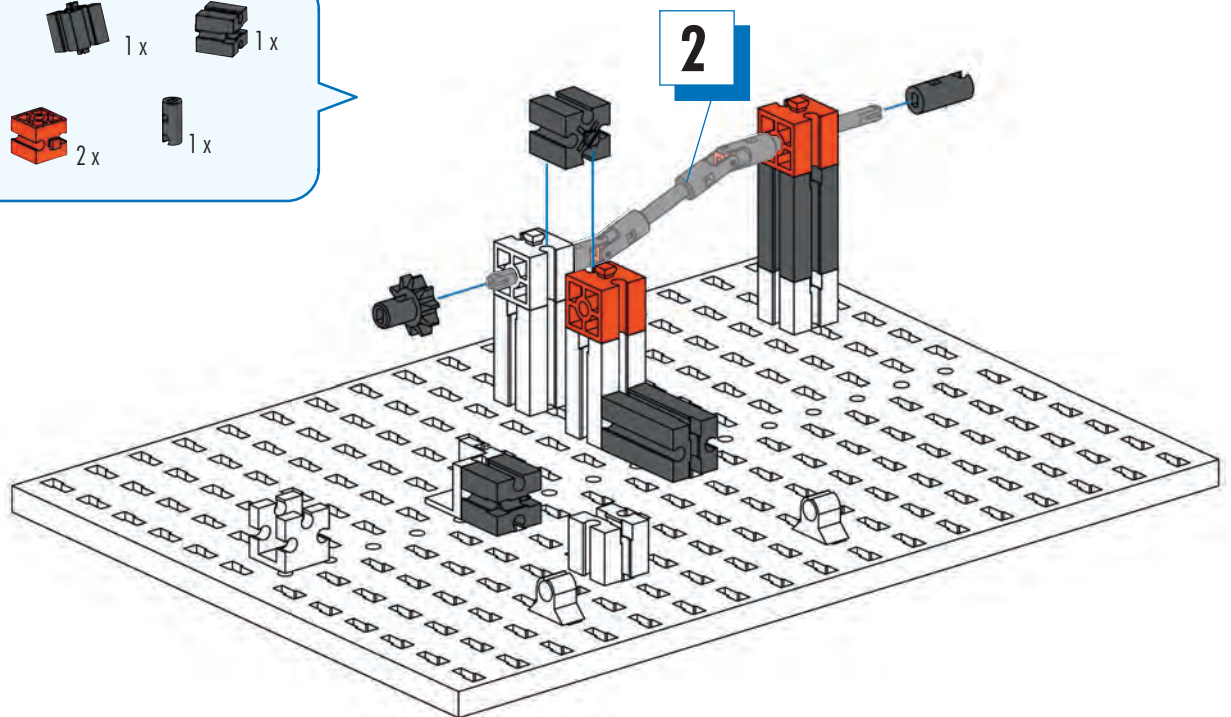
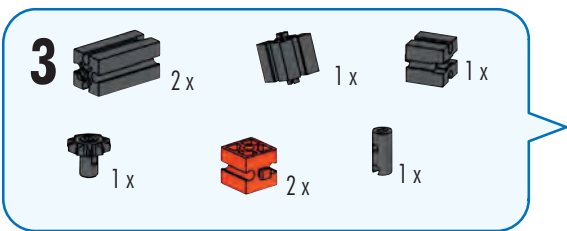
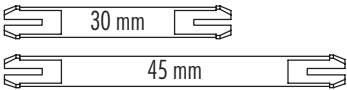
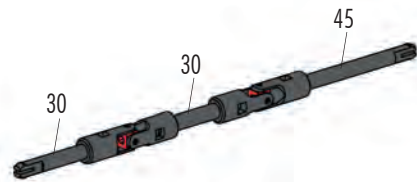
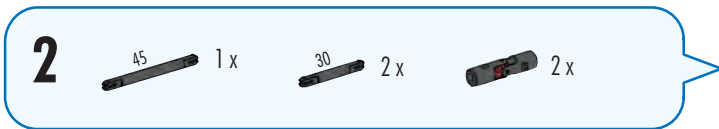
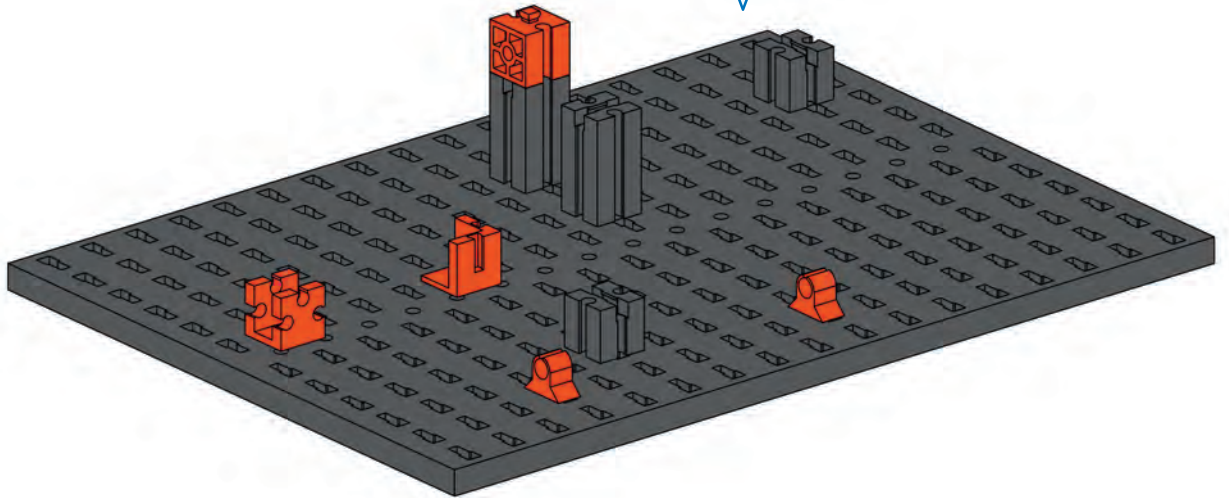
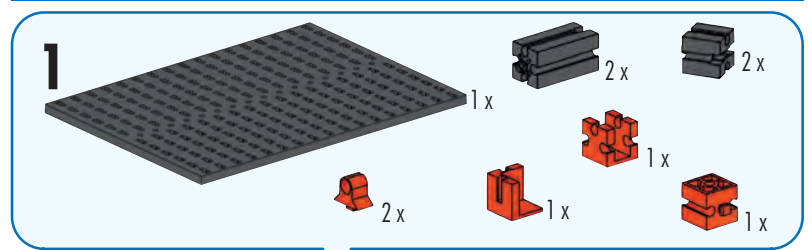

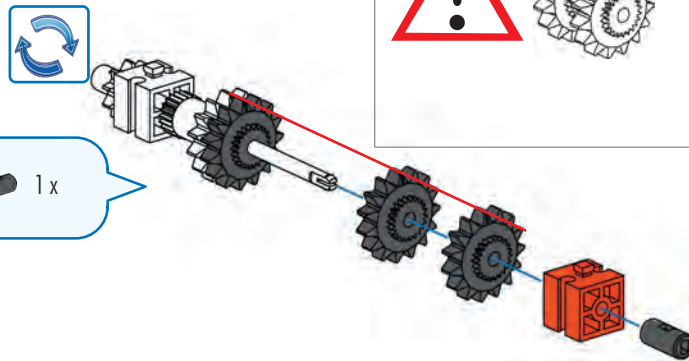
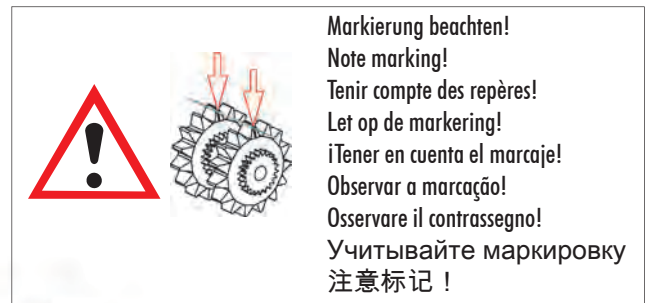
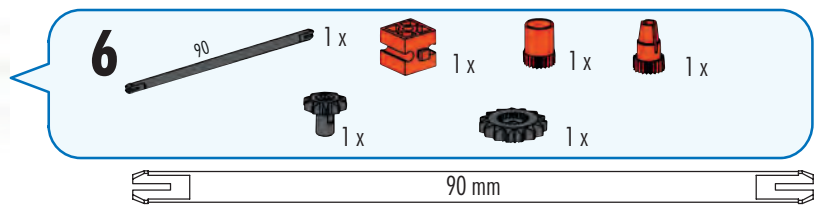
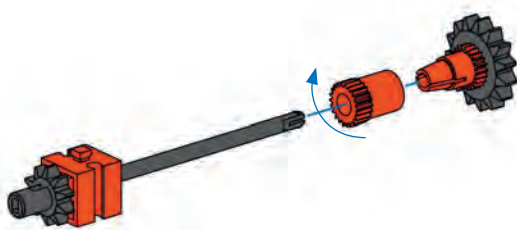
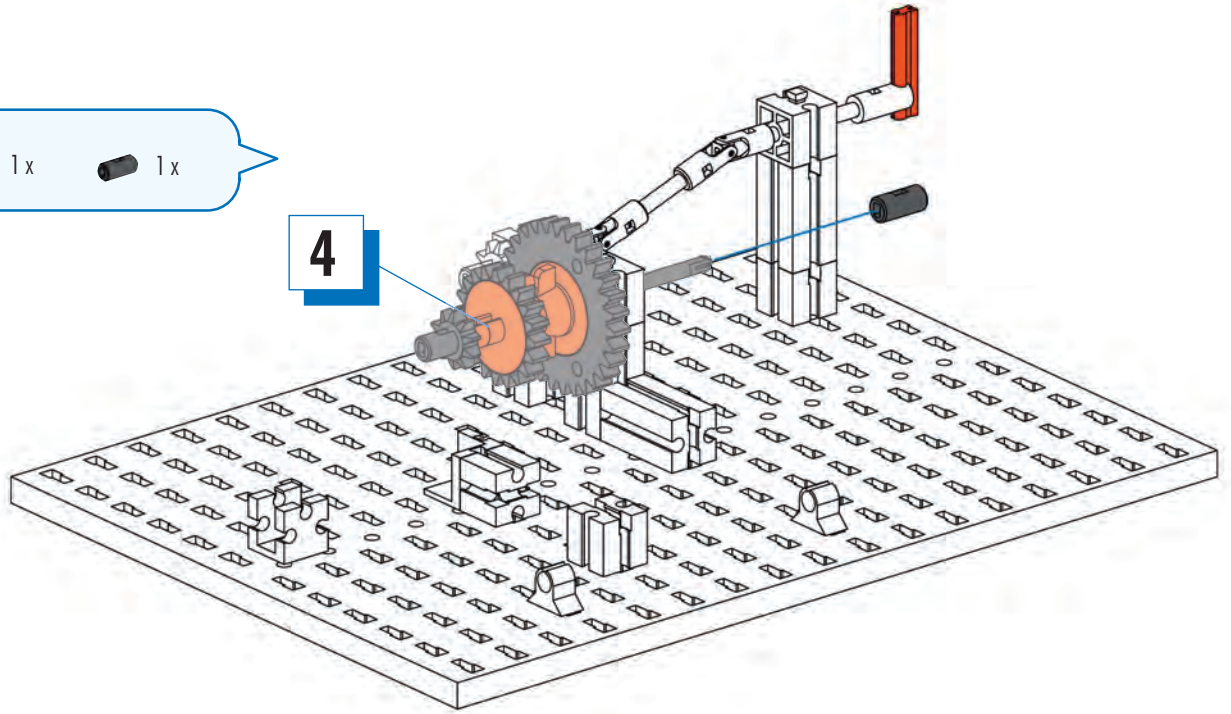
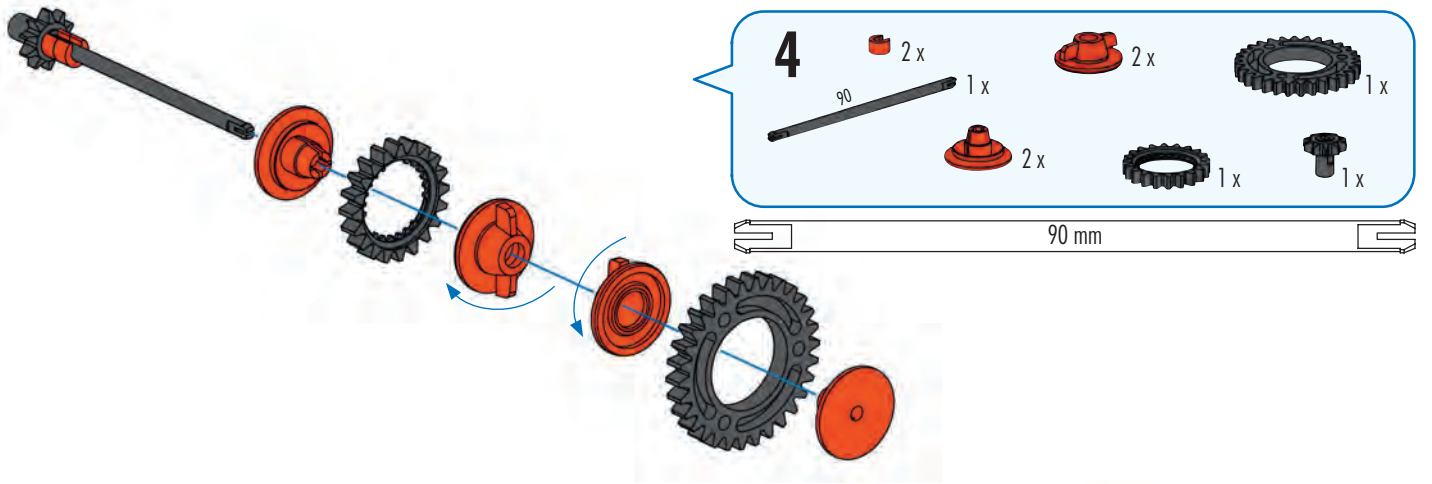

8

- 2 x 
- 1 x 
- 1 x 

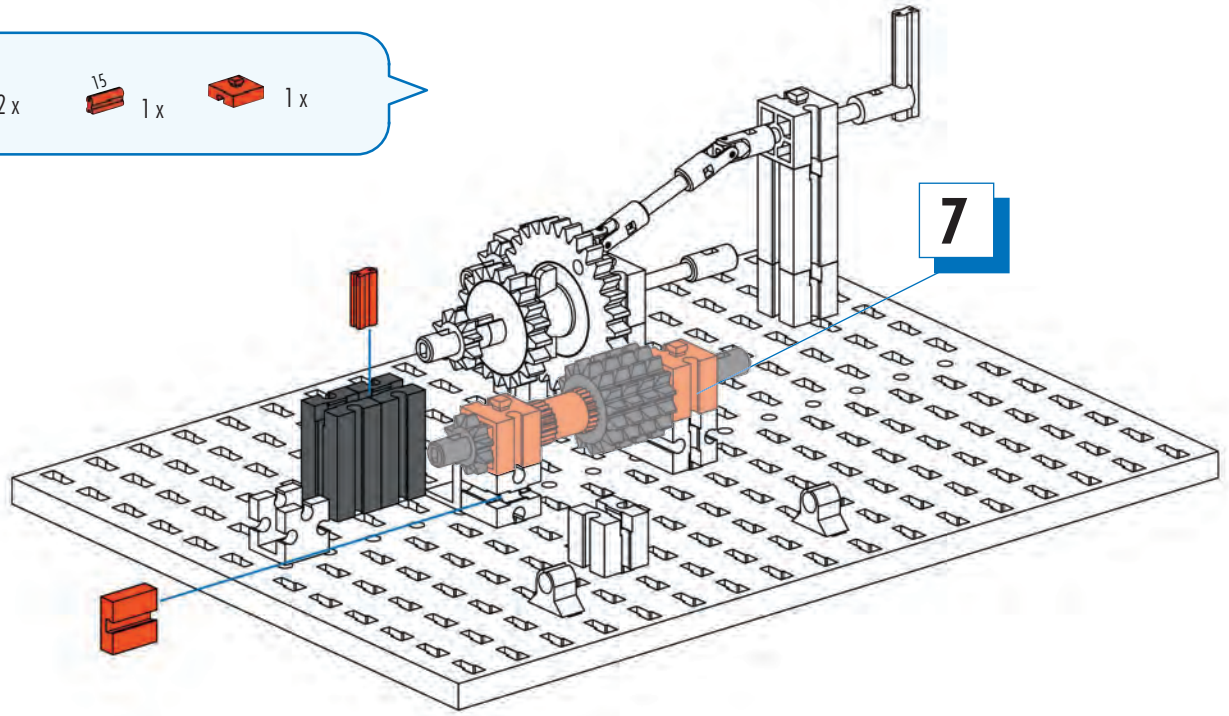

7

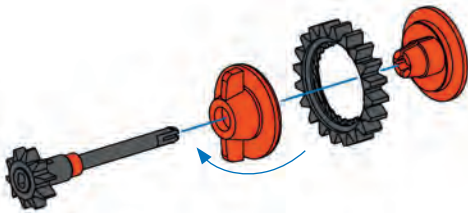

9

- 1 x 
- 1 x 
- 1 x 
- 1 x 
- 1 x 
- 1 x 

45 mm

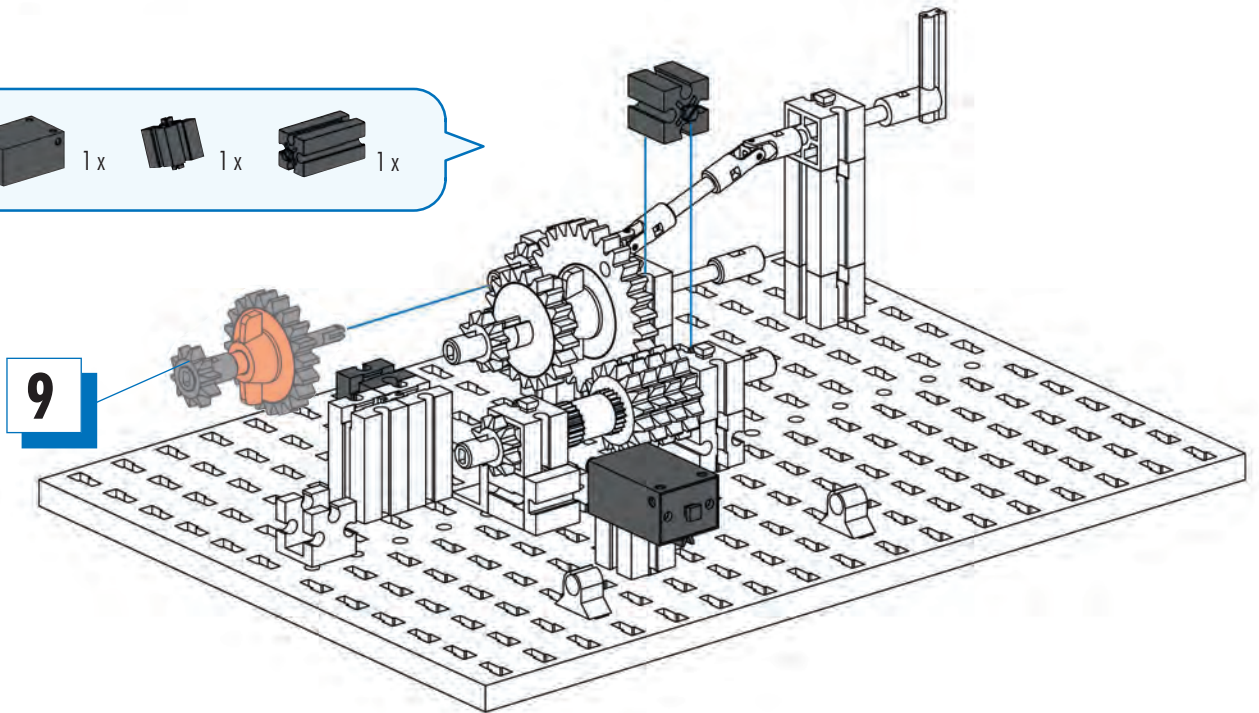

10

- 1 x 
- 1 x 
- 1 x 

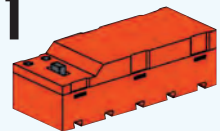

9

11

- 1 x 
- 4 x 

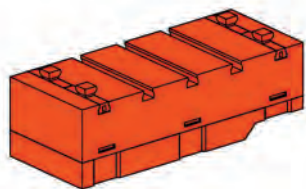

12

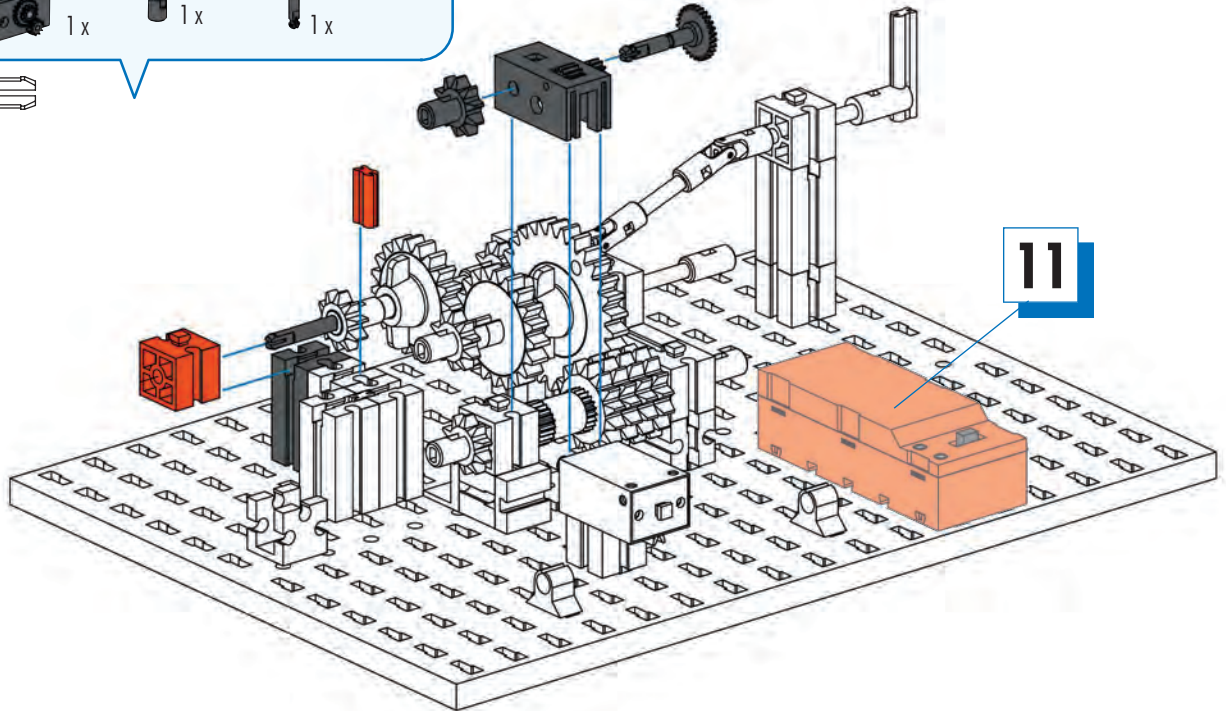
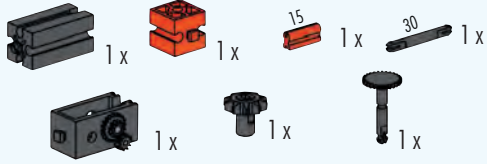

11

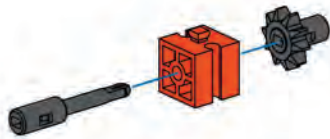

13

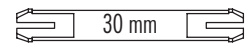

14

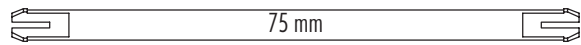
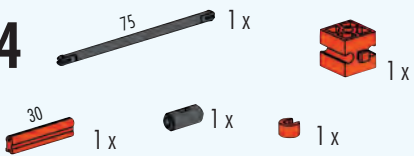

13

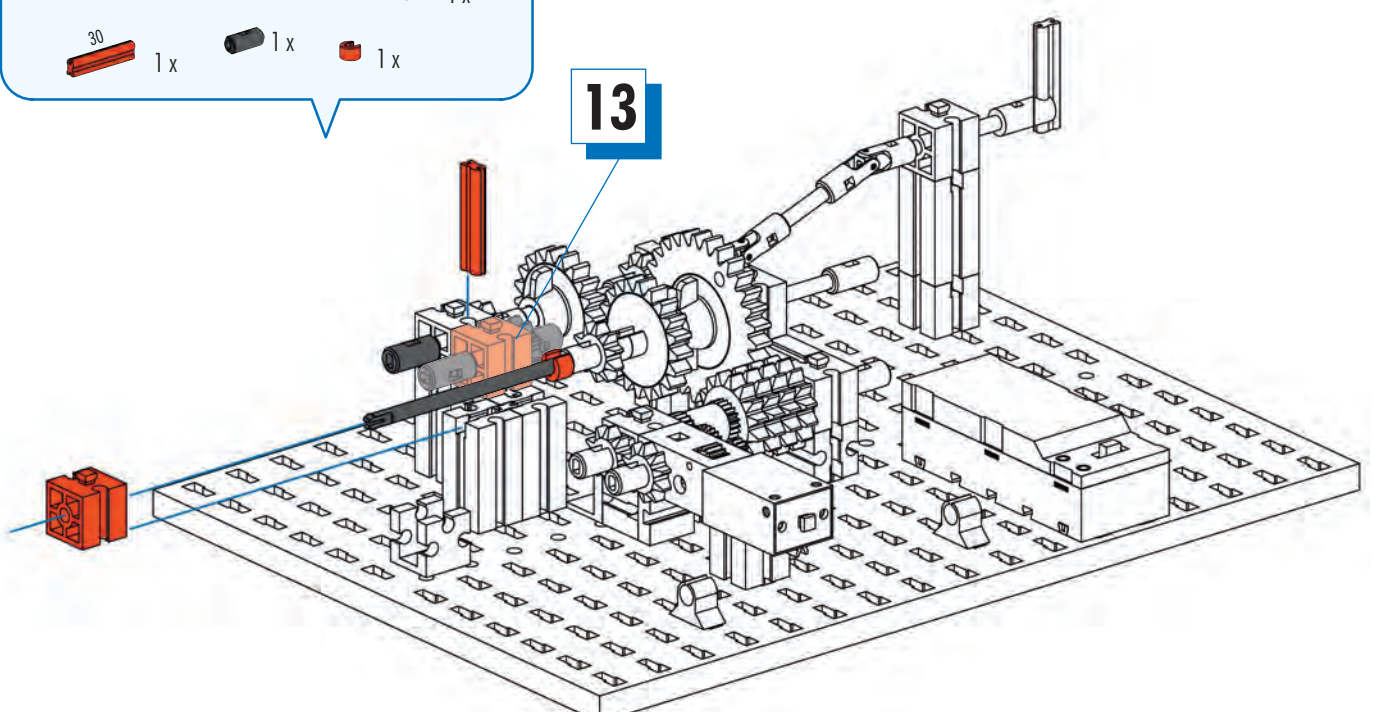

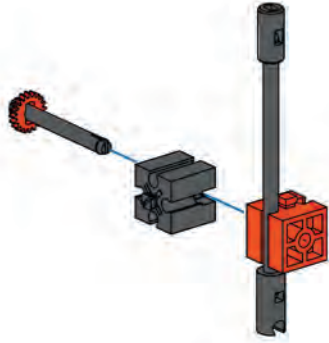

15

- 1x grey Technic connector
- 1x red Technic block
- 1x grey axle
- 1x black axle pin
- 1x grey axle pin
- 1x black axle pin
- 1x black axle pin (75)

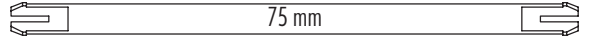

16

- 1x red axle pin
- 1x black axle pin
- 1x red Technic block

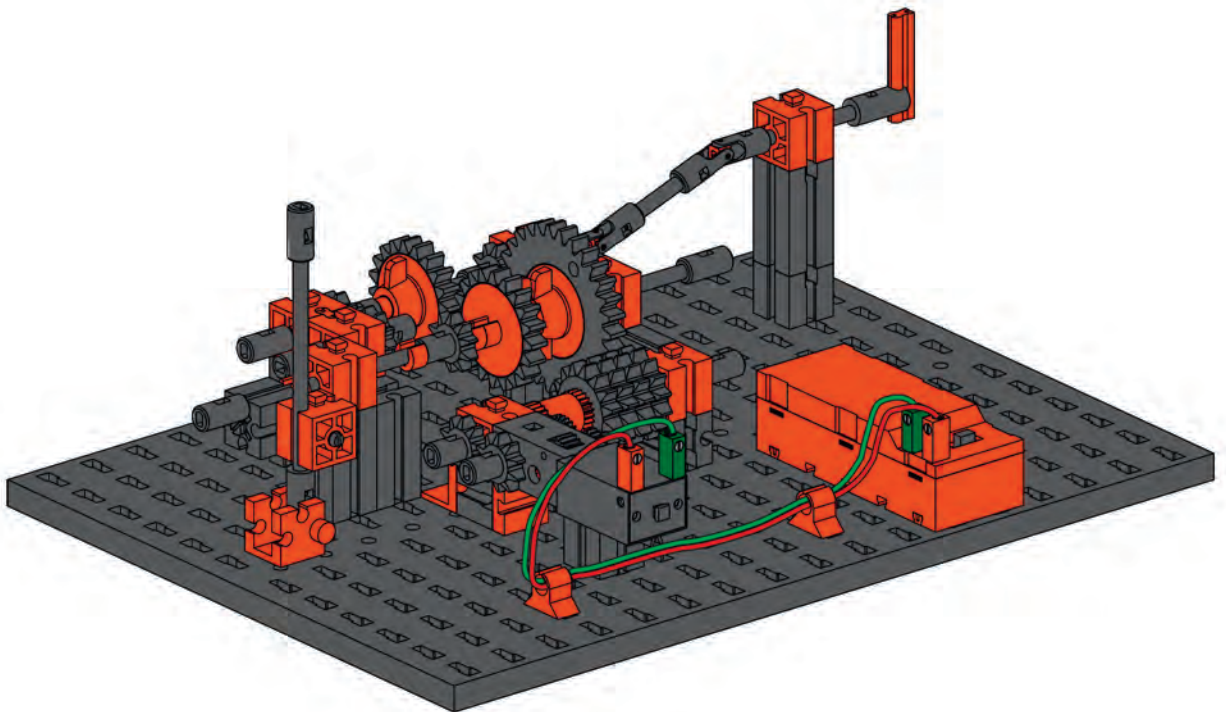
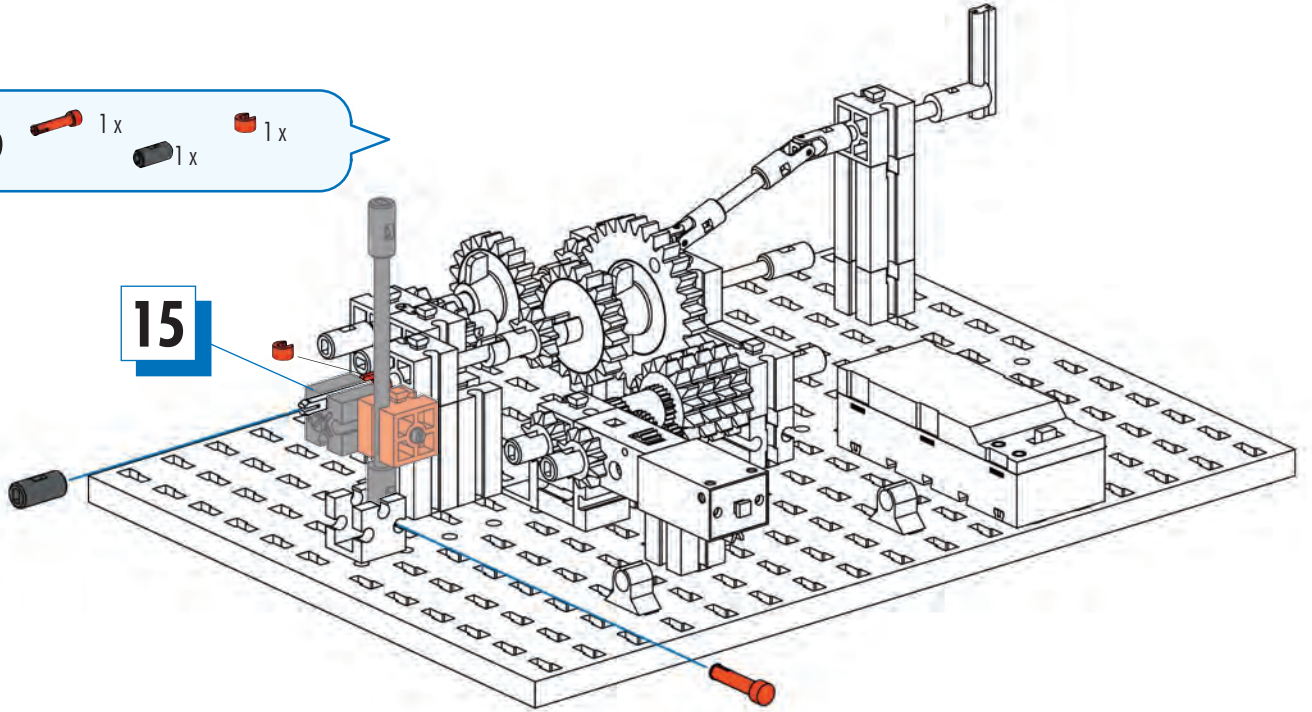

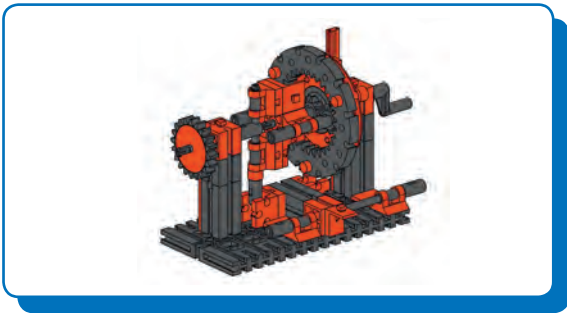



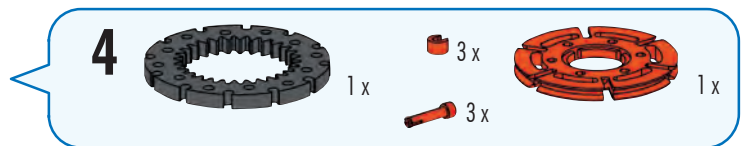
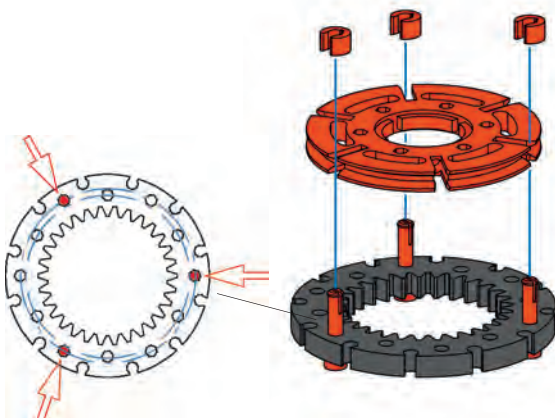
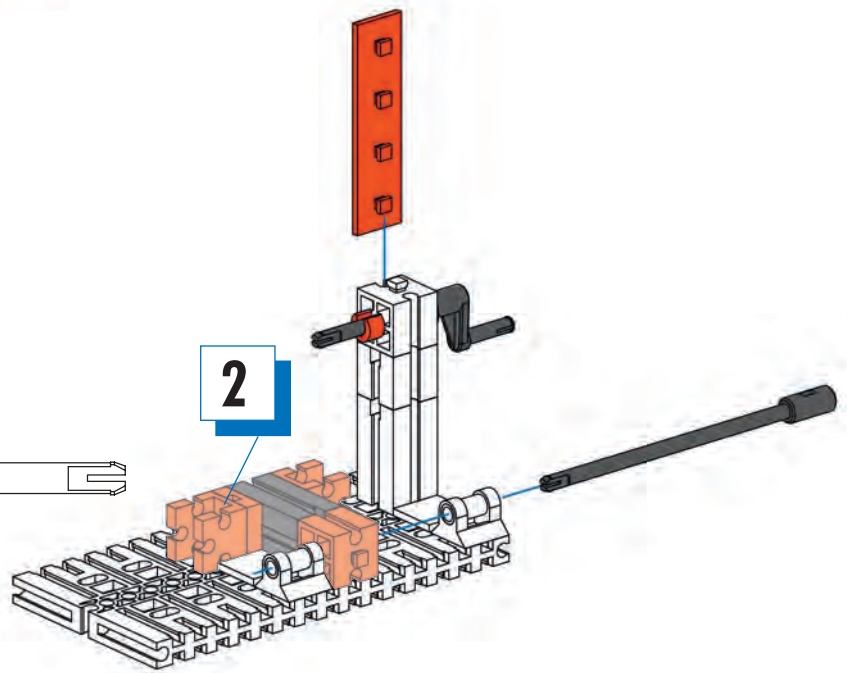
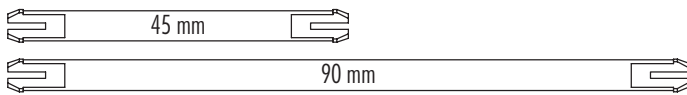
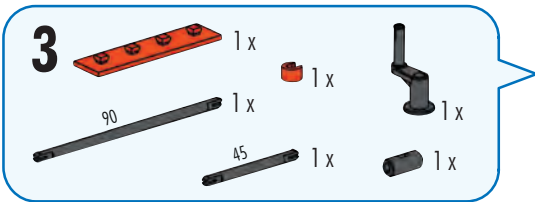
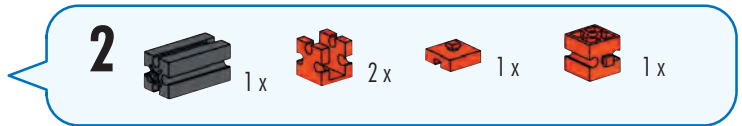
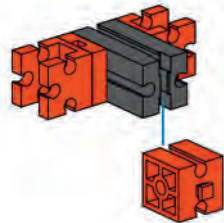
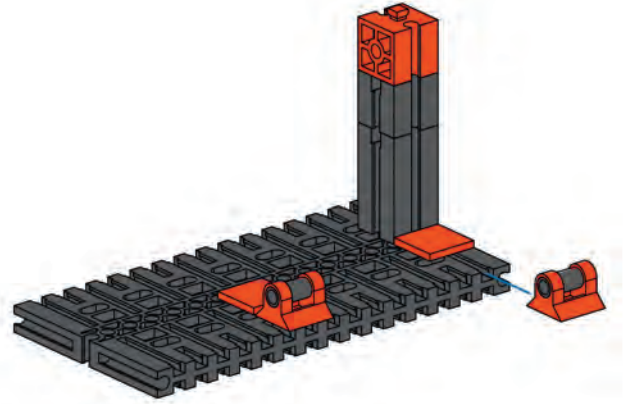
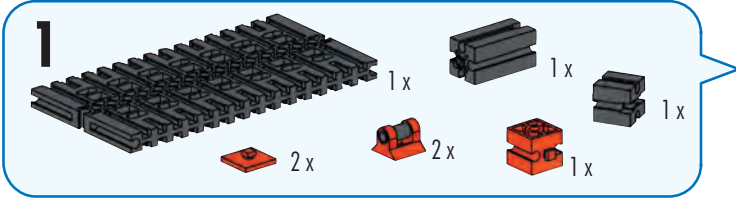

Planetengetriebe
Planetary gear
Engrenage planétaire

Planeetwieloverbrenging
Engranaje planetario
Engrenagem planetária

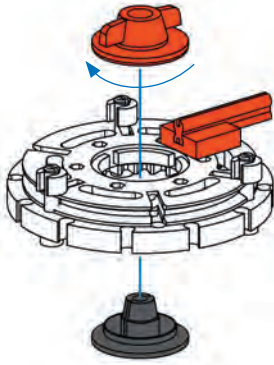



Rotismo epicicloidal
Планетарный редуктор
行星齿轮机构



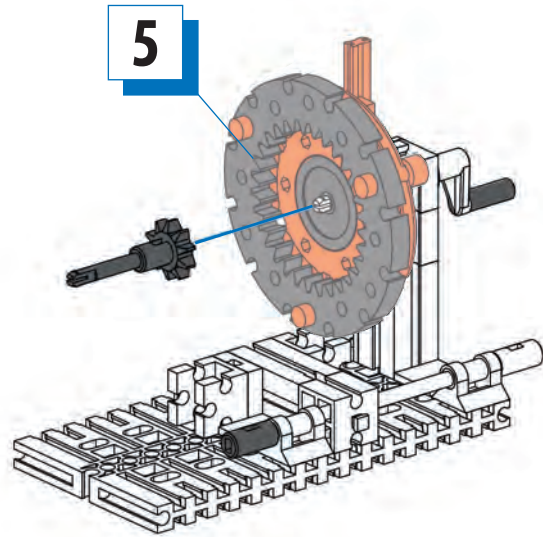





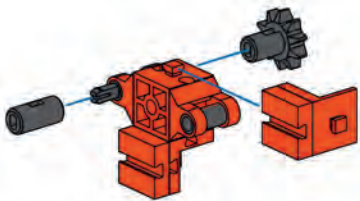
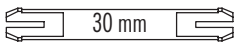

5  1x  1x  1x  1x







6  1x  1x  1x  1x





7  1x  2x  2x  1x  1x  1x



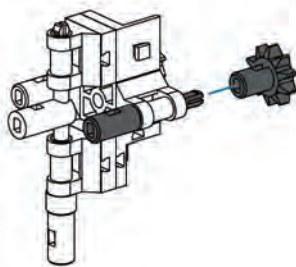
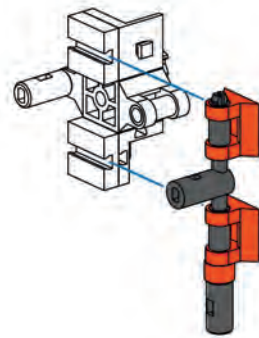
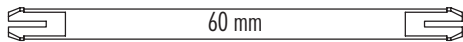

8  2x  1x  1x  1x





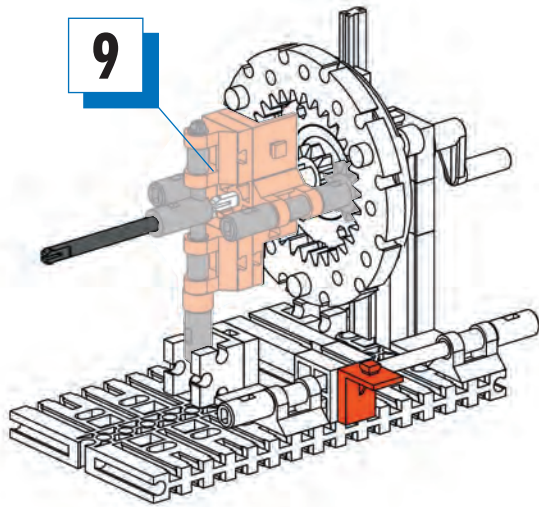

9  1x  1x  1x



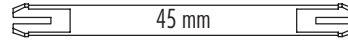



10  1x  1x



11  1x  1x  1x  1x

 1x  1x  1x

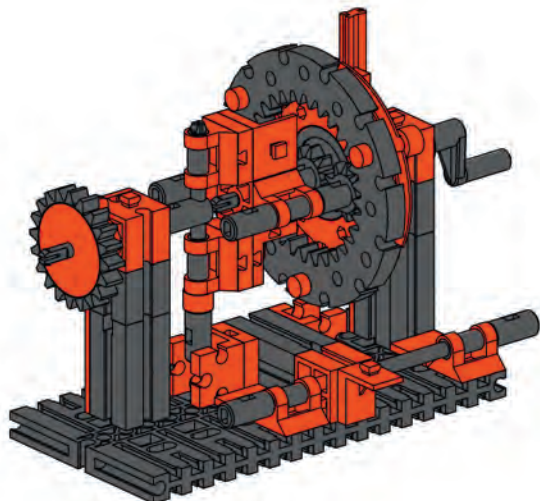
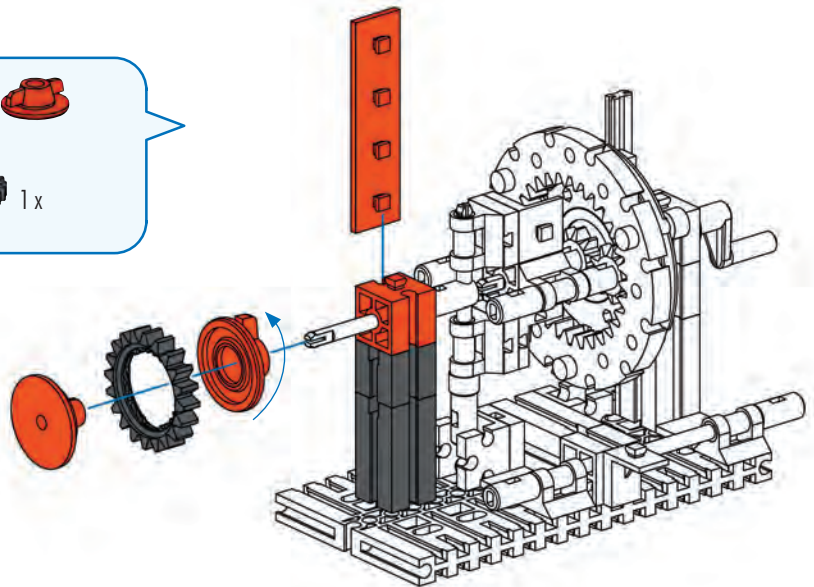

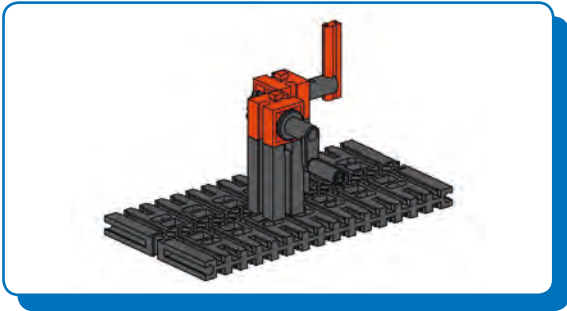

Kegelradgetriebe
Bevel gear
Engrenage à pignon conique

Conische tandwieloverbrenging
Engranaje de ruedas cónicas
Engrenagem cônica

Ingranaggio conico
Конический редуктор
锥齿轮传动机构

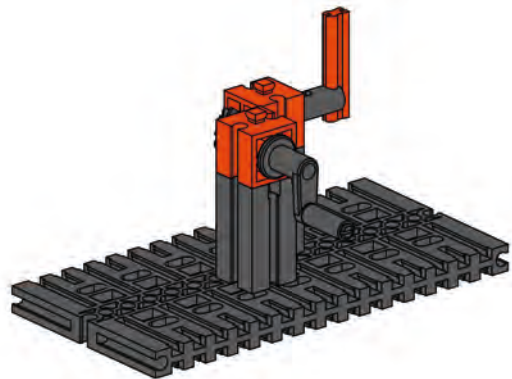
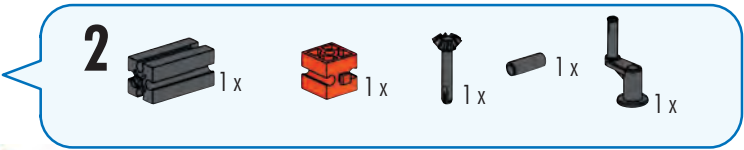
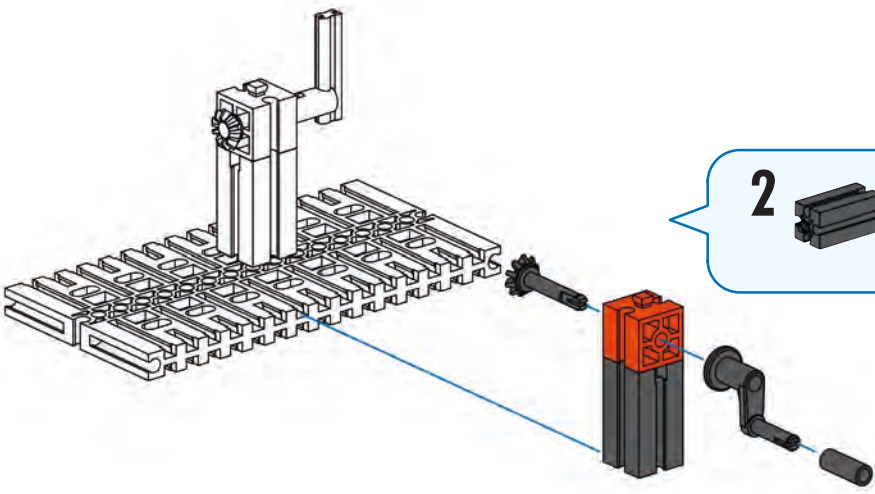
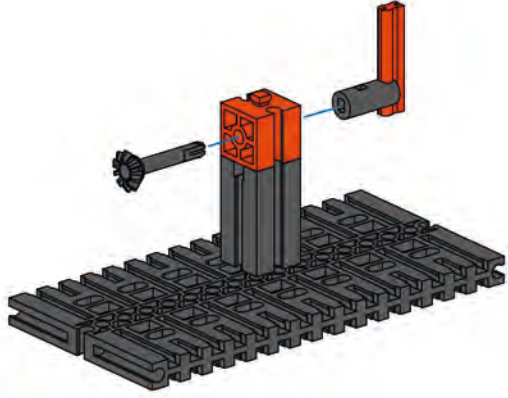
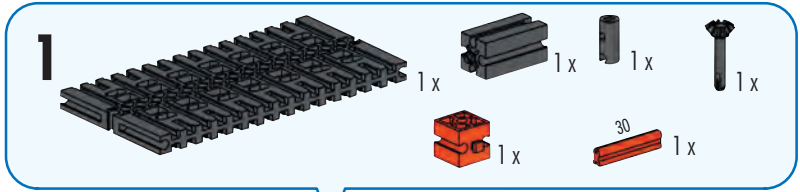

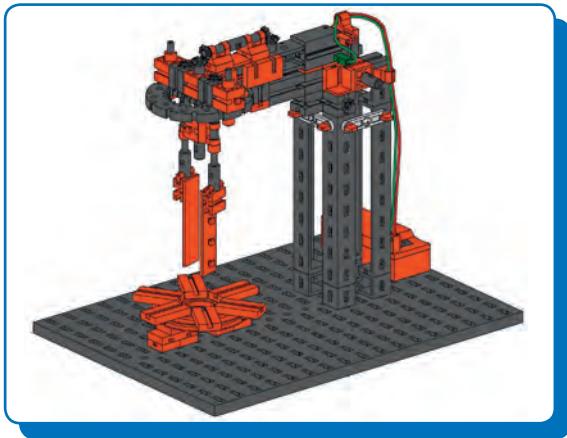

Küchenmaschine
Kitchen appliance
Robot ménager

Keukenmachine
Máquina de cocina
Máquinas de cozinha

Robot da cucina
Кухонный комбайн
电动厨具

1

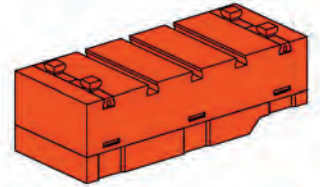
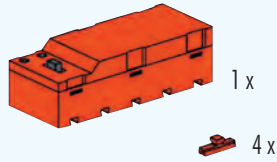

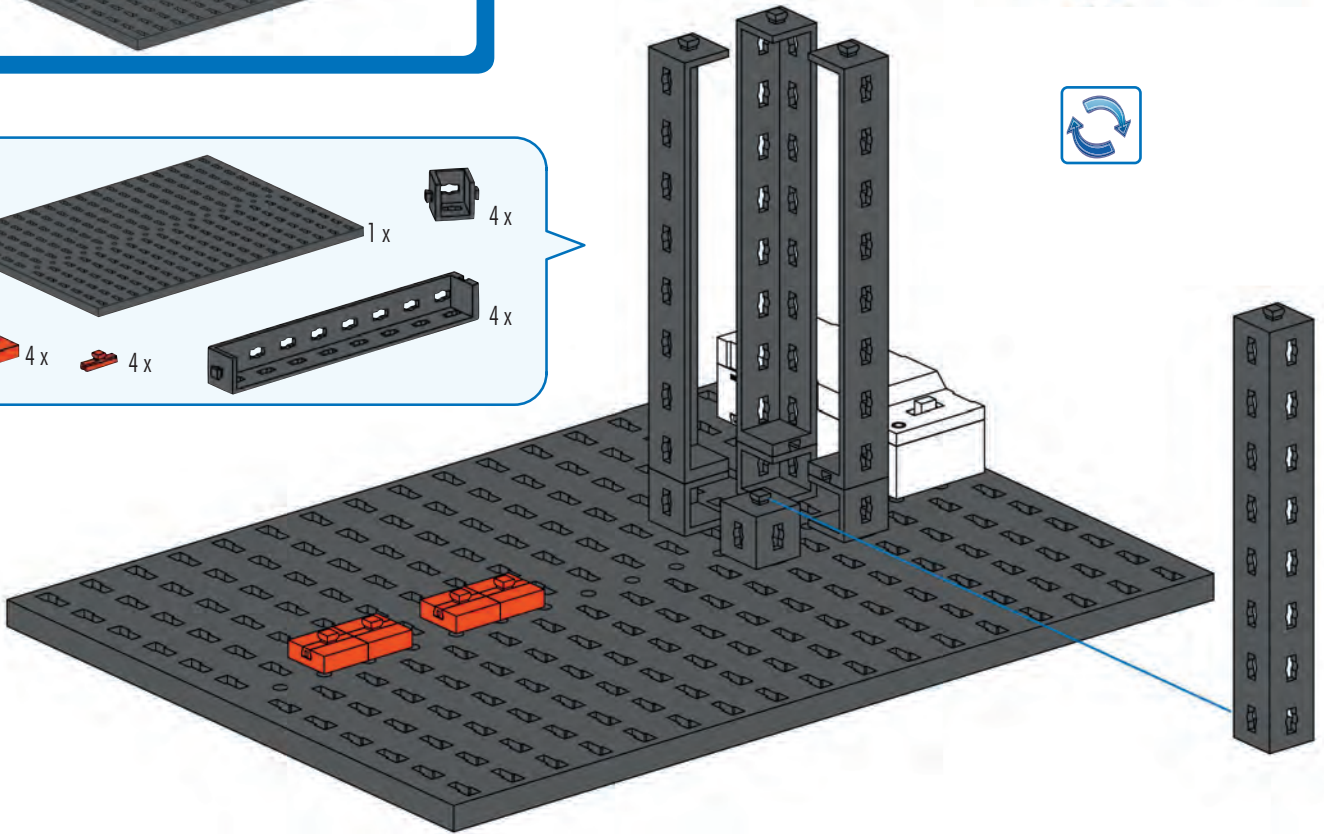
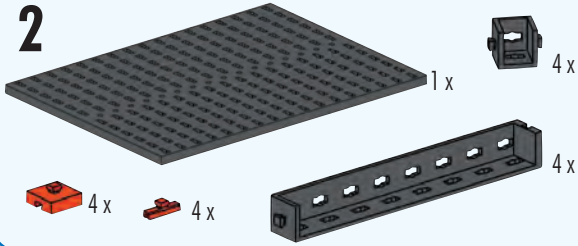

2



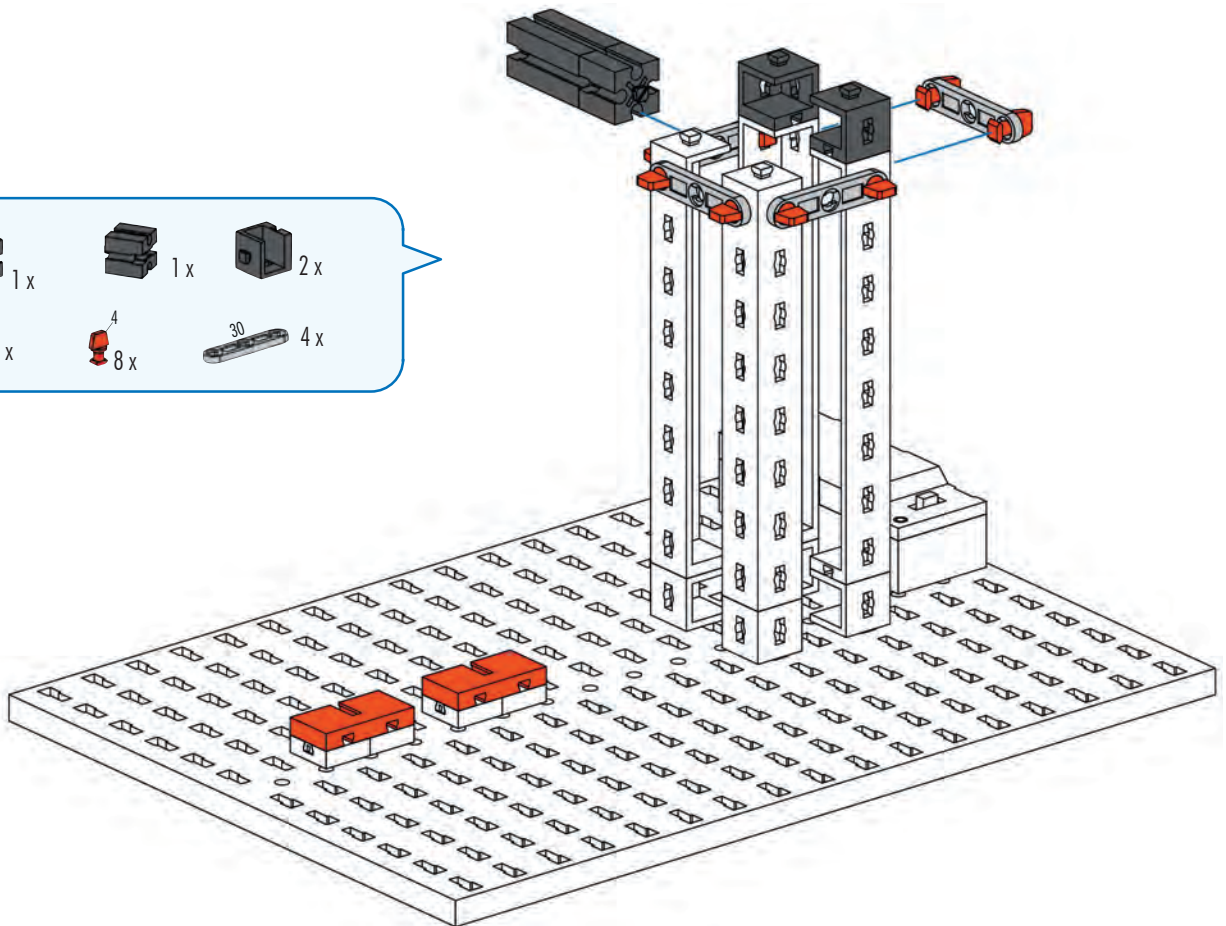
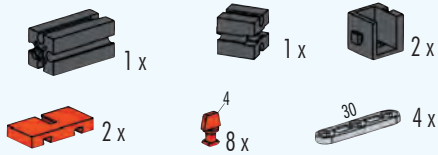

3









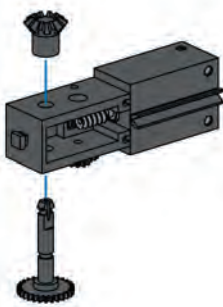
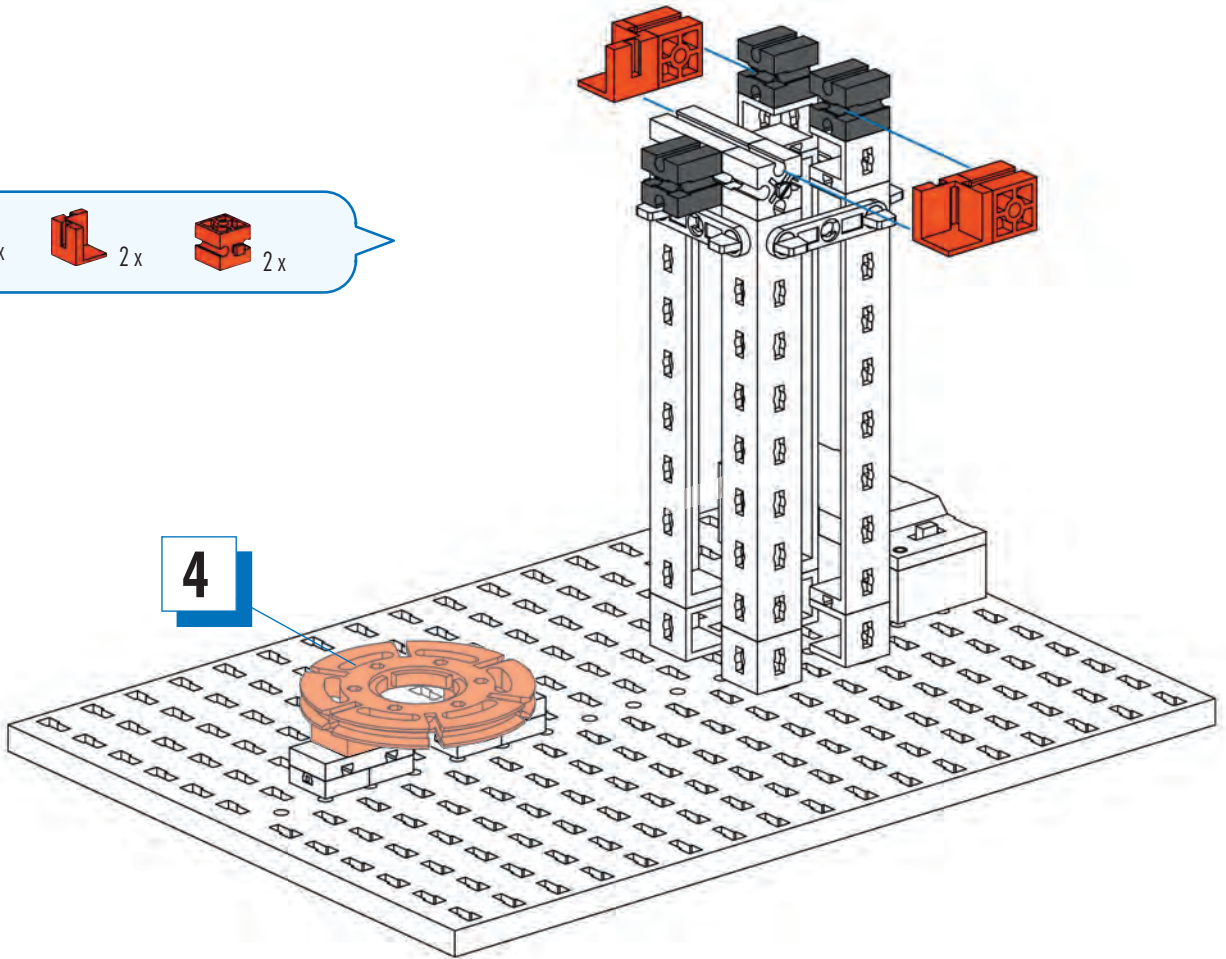



4  1x  2x

5  3x  2x  2x



6  1x  1x  1x  1x

7  2x  1x  1x  2x

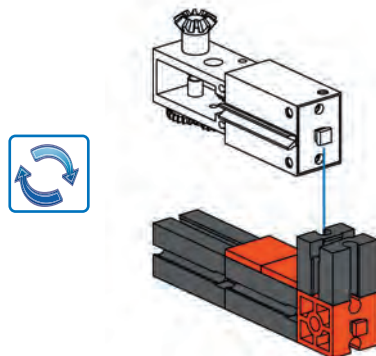

7

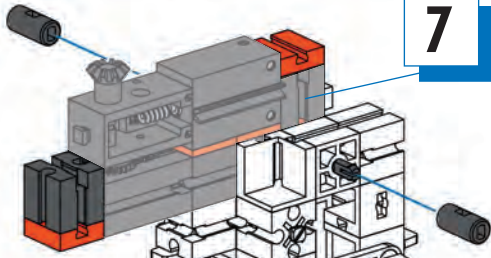

8

- 1 x [black 1x2 Technic brick]
- 2 x [red 1x2 Technic brick]
- 6 x [red 1x3 Technic brick]
- 1 x [black axle, length 60]
- 2 x [black axle pin]

60 mm

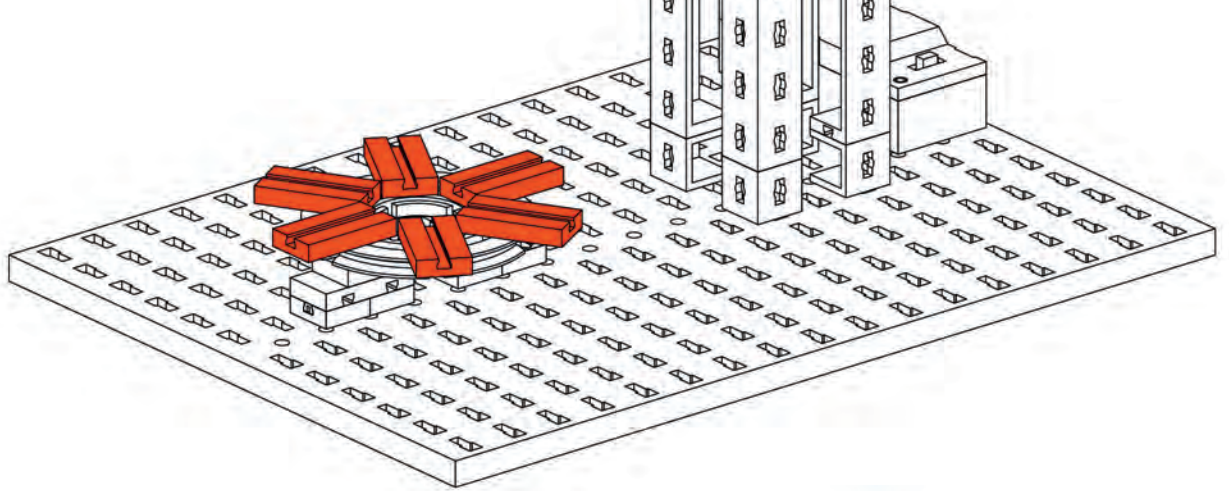

9

- 1 x [grey gear]
- 4 x [red axle pin]
- 2 x [red 1x2 Technic brick]
- 2 x [black axle, length 40]

40 mm

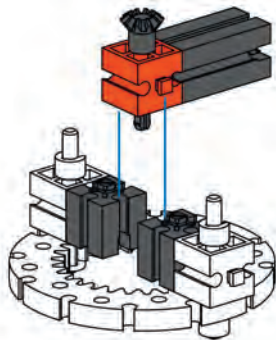
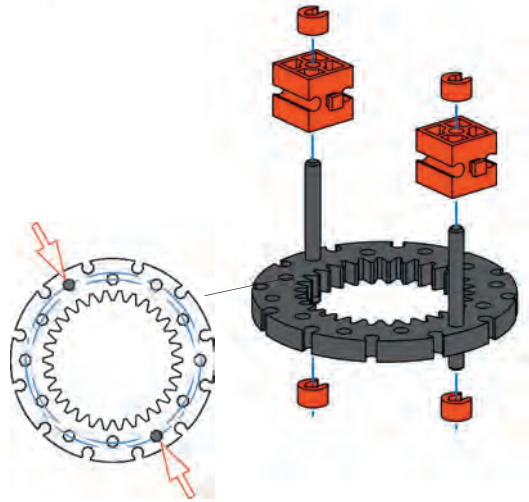

10

- 1 x [black 1x2 Technic brick]
- 2 x [black 1x2 Technic brick]
- 1 x [red 1x2 Technic brick]
- 1 x [black axle, length 30]
- 1 x [black axle pin]

30 mm

11

- 1x (red 1x2 Technic brick)
- 2x (black axle, length 45)
- 2x (red axle pin)
- 2x (black axle pin)
- 2x (black axle pin)

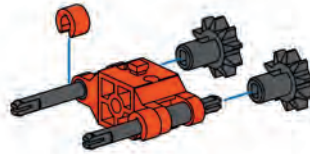

45 mm

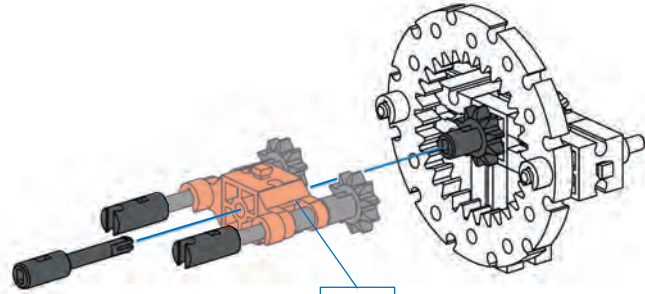

11

12

- 1x (black axle pin)
- 1x (black axle, length 30)
- 1x (black axle pin)
- 2x (black axle pin)

30 mm

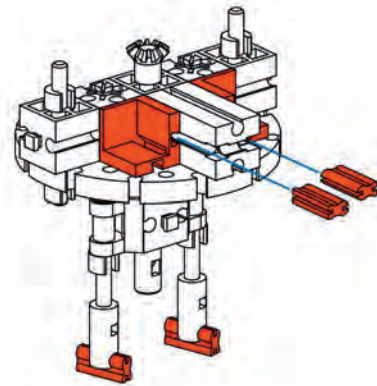

13

- 2x (red 1x2 Technic brick)
- 4x (red 1x2 Technic brick)

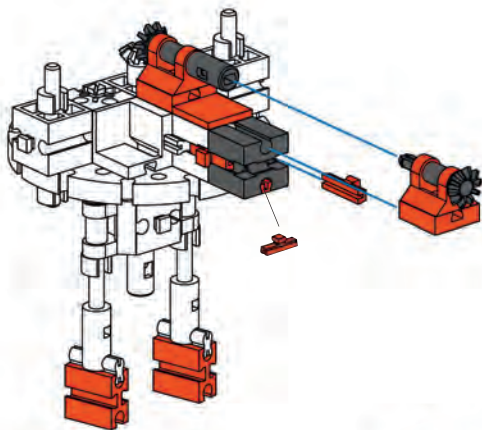

14

- 2x (red 1x2 Technic brick)
- 2x (red 1x2 Technic brick)
- 1x (black 1x2 Technic brick)
- 2x (black axle pin)
- 2x (red 1x2 Technic brick)
- 1x (red 1x2 Technic brick)
- 3x (red 1x2 Technic brick)
- 1x (black axle pin)

14

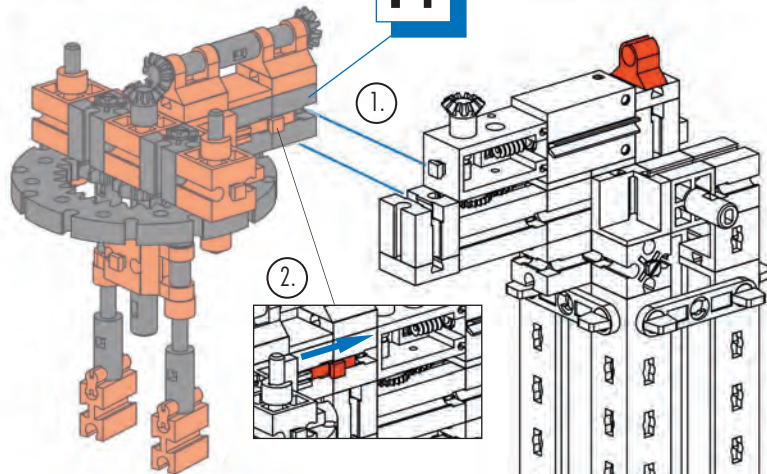

15

- 1x (red 1x2 Technic brick)

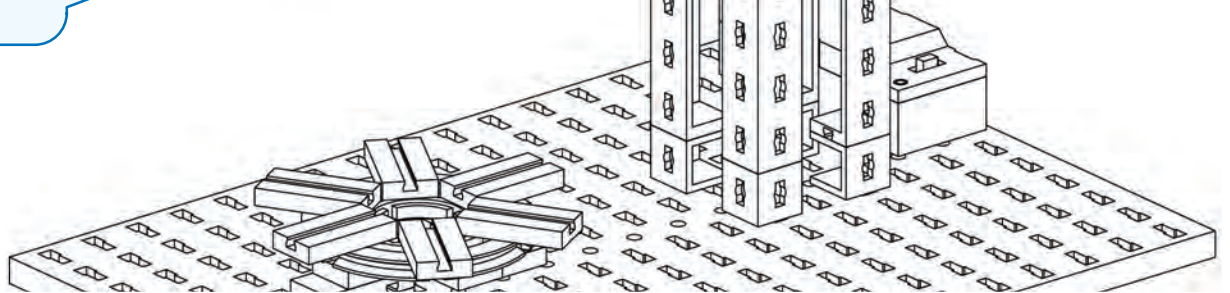

16  2x  2x  1x

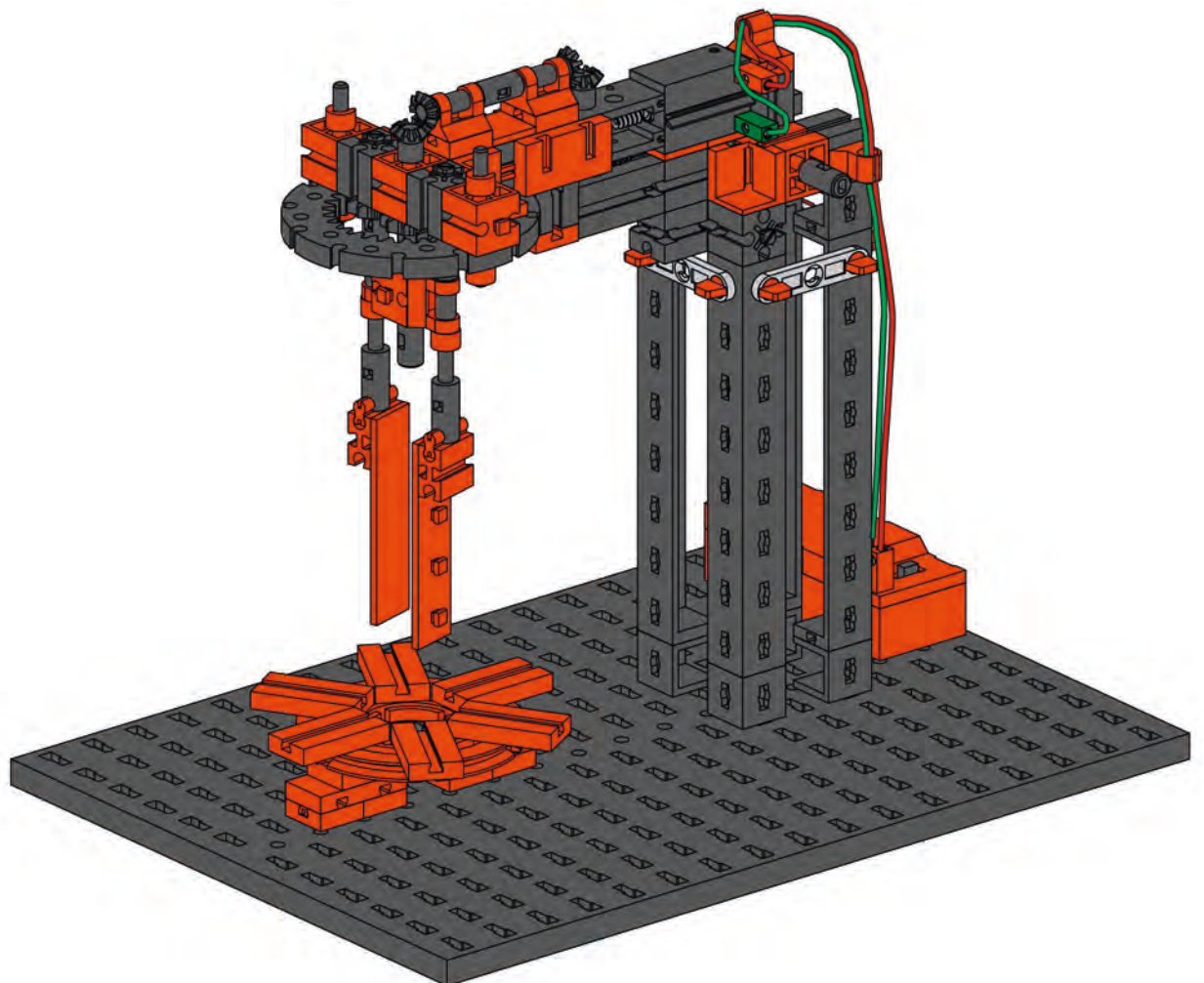
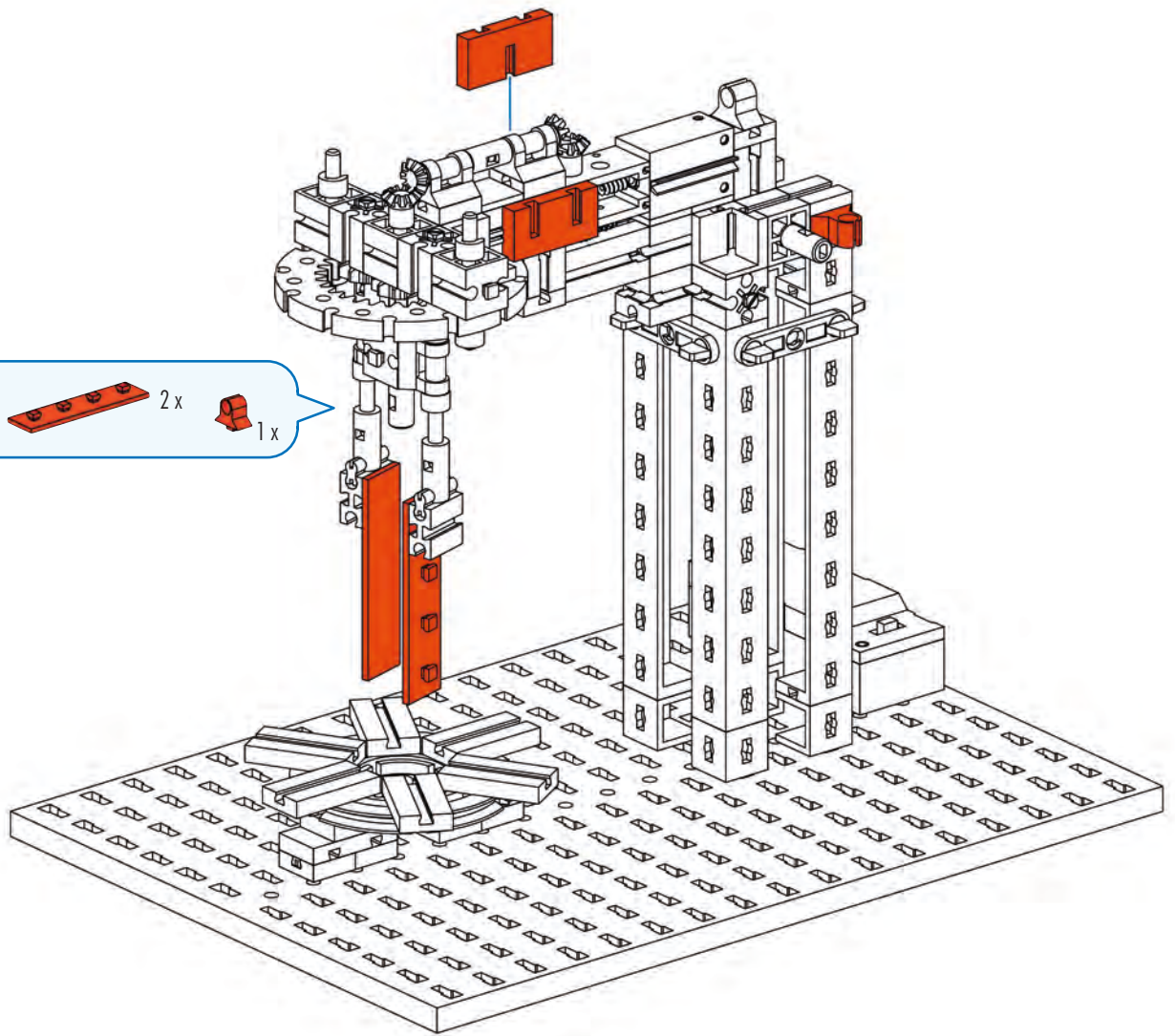

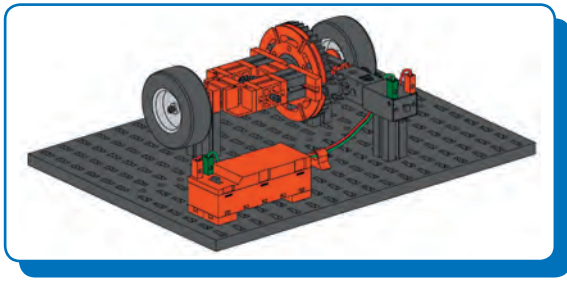

Differentialgetriebe
Differential gear
Engrenage différentiel

Differentiaal
Engranaje diferencial
Transmissão diferencial

Differenziale
Дифференциал
差速机构

1

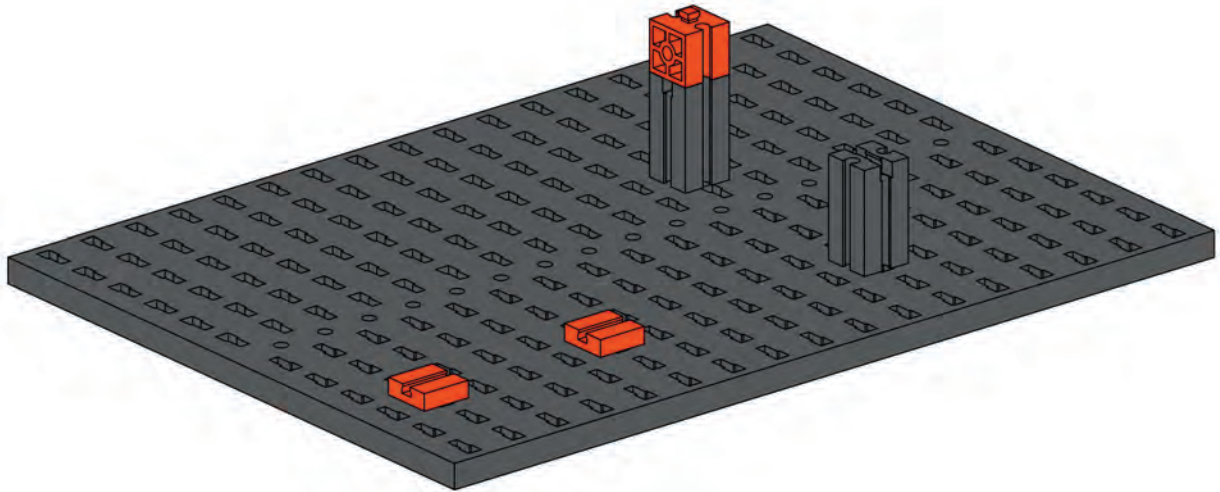

2

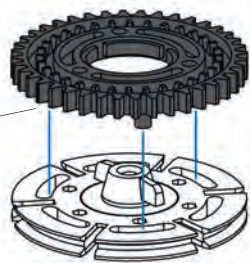
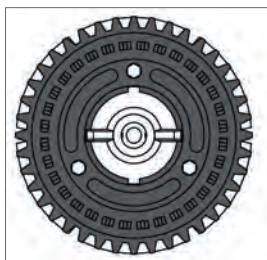
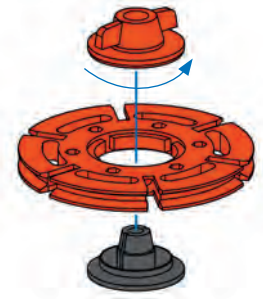

3

4

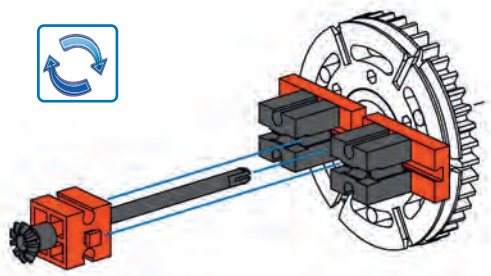
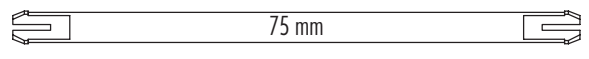

- 5** 1x 5x 2x 1x 1x 1x

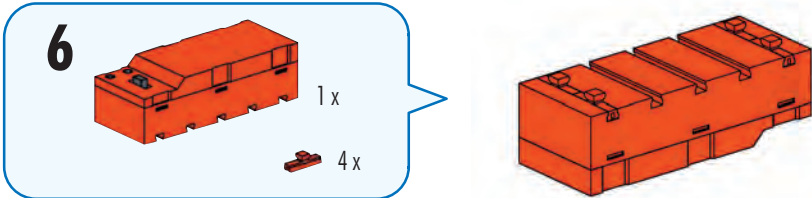
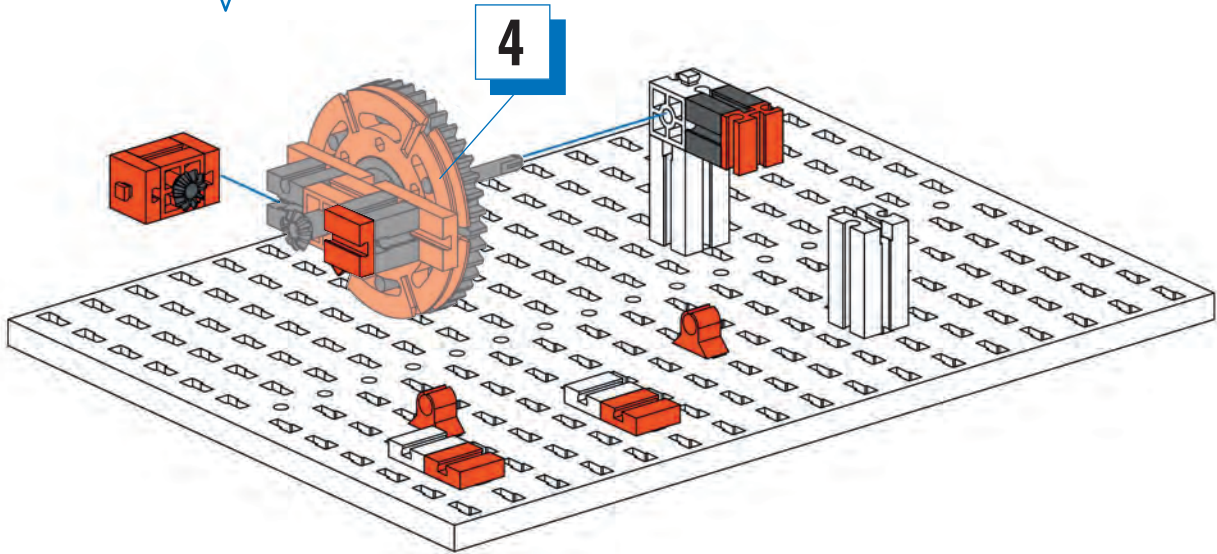

- 7** 1x 1x 1x 60 1x 1x 1x

60 mm

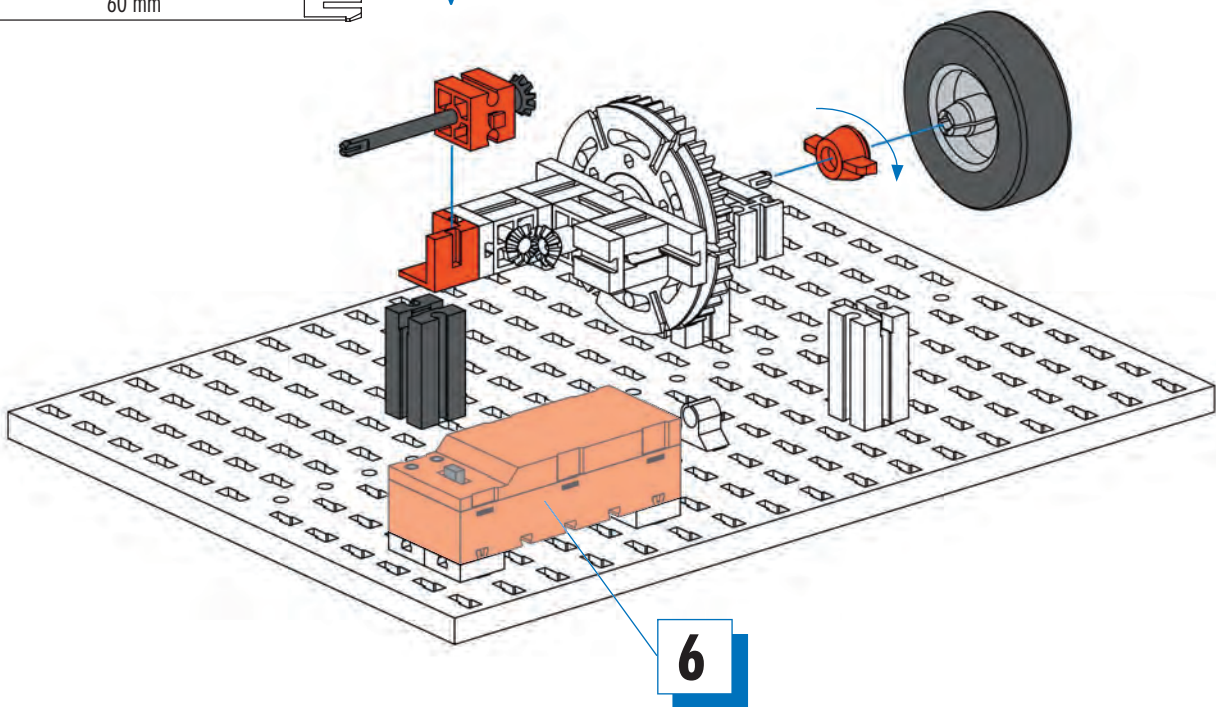

8



1x



1x



1x



1x



2x

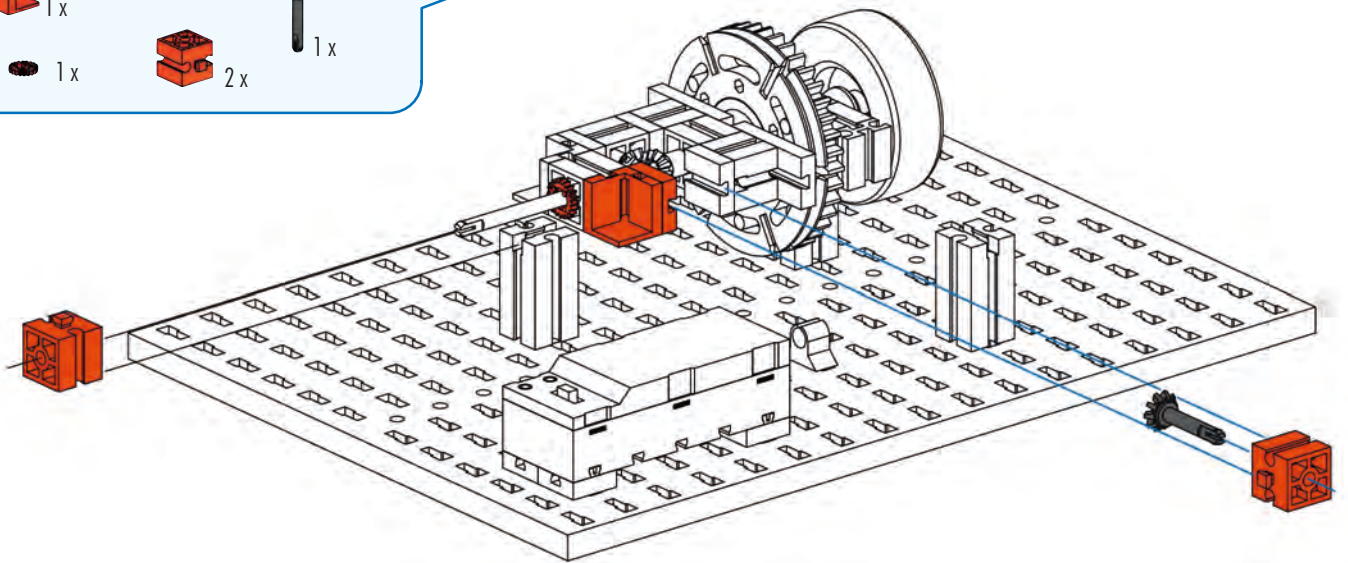

9

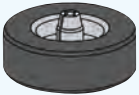

1x



1x



1x



1x



1x

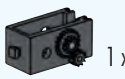

1x

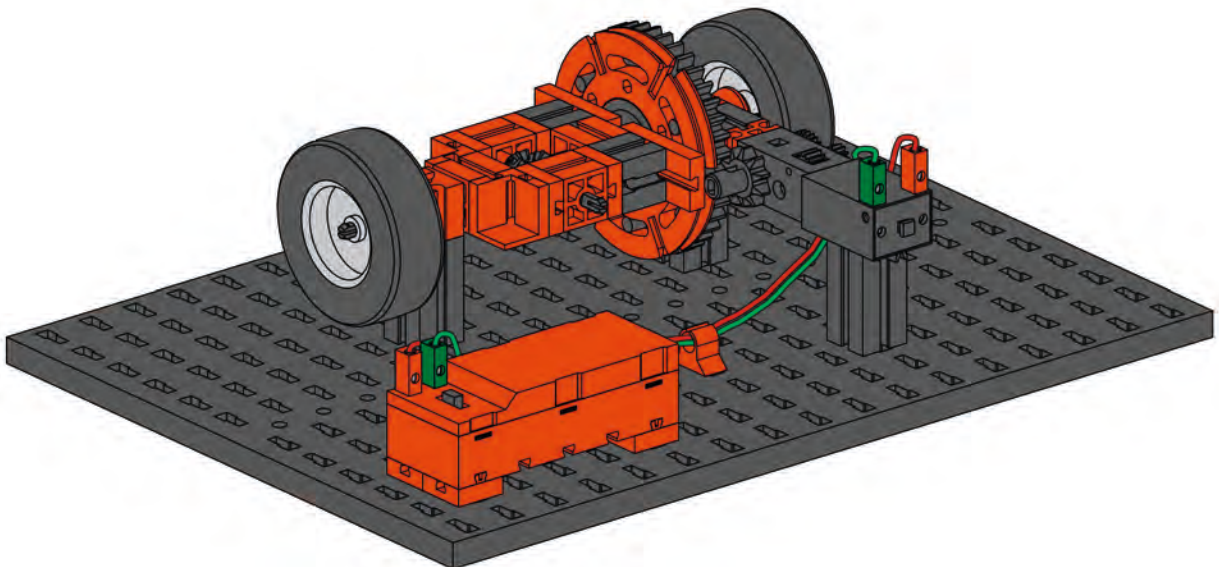
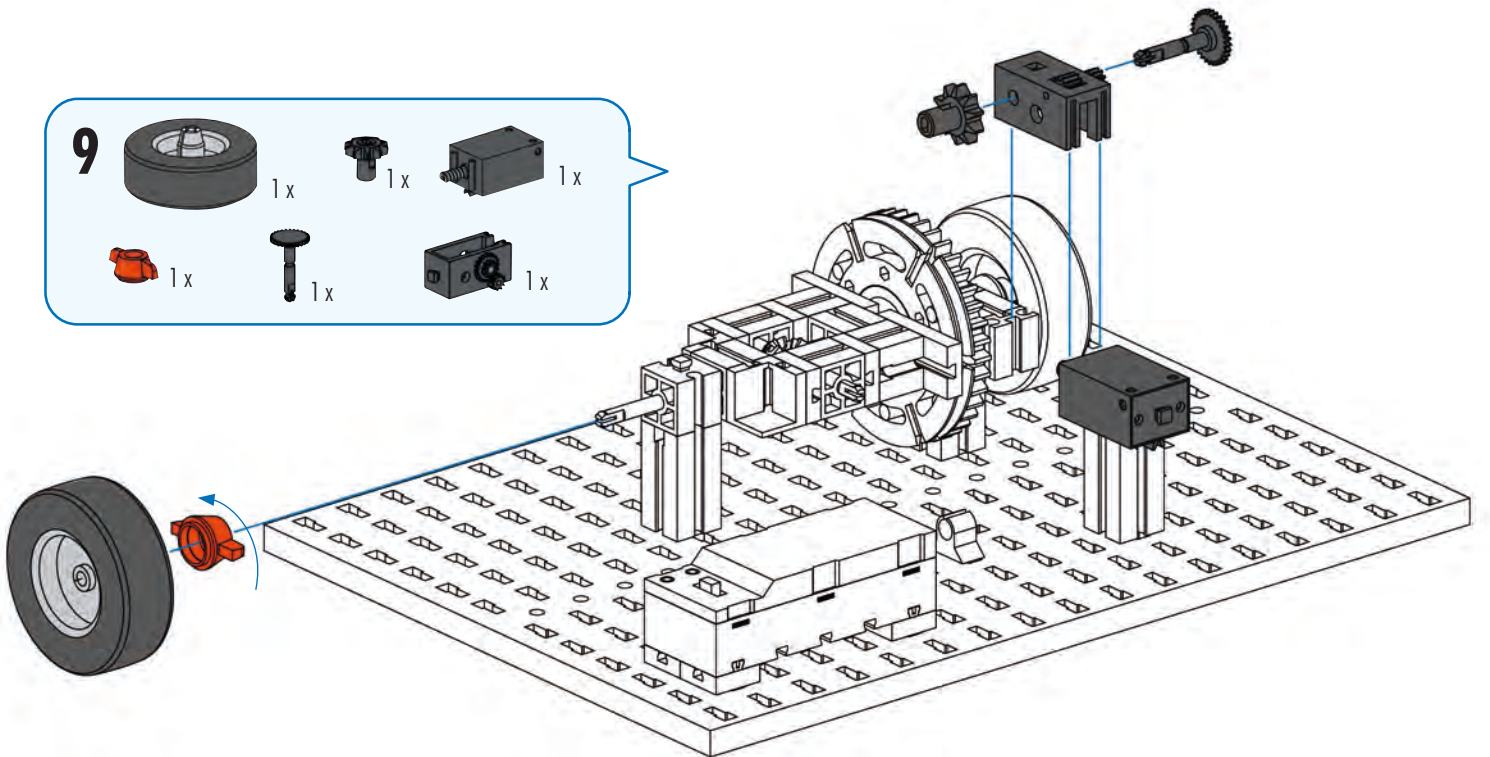



Scherenhubtisch mit Lenkung
 Scissor lift table with steering system
 Table élévatrice à ciseaux avec renvoi de direction

Schaarheftafel met stuur
 Mesa elevadora de tijera con dirección
 Mesa elevatória de tesouras com direção

Elevatore a pantografo con sterzo
 Ножничный подъёмный стол на тележке
 带转向机构的剪式升降台

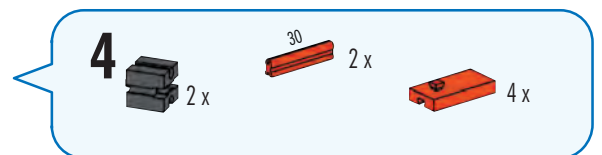
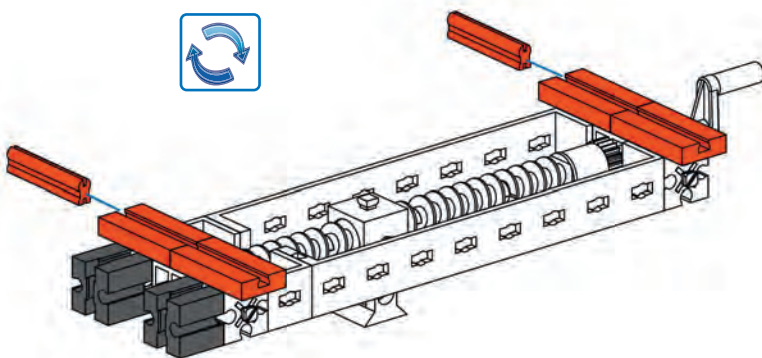
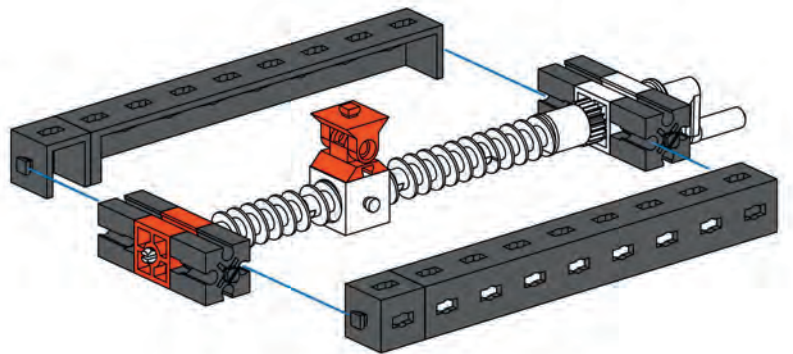
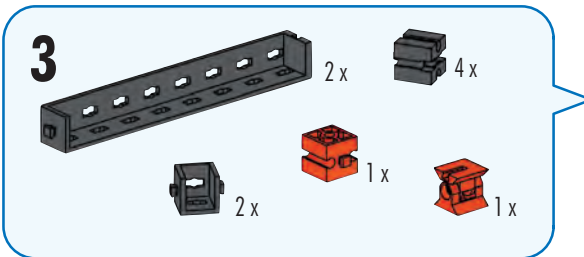
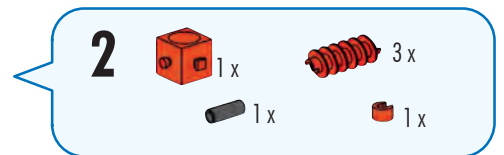
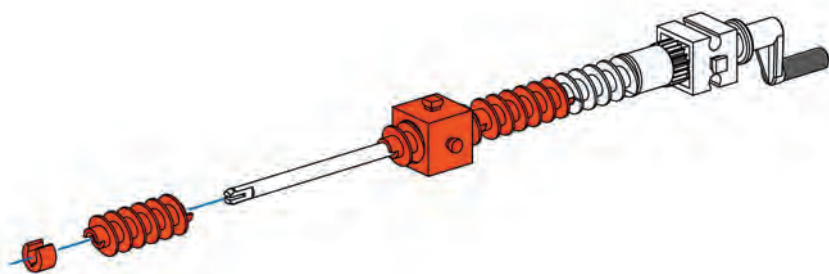
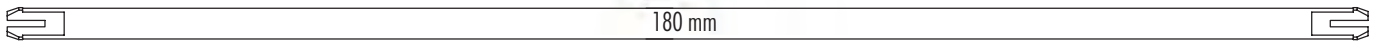
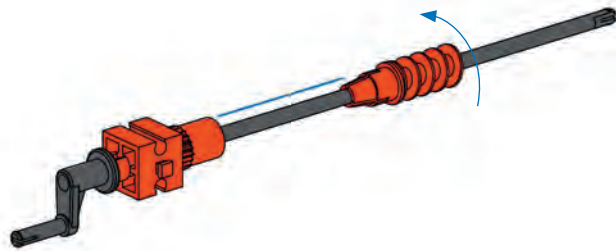
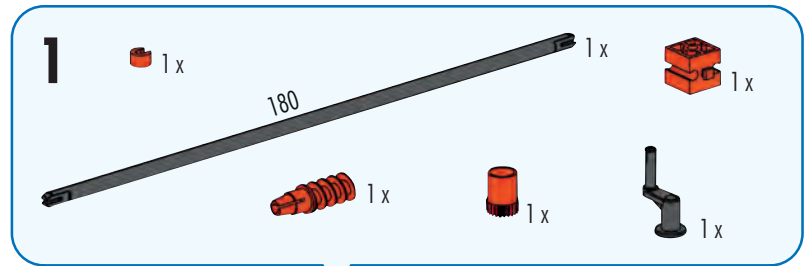

5

8x 2x 2x

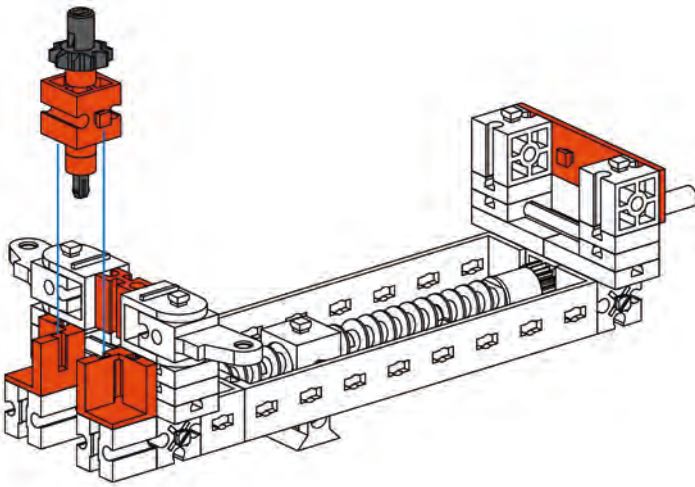
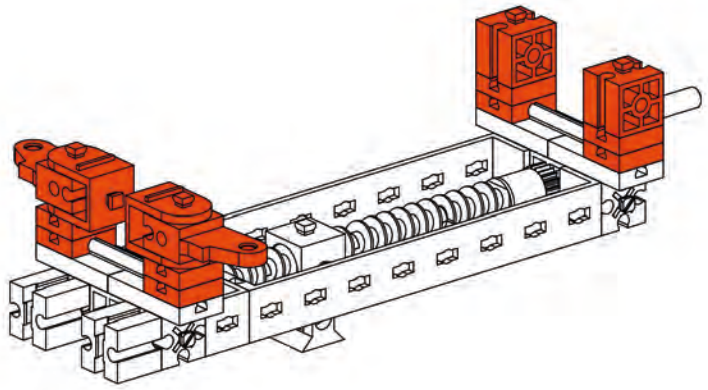

6

2x 1x 1x 1x 3x 1x

45 mm

7

30 1x 1x 15 1x 1x 1x

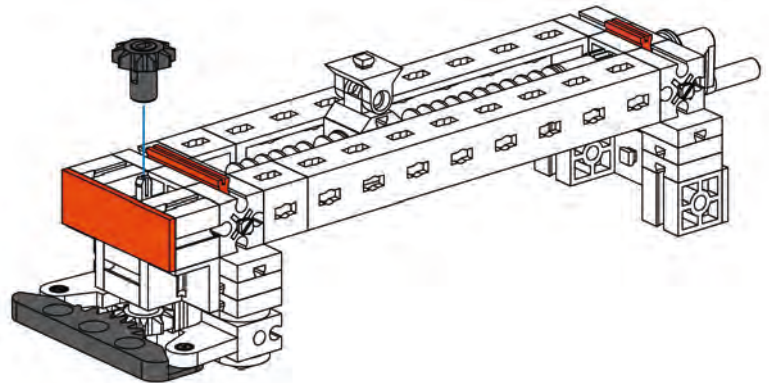

8

2x 2x 1x 1x

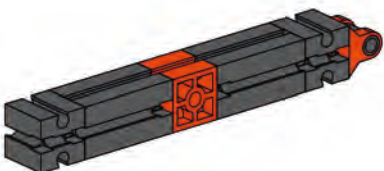

8

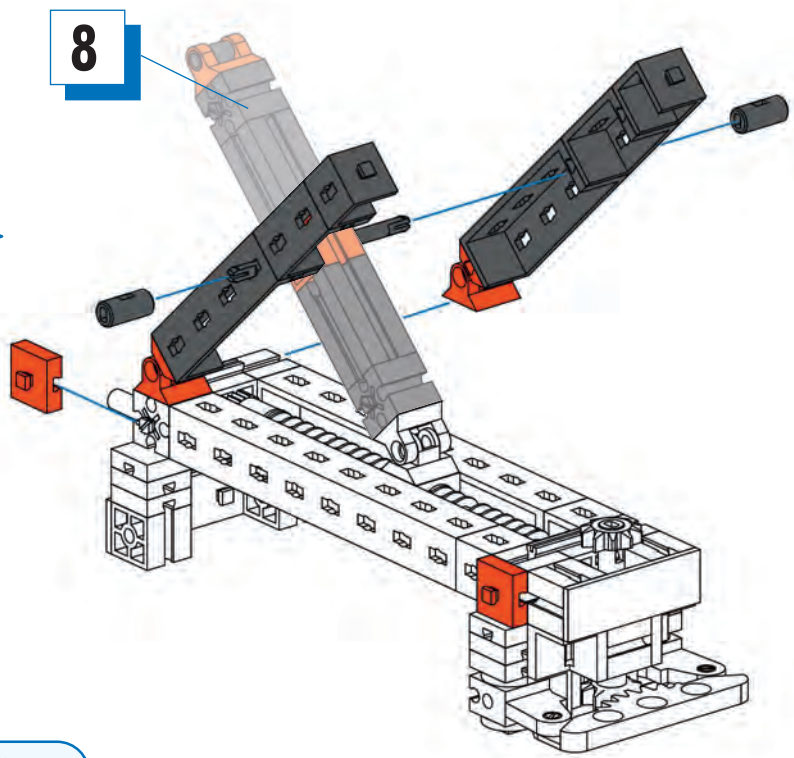

9

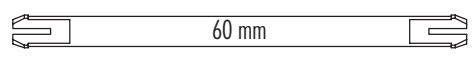
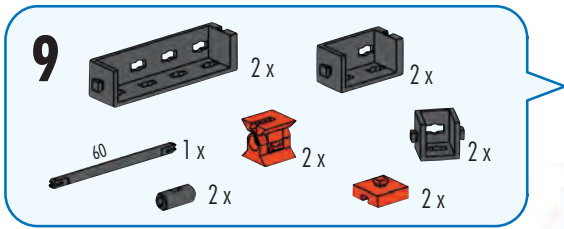

10

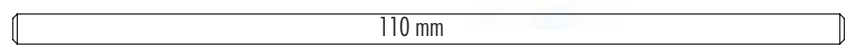
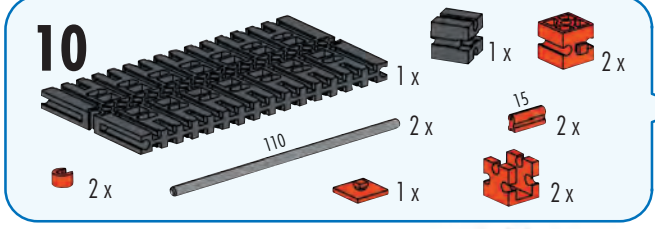

10

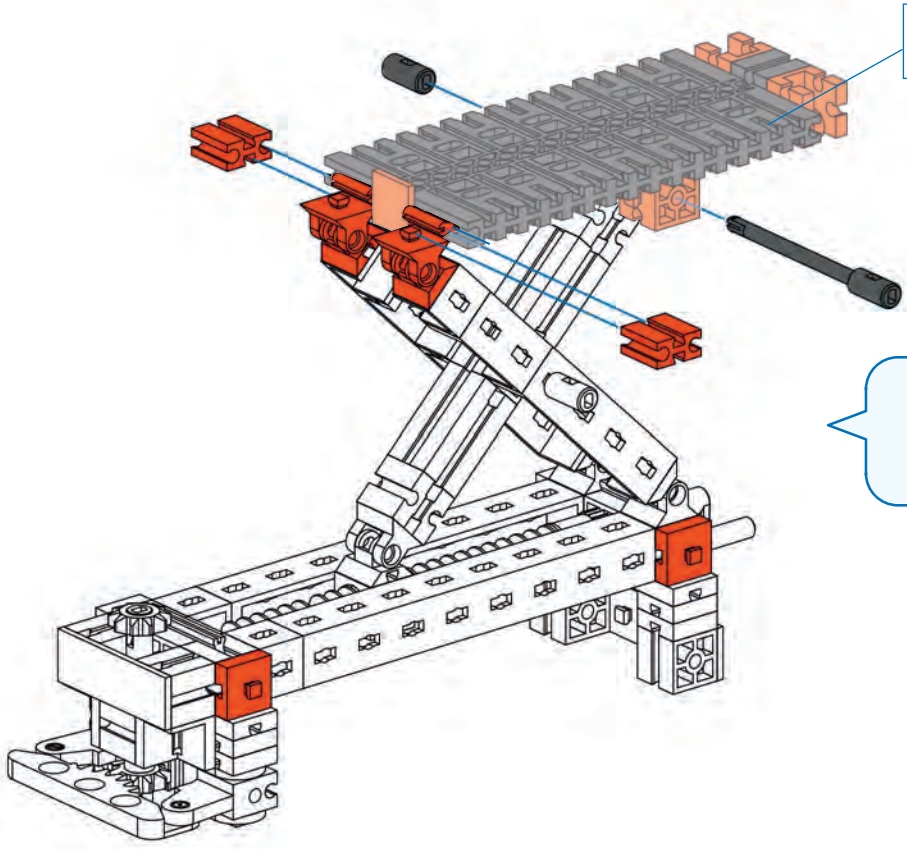

11

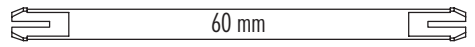
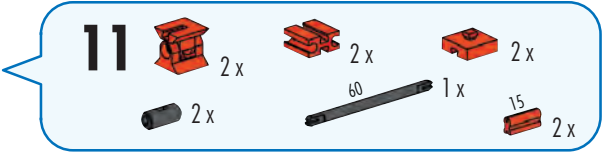

12

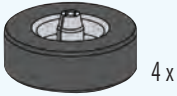

4 x



4 x



2 x



1 x



2 x



2 x



10 x



2 x



2 x

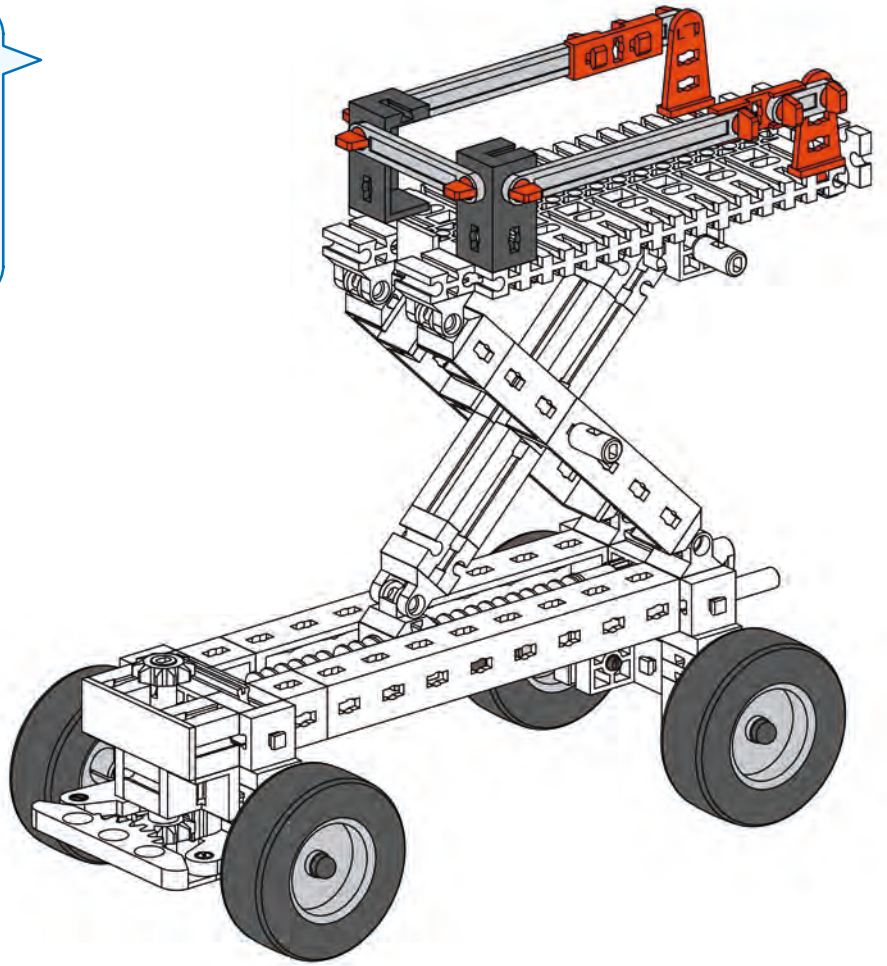

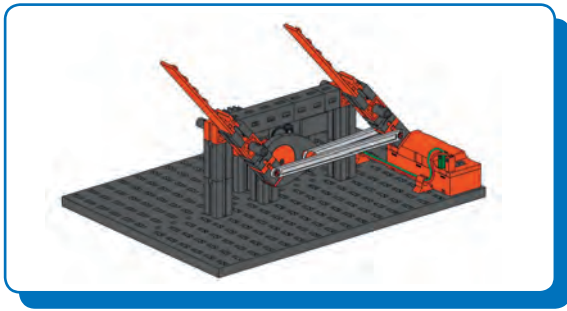

Scheibenwischer
Windshield wiper
Essuie-glace

Ruitenwischer
Limpiaparabrisas
Para-brisas

Tergicristallo
теклоочистители
刮雨器

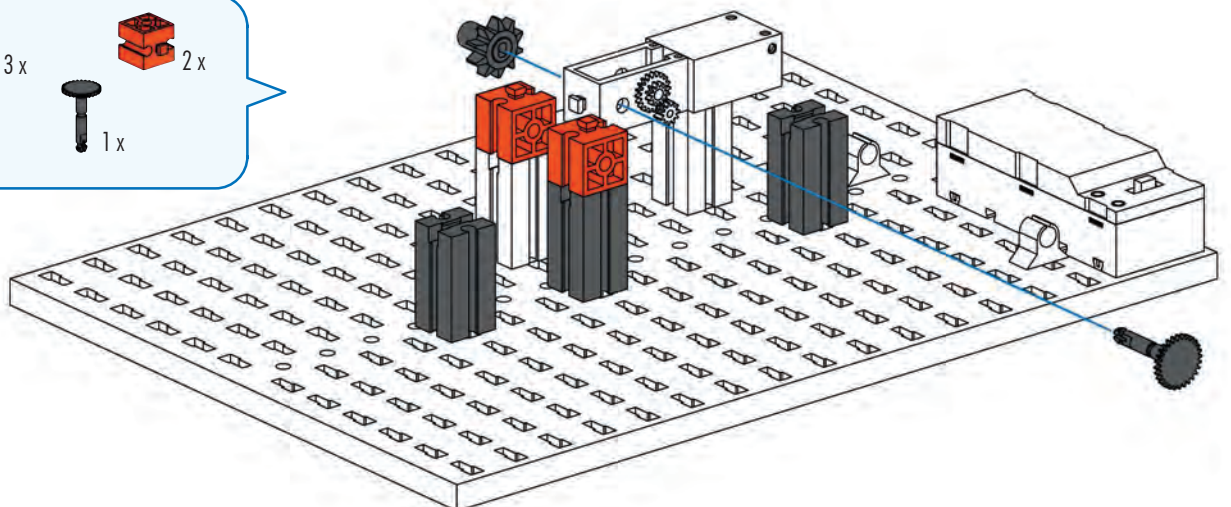
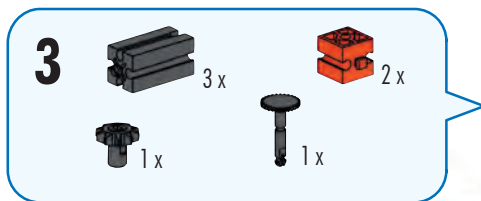
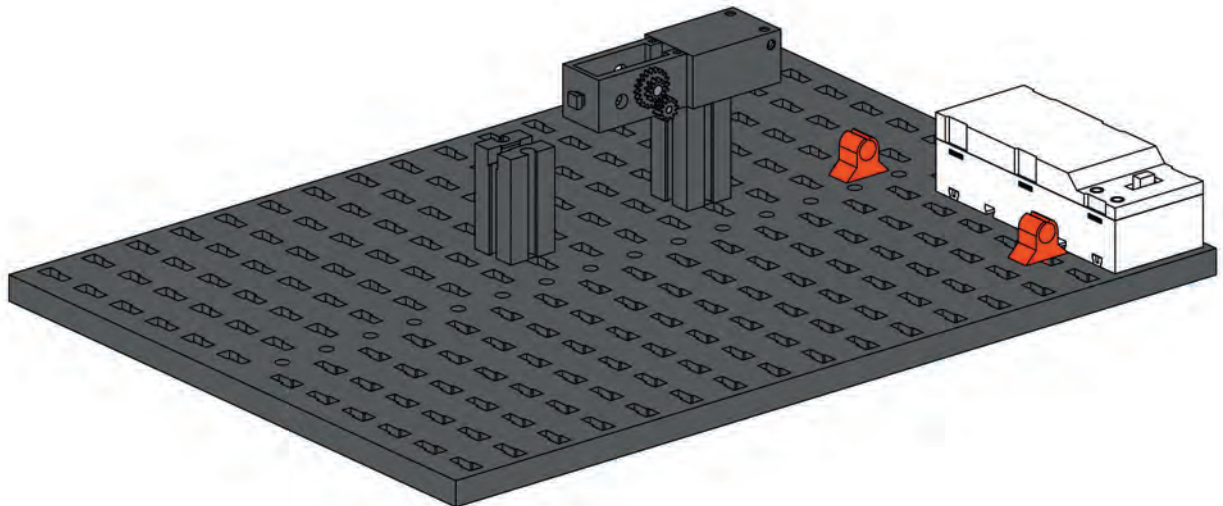
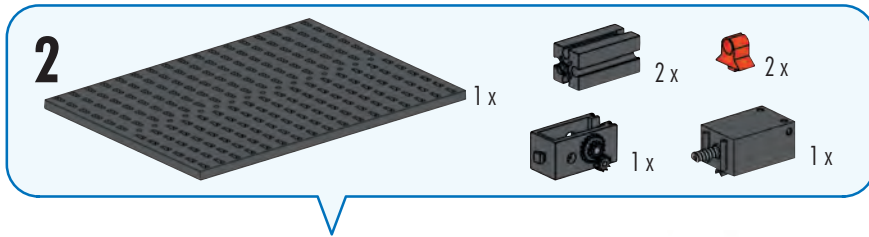
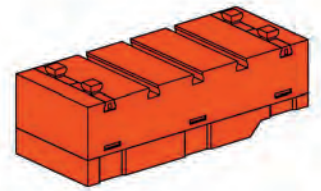
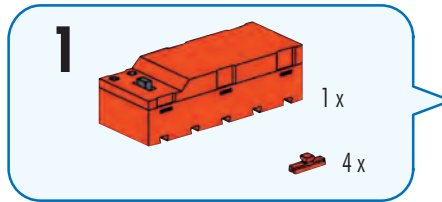



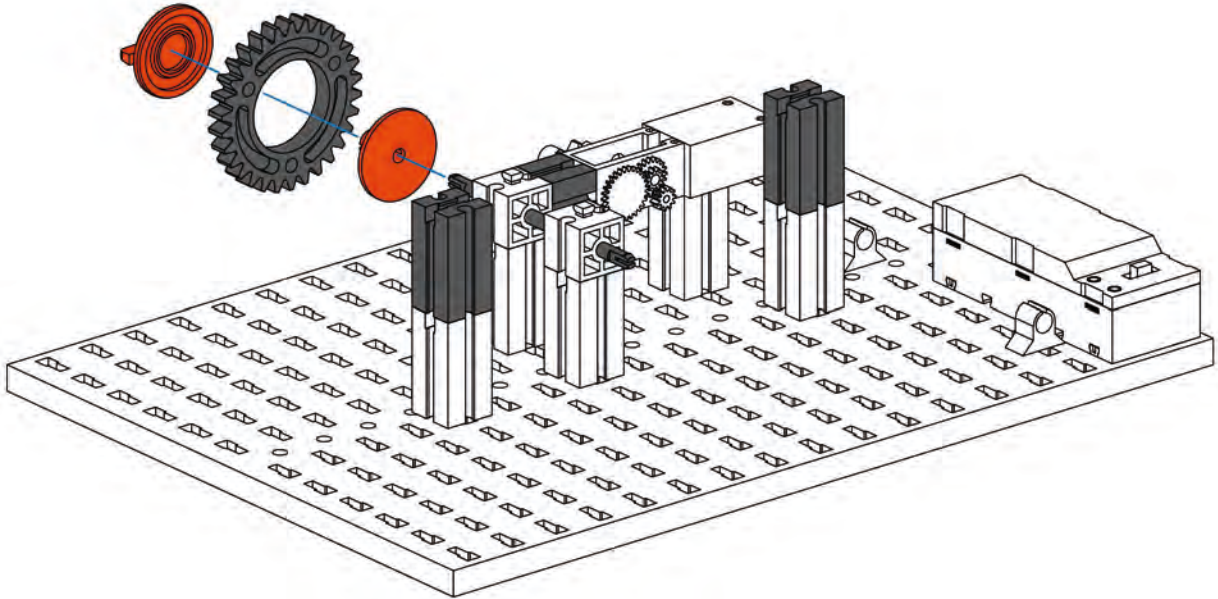
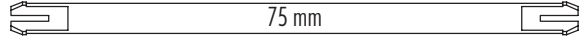
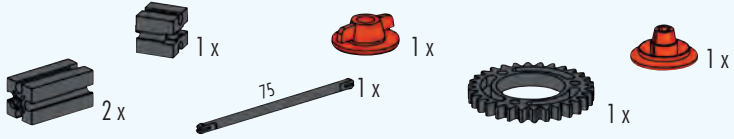

4

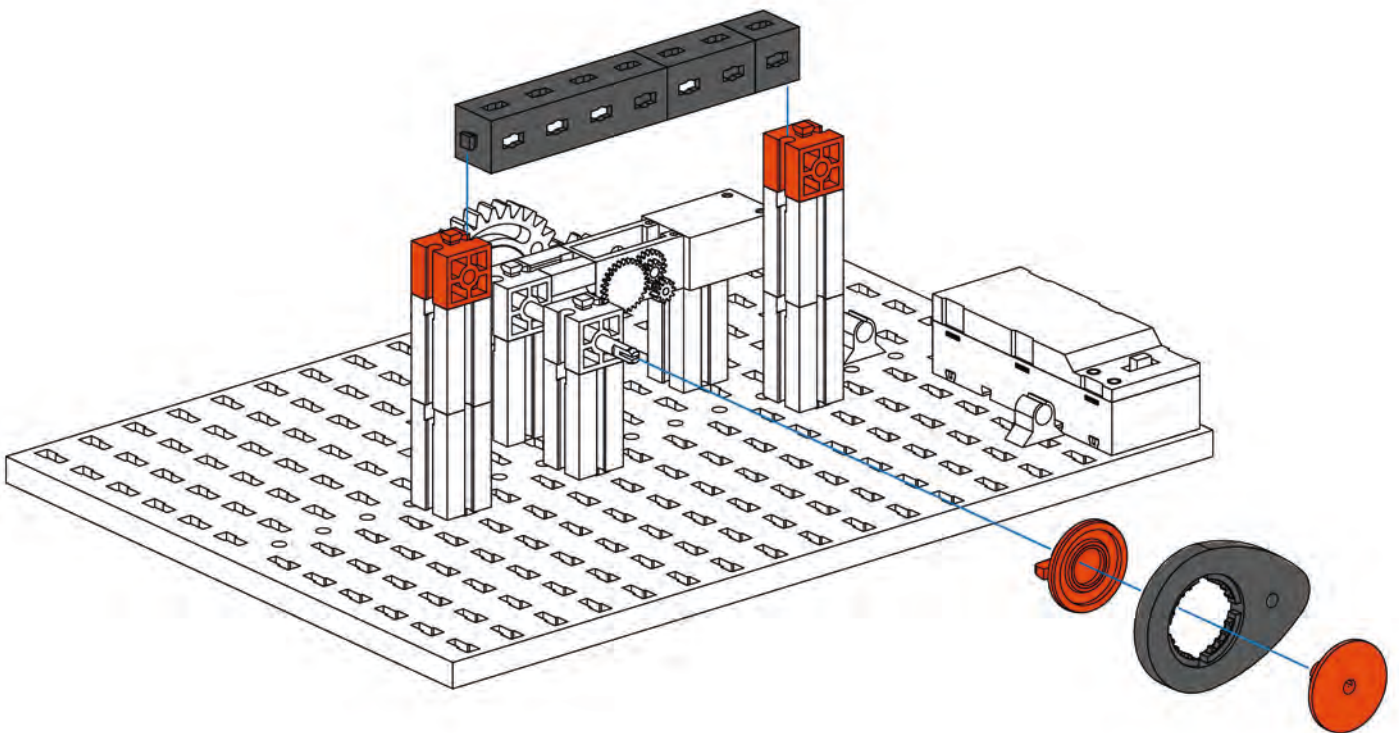
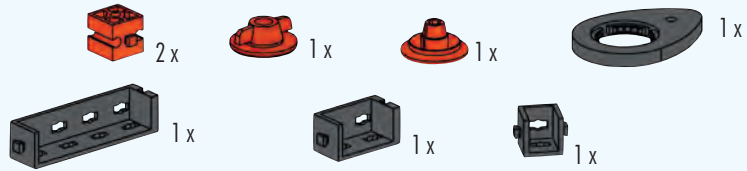

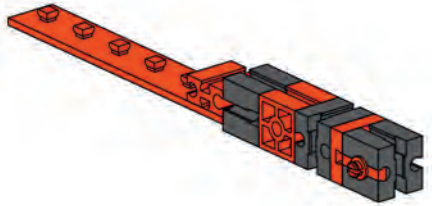
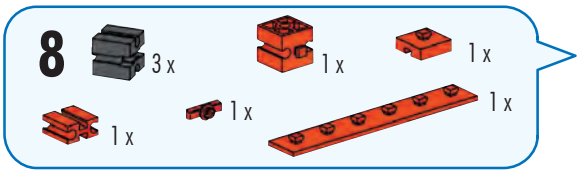
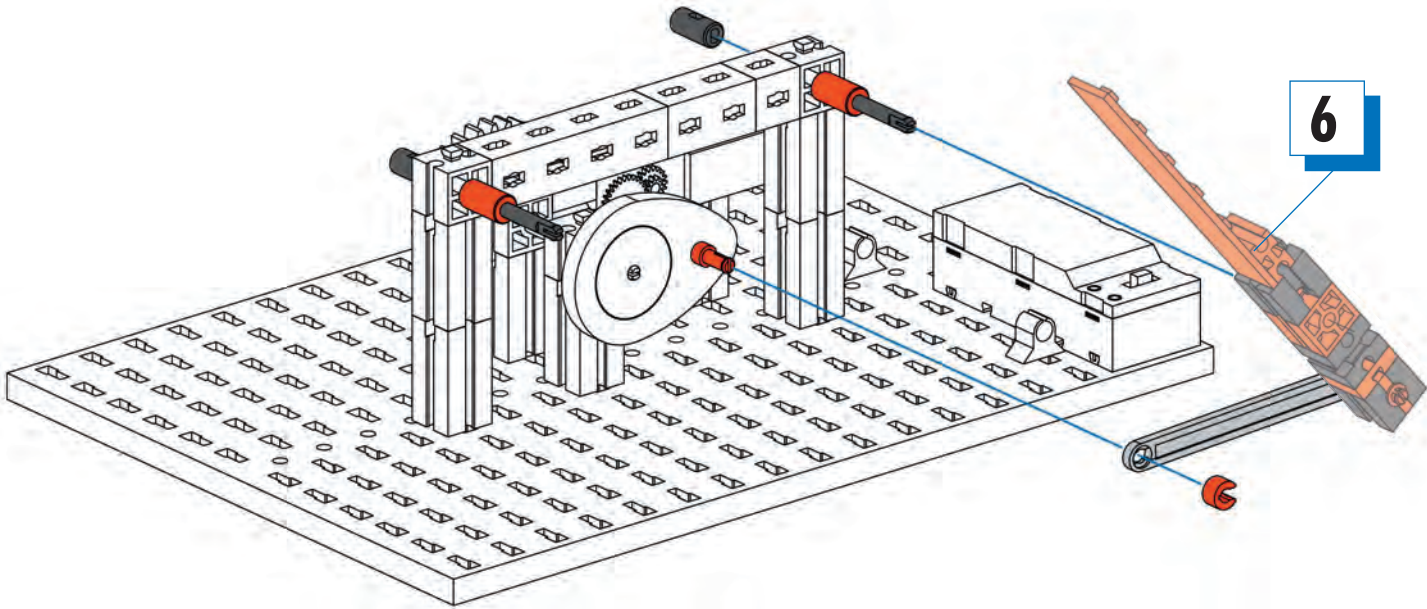
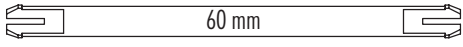
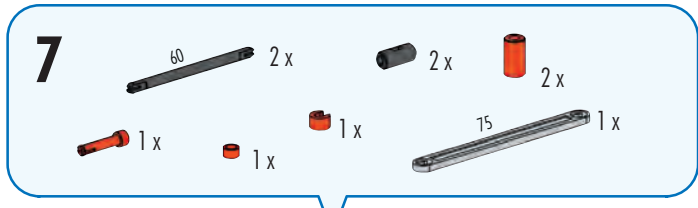
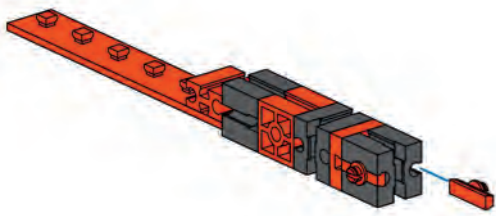
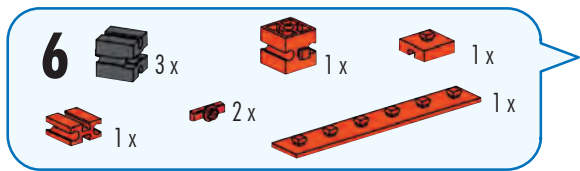
5



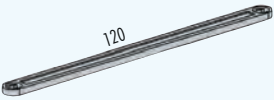

9  2 x  1 x  2 x

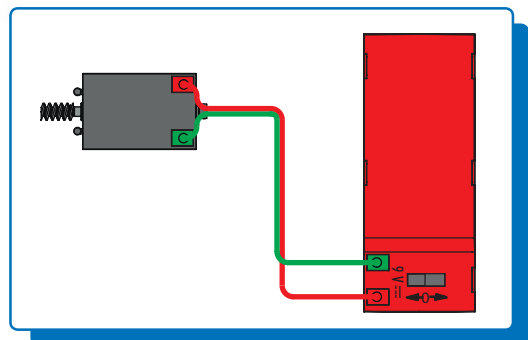
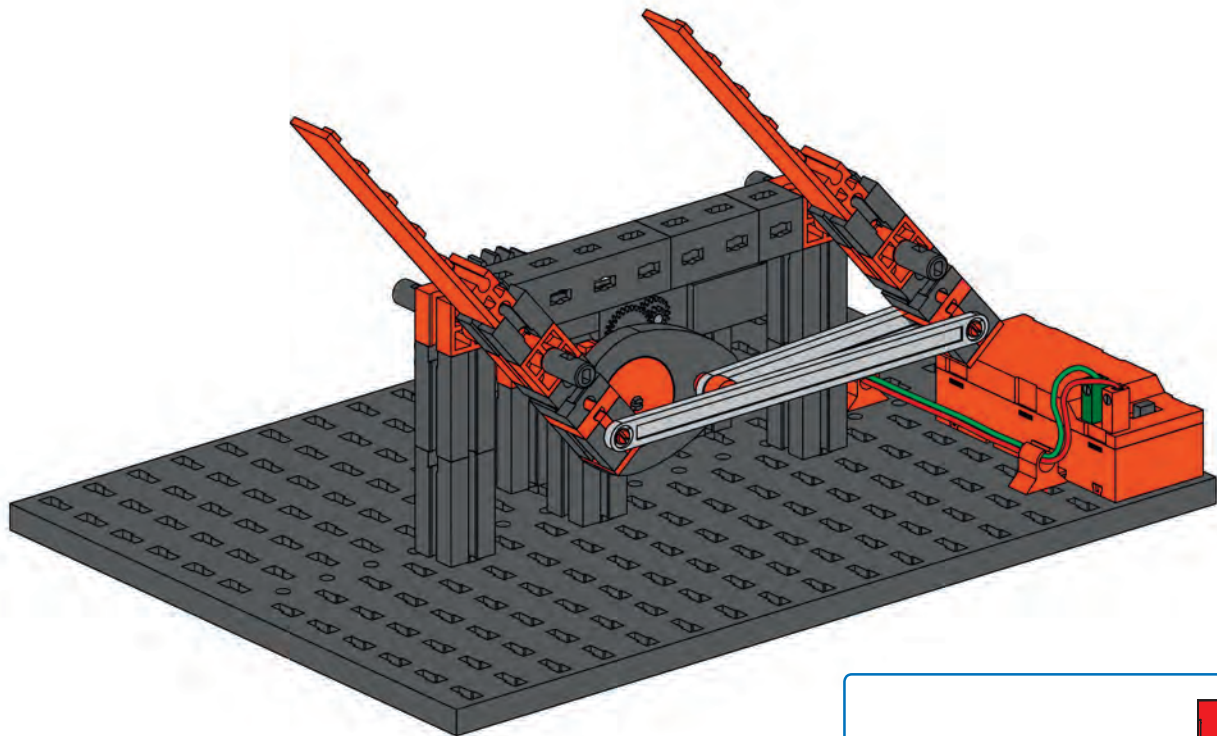
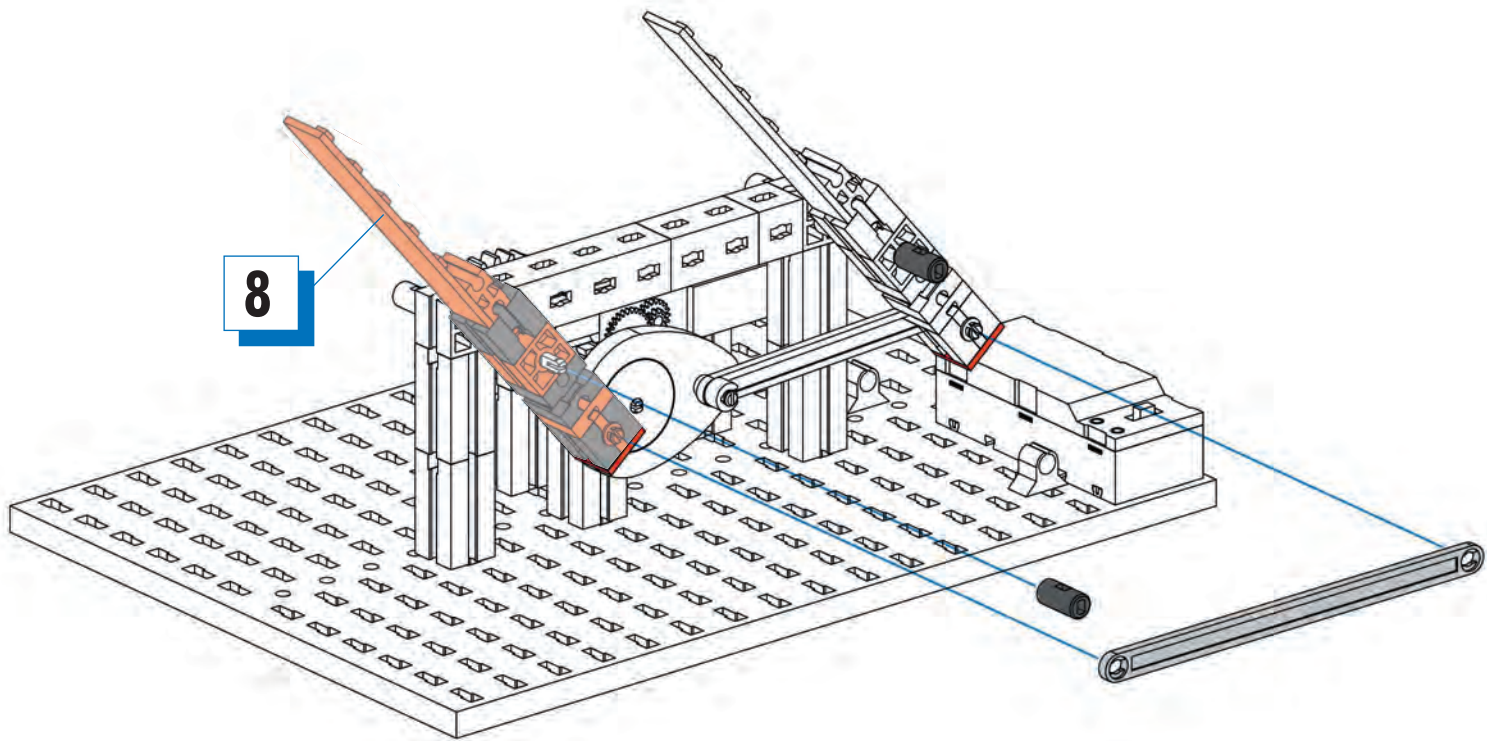



Viergelenkkette
Four-bar chain
Chaîne cinématique à quatre joints articulés

Vierscharniersmechanisme
Mecanismo de cuatro articulaciones
Corrente de quatro articulações

Catena a quattro articolazioni
Четырехзвенный шарнирный механизм
四活节链

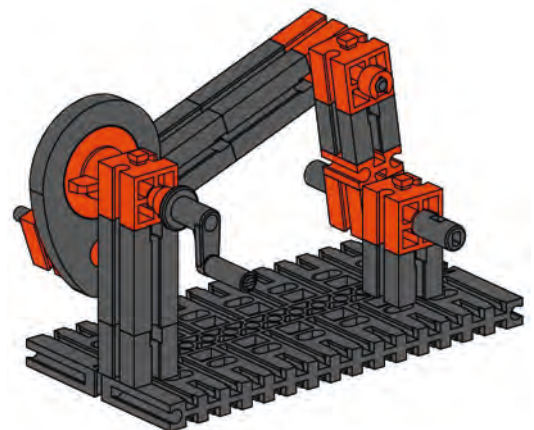
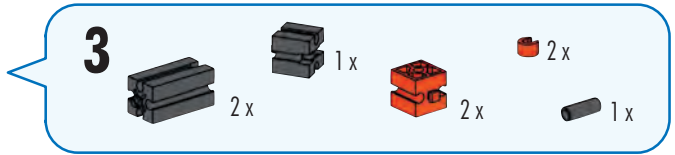
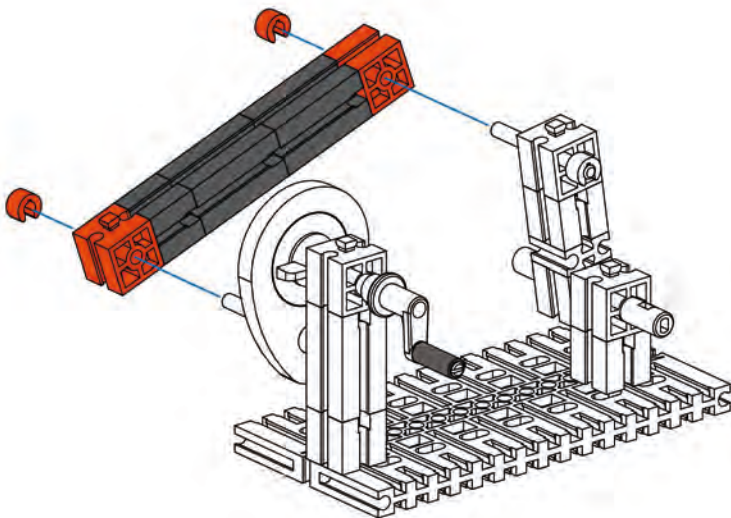
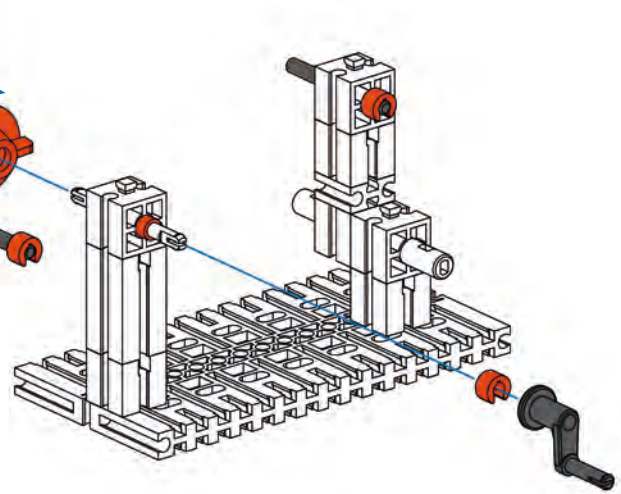
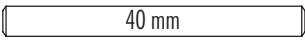
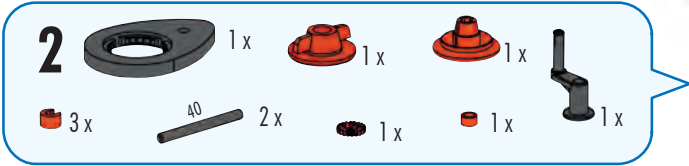
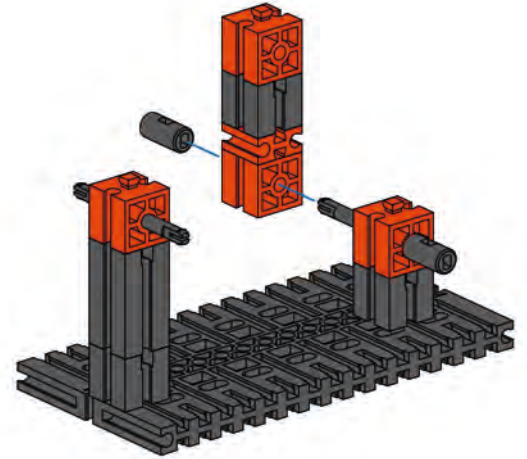
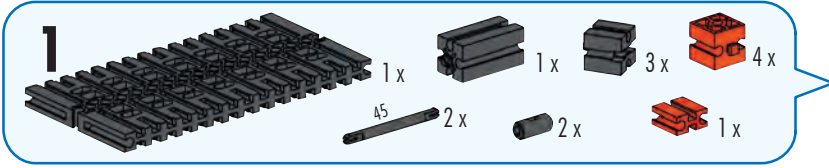

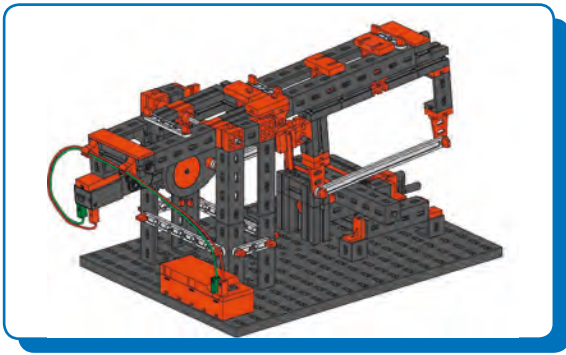



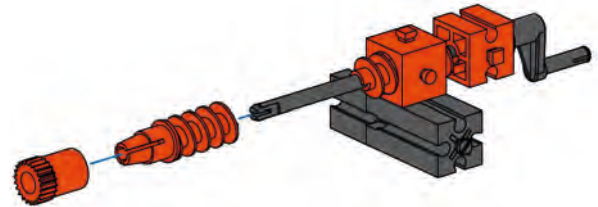
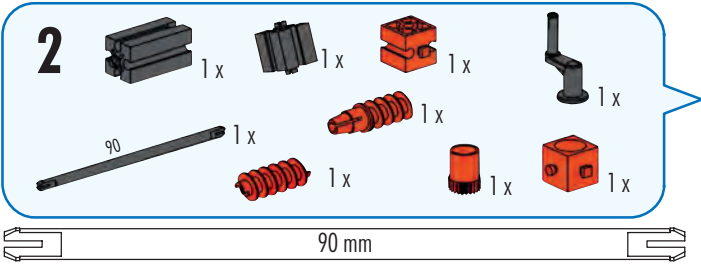
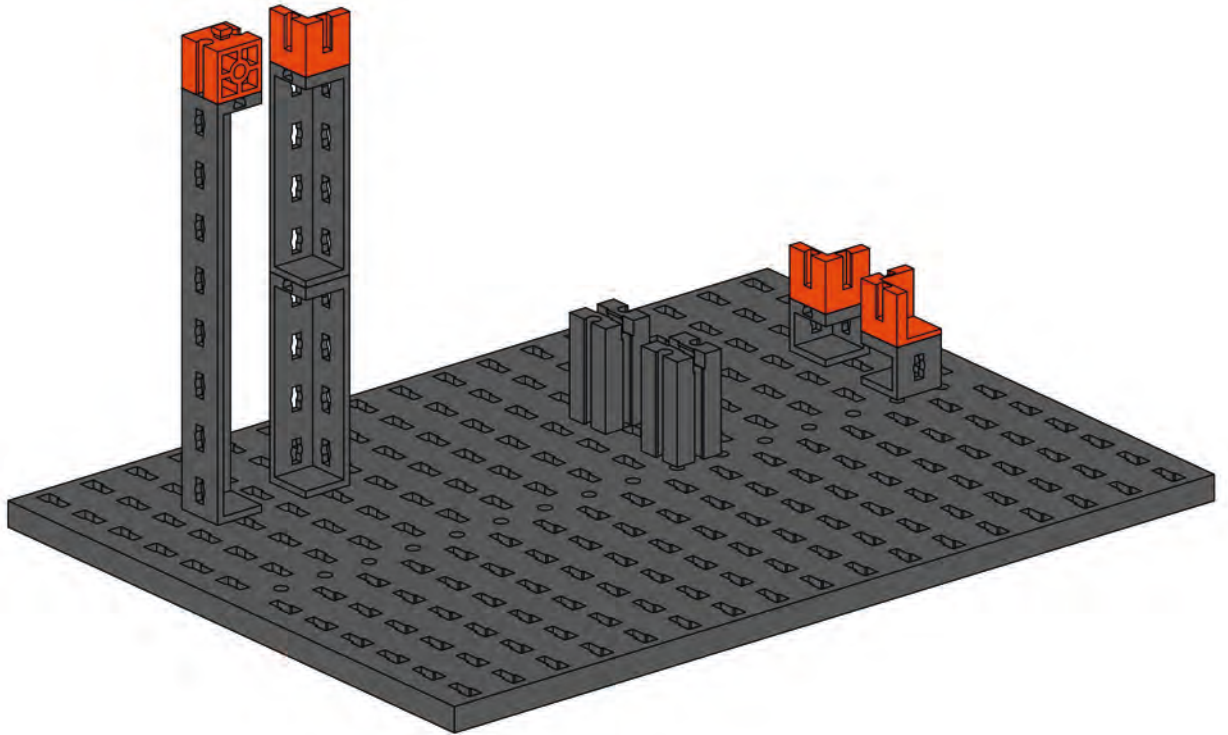
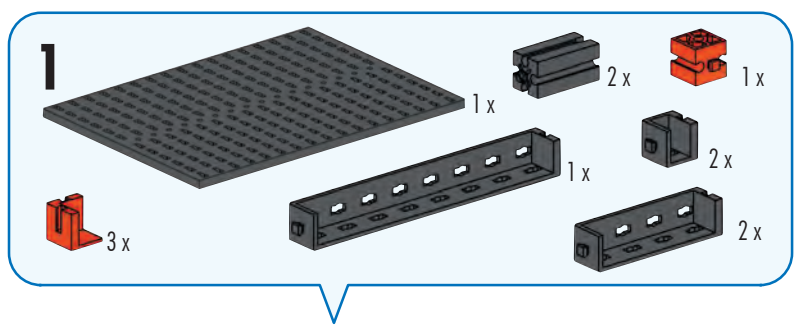

Bügelsäge
Power hacksaw machine
Scie à archet

Beugelzaag
Sierra de arco
Serra de arco

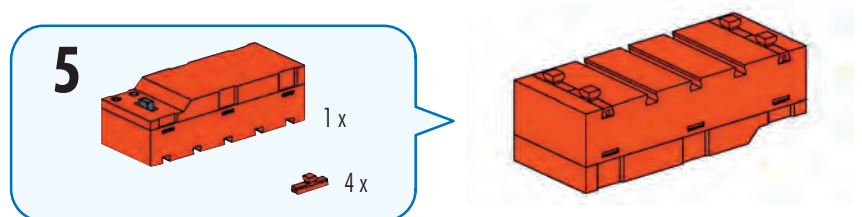
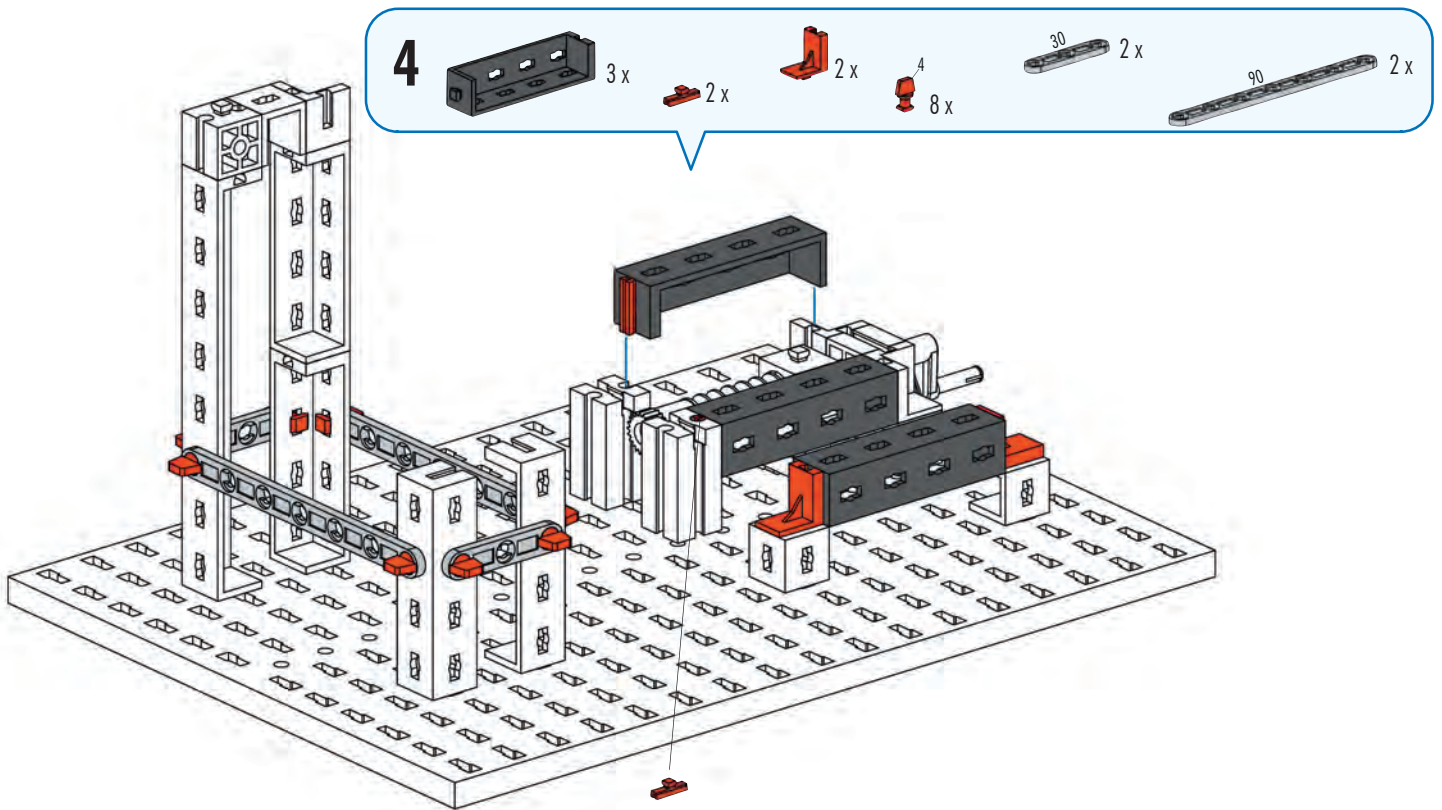
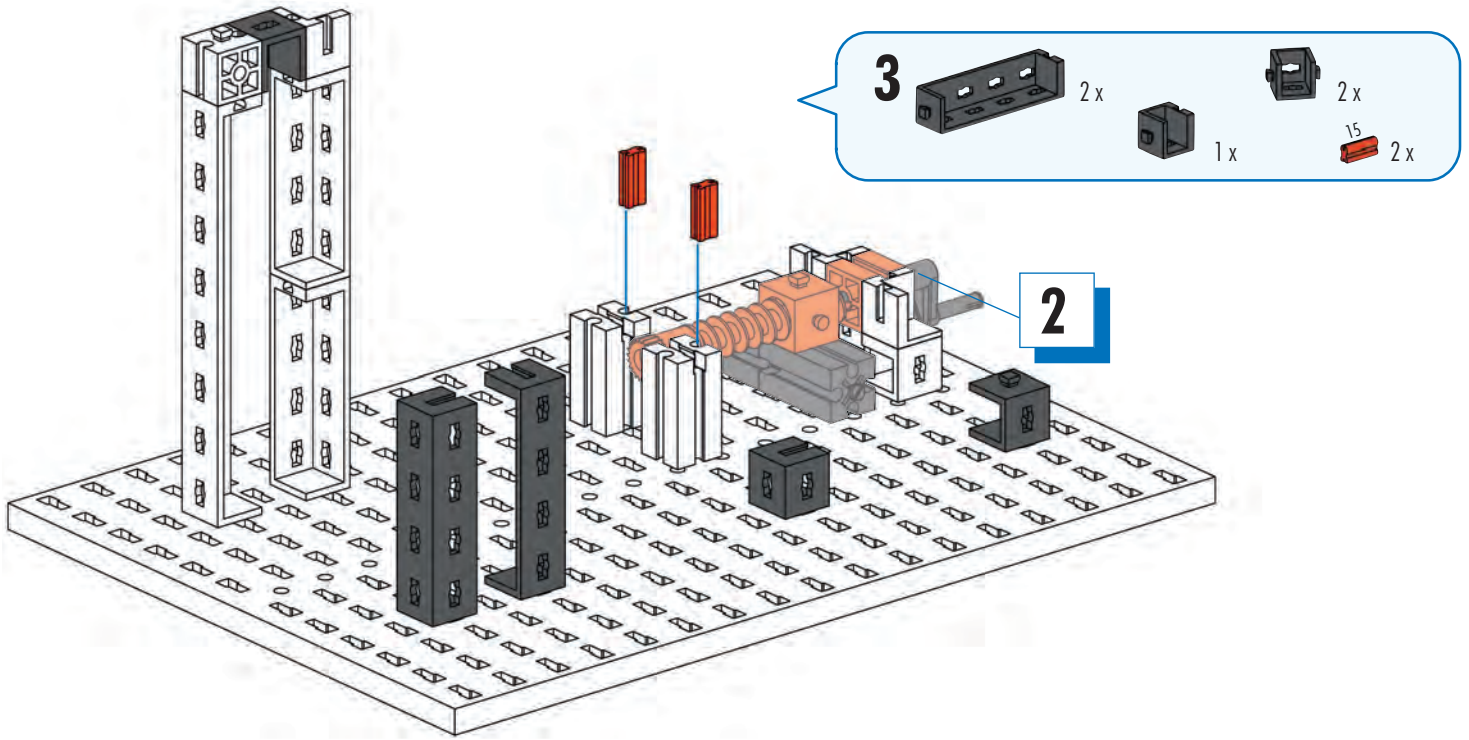
Seghetto ad arco
Ножовка
弓锯







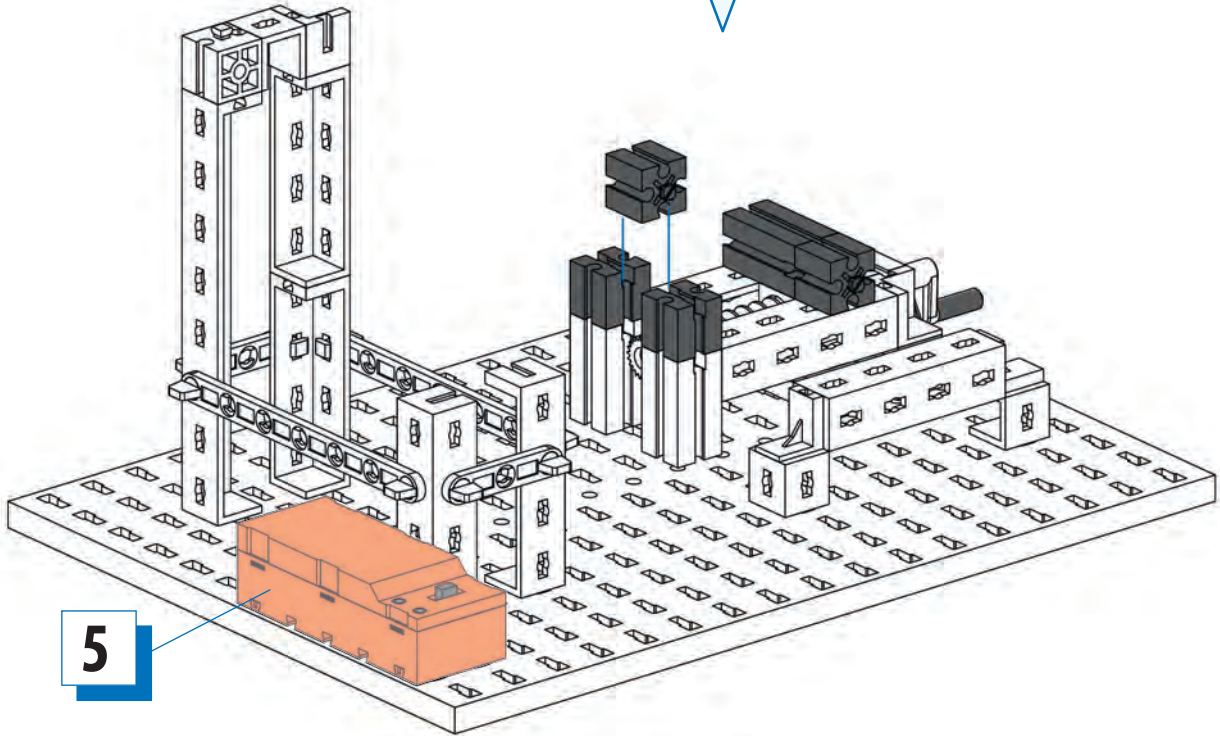





- 6**  1x  2x  2x  1x









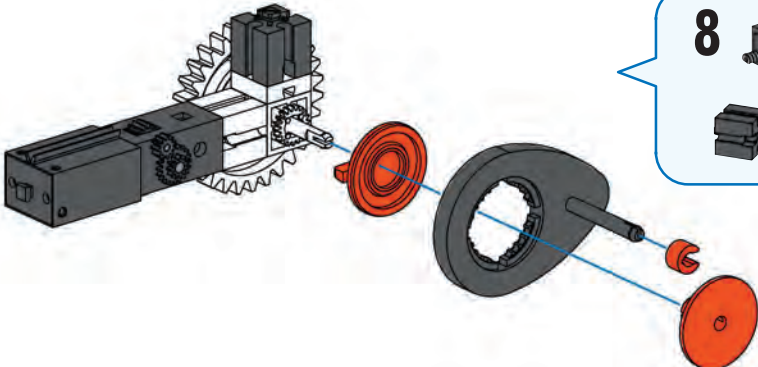
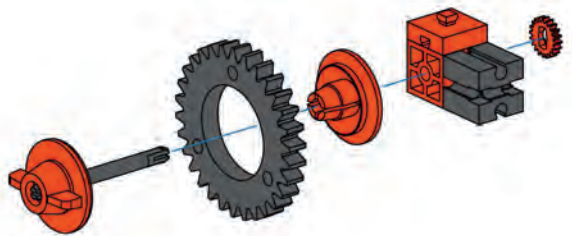

5

- 7**  1x  1x  1x  1x
 45 1x  1x  1x  1x

45 mm



- 8**  1x  1x  1x  1x
 1x  1x  1x  1x

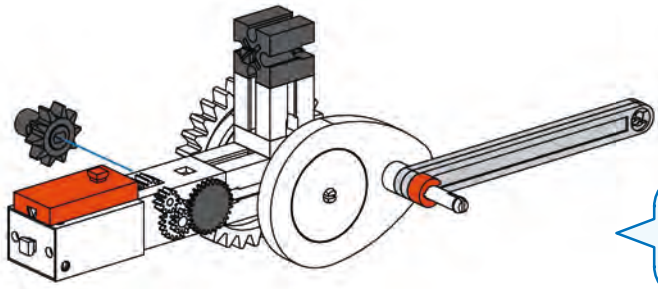

9

- 1x [Black 1x2 Technic Brick]
- 1x [Red 1x2 Technic Brick]
- 1x [Black Technic Pin]
- 1x [Black Technic Pin]
- 1x [Red Technic Pin]
- 2x [Black Technic Axle, length 75]

10

- 2x [Black 1x2 Technic Brick]
- 1x [Black 1x2 Technic Brick]
- 1x [Black 1x2 Technic Brick]
- 2x [Red 1x2 Technic Brick]
- 1x [Black 1x2 Technic Brick]
- 2x [Black 1x2 Technic Brick]
- 1x [Black 1x2 Technic Brick]

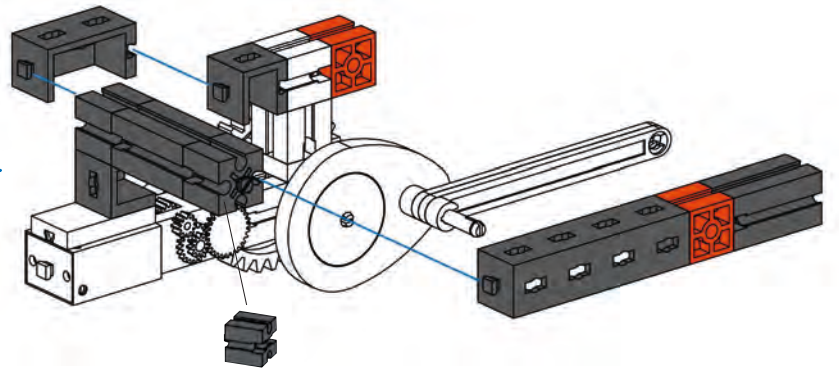

11

- 5x [Black 1x2 Technic Brick]
- 1x [Black 1x2 Technic Brick]
- 2x [Red 1x2 Technic Brick]
- 6x [Red 1x2 Technic Brick]
- 1x [Red 1x2 Technic Brick]
- 2x [Red 1x2 Technic Brick]
- 1x [Red 1x2 Technic Brick]
- 2x [Red Technic Pin]

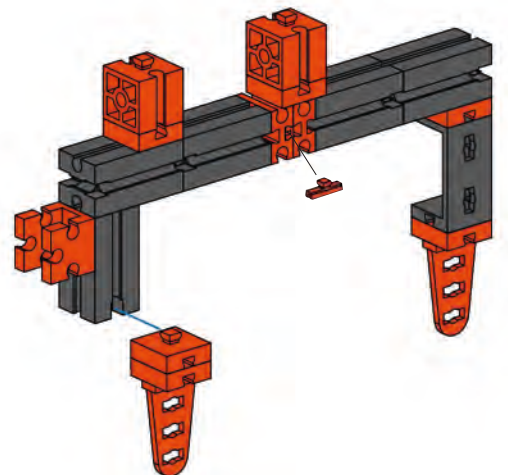

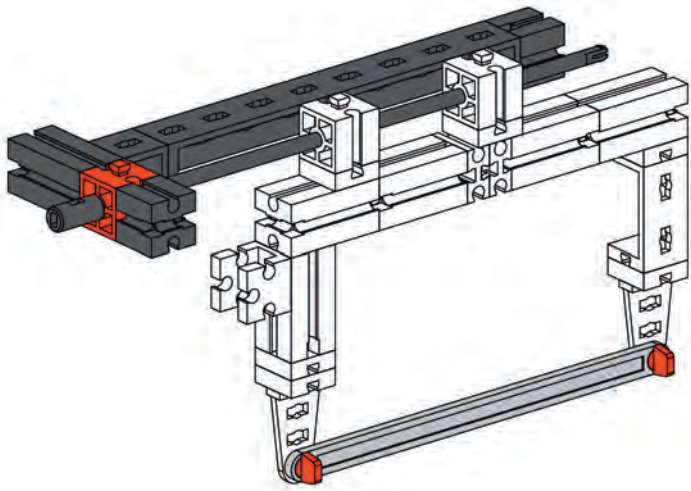

12

- 1 x 120 Technic Beam
- 1 x 180 Technic Beam
- 1 x 2x1 Technic Connector
- 2 x 1x1 Technic Connector
- 1 x 1x2 Technic Connector
- 1 x 1x3 Technic Connector
- 1 x 1x4 Technic Connector
- 1 x 1x6 Technic Connector
- 1 x Pin
- 1 x Red 1x1 Technic Connector
- 2 x Red 4-way Technic Connector

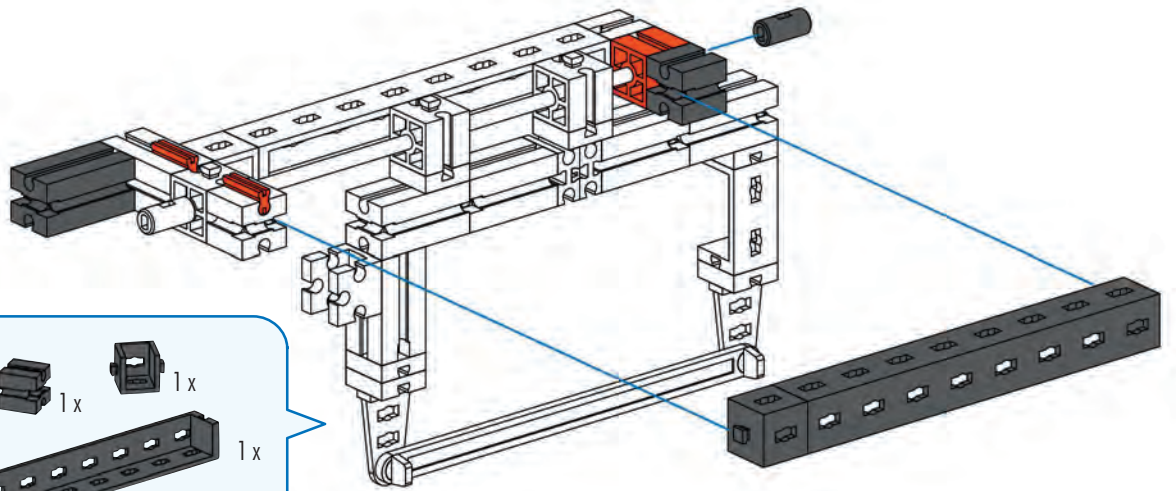

13

- 1 x 2x1 Technic Connector
- 1 x 1x1 Technic Connector
- 1 x 1x2 Technic Connector
- 1 x Pin
- 1 x Red 1x1 Technic Connector
- 1 x 120 Technic Beam
- 2 x Red 4-way Technic Connector

14

- 2 x 30 Technic Beam
- 4 x Red 4-way Technic Connector
- 1 x Red 1x4 Technic Connector
- 2 x Red 1x1 Technic Connector
- 1 x 40 Technic Beam

40 mm

10

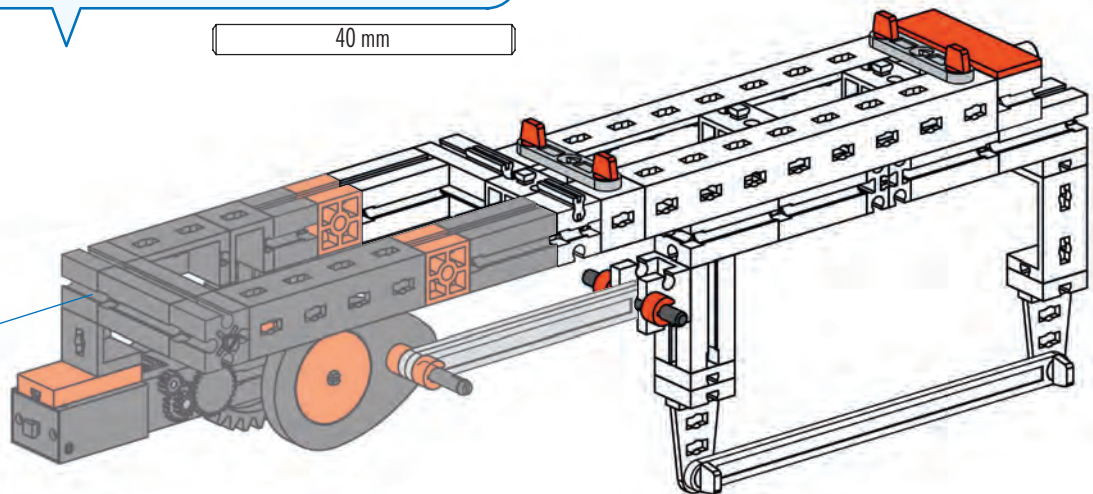

15

- 110 1x
- 1x
- 2x
- 2x

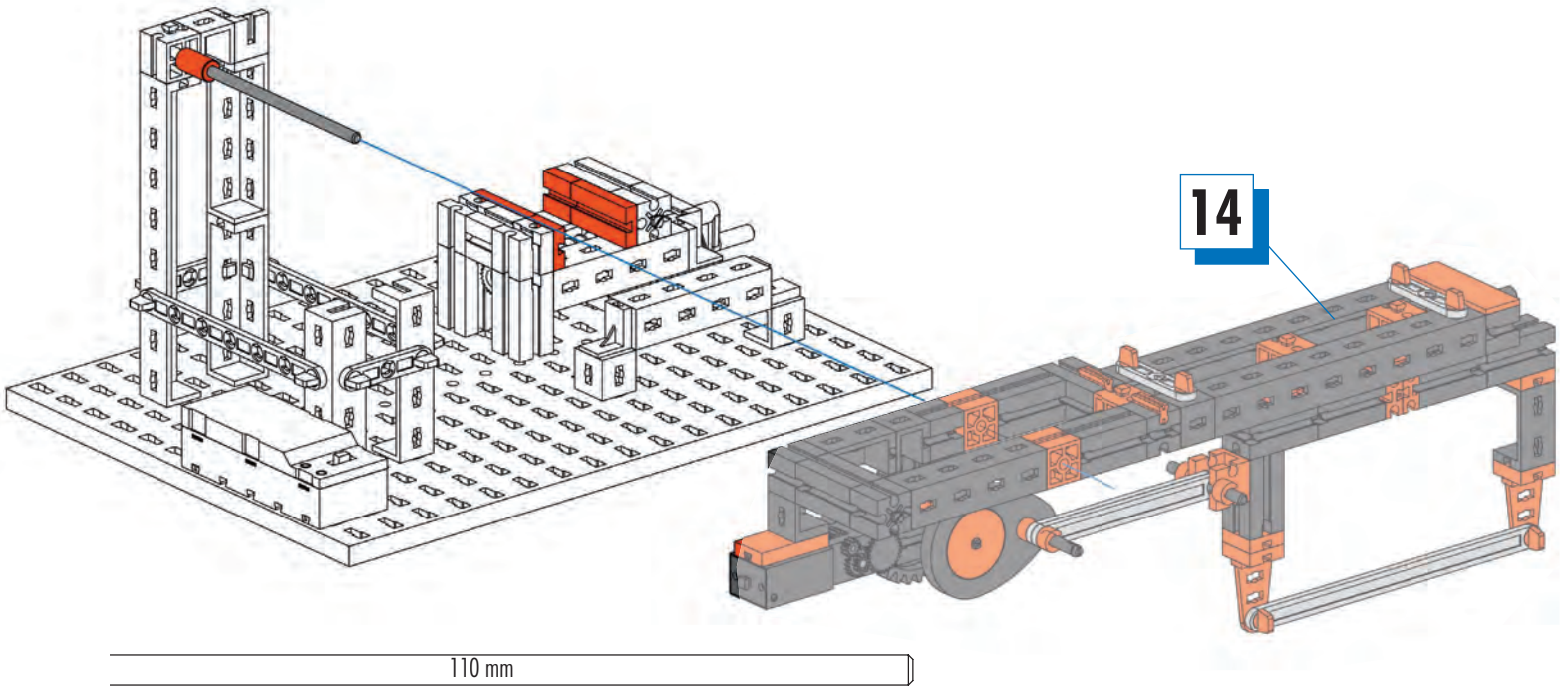

16

- 2x
- 1x
- 2x
- 3x
- 2x
- 2x
- 1x

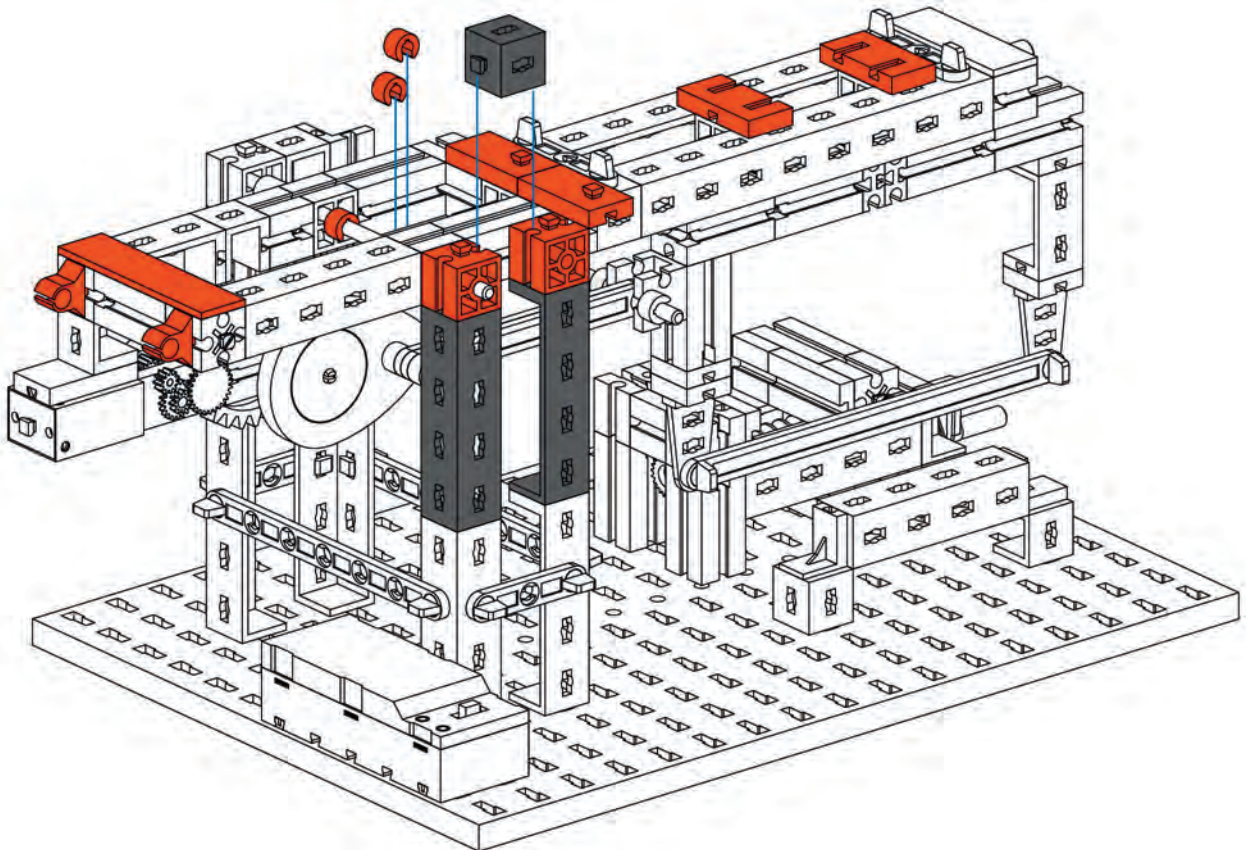

17

- 1 x [Red 1x2 Technic Brick]
- 1 x [Red 1x3 Technic Brick]
- 2 x [Red Pin]
- 1 x [Red 30 Technic Beam]
- 1 x [Grey 45 Technic Beam]
- 1 x [Black 1x2 Technic Brick]
- 1 x [Red 1x2 Technic Brick]
- 1 x [Red 1x3 Technic Brick]

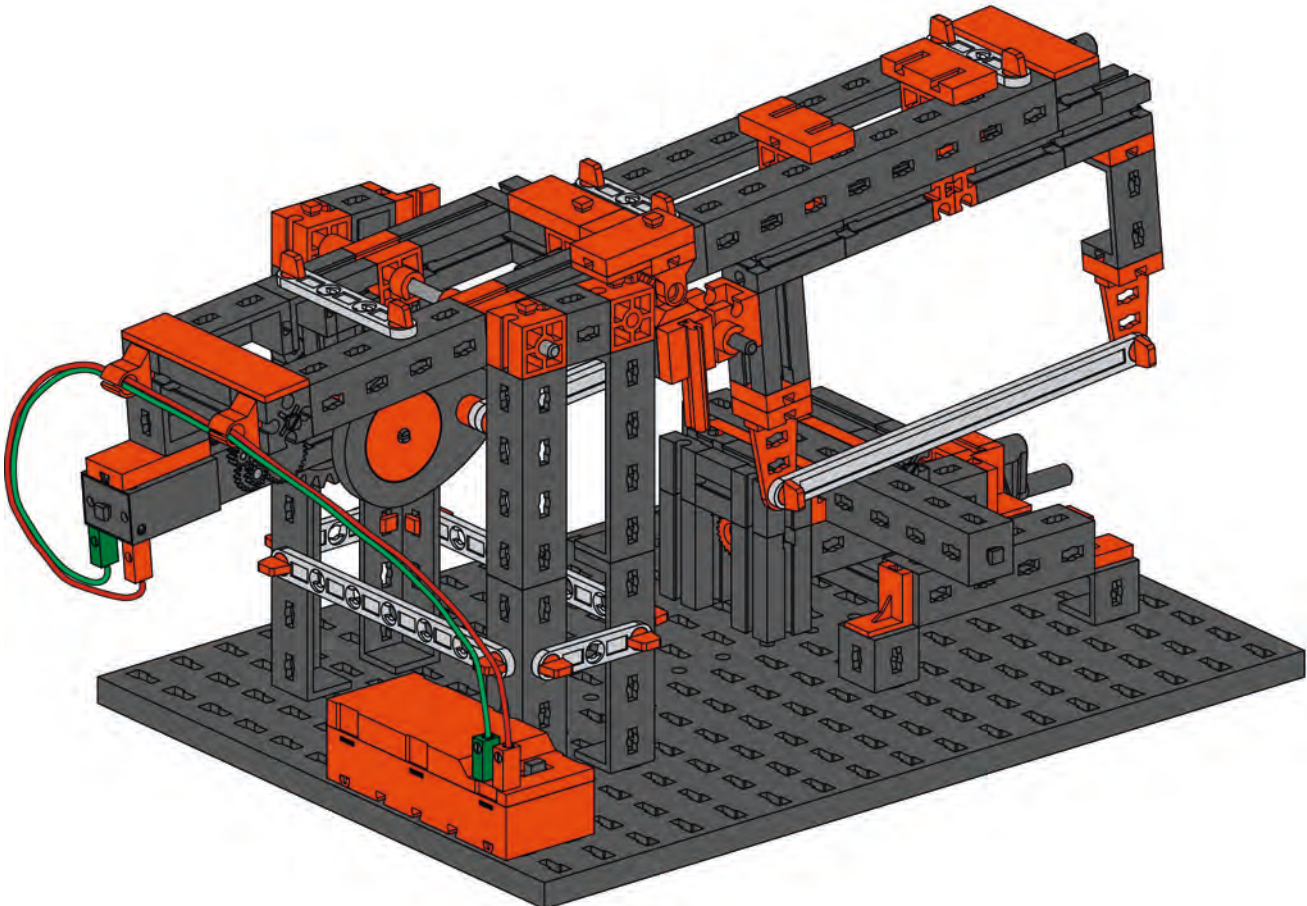
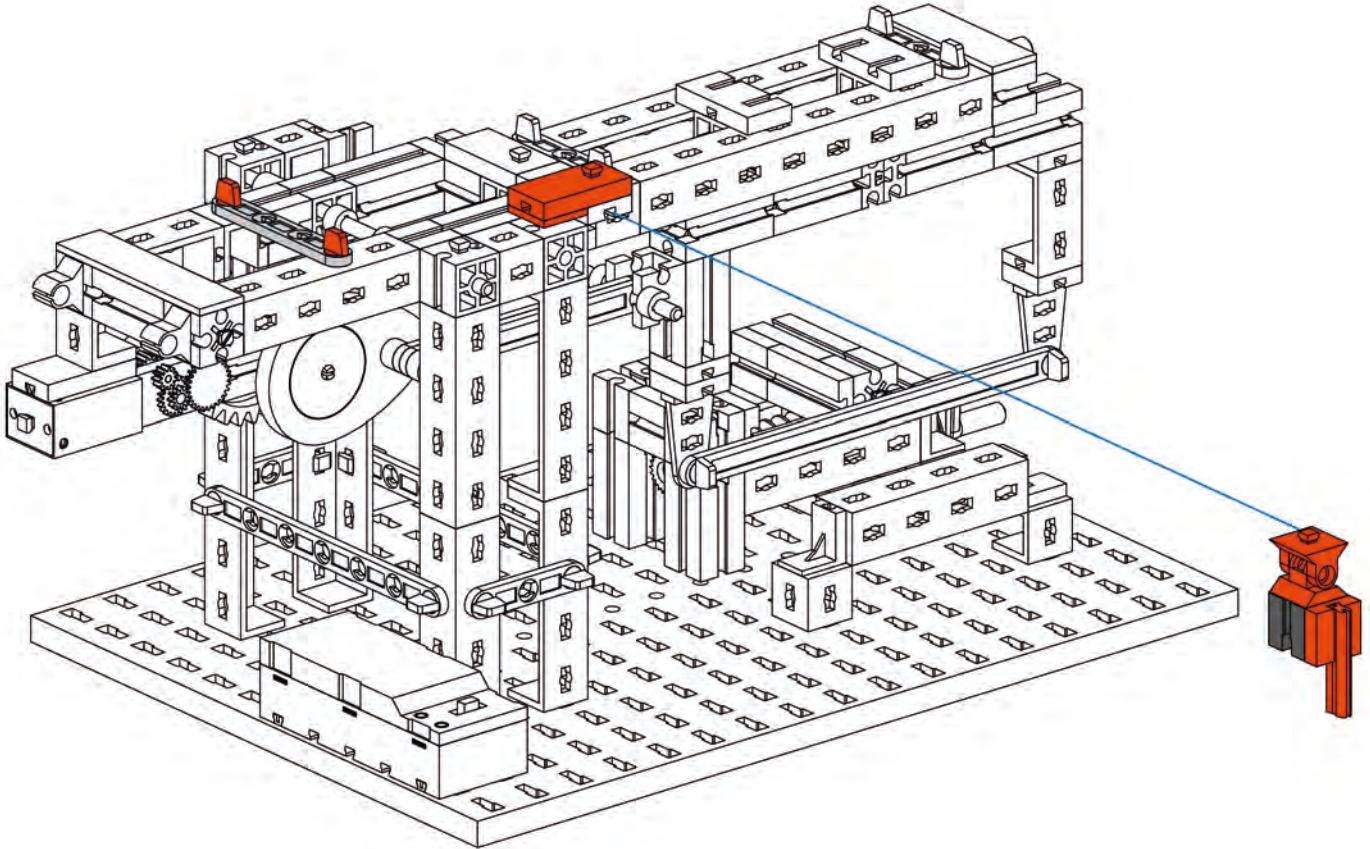

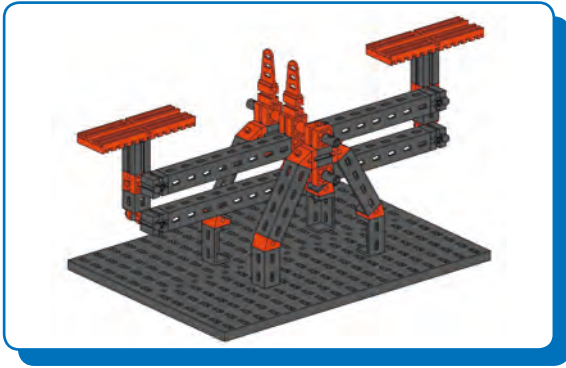

Balkenwaage
Beam and scales
Crochet-bascule

Balansweegschaal
Balanza de brazos
Balança de pratos

Bilancia a braccio
Весы с коромыслом
天平

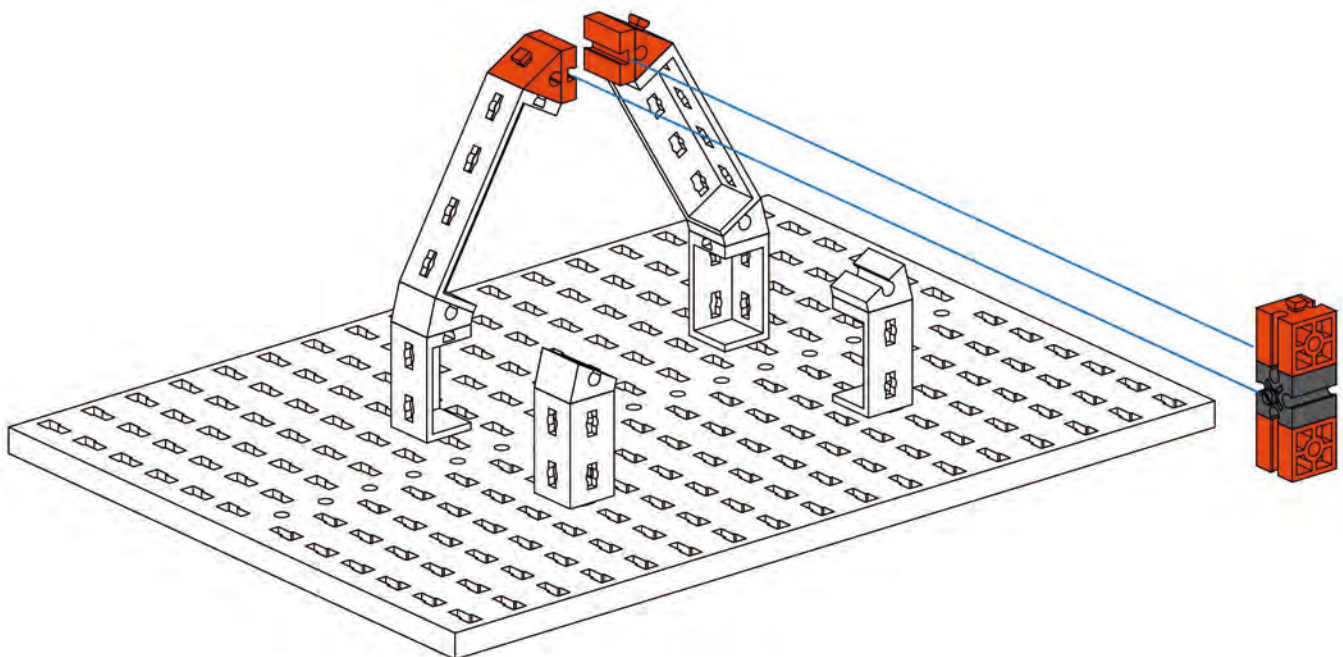
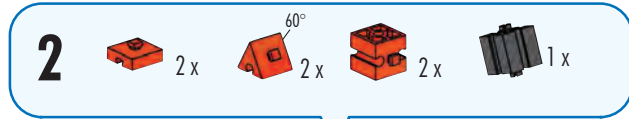
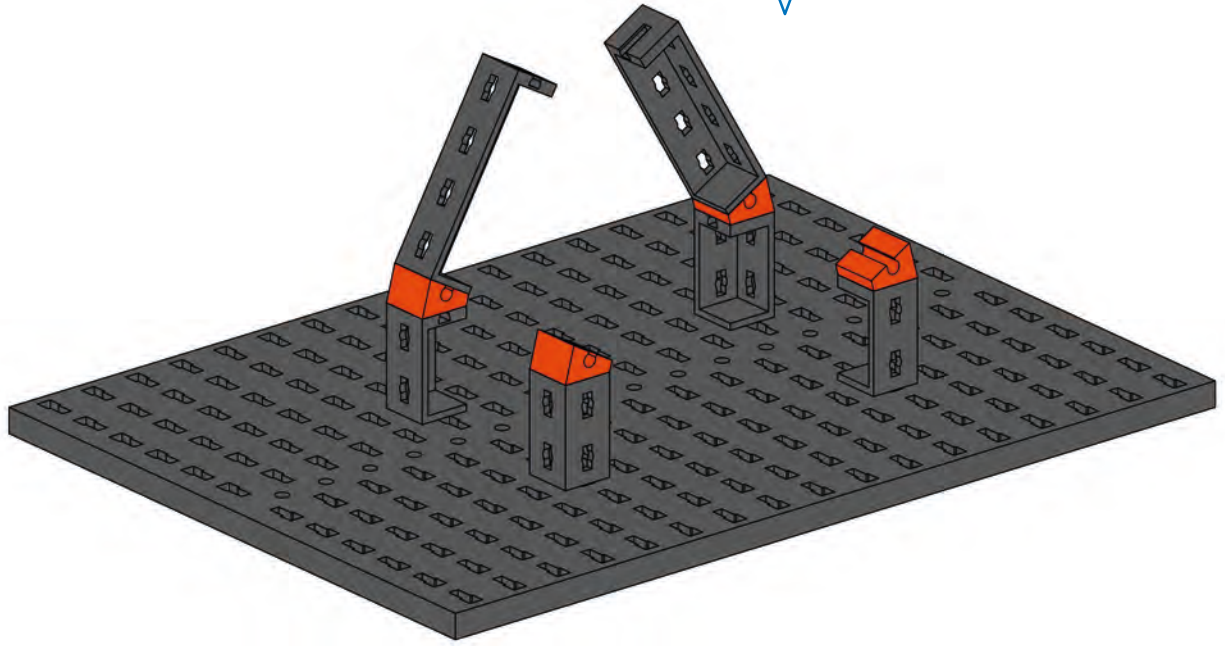
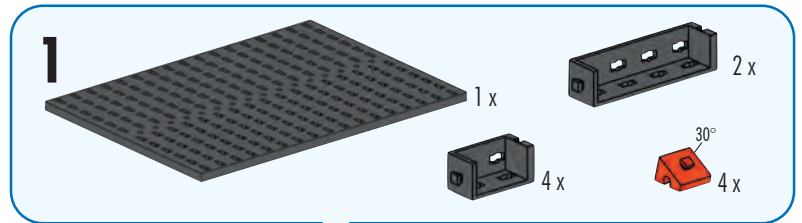

3

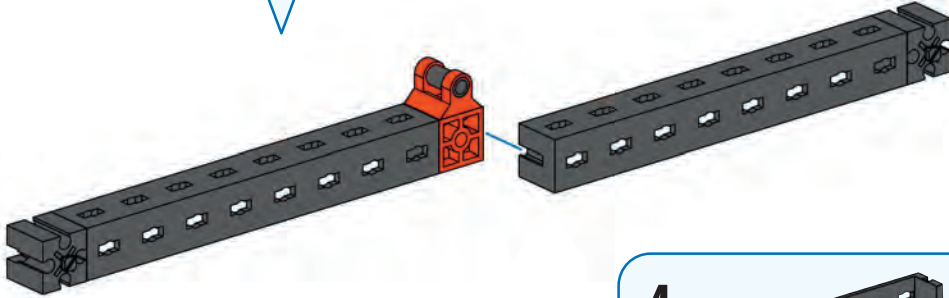
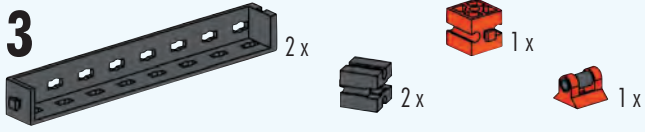

4

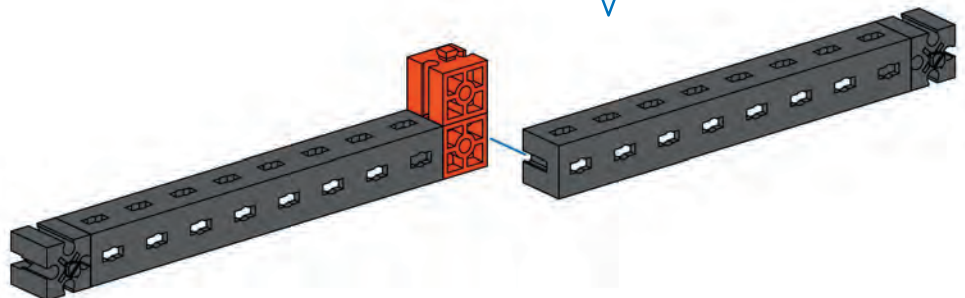
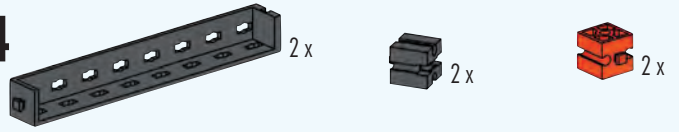

5

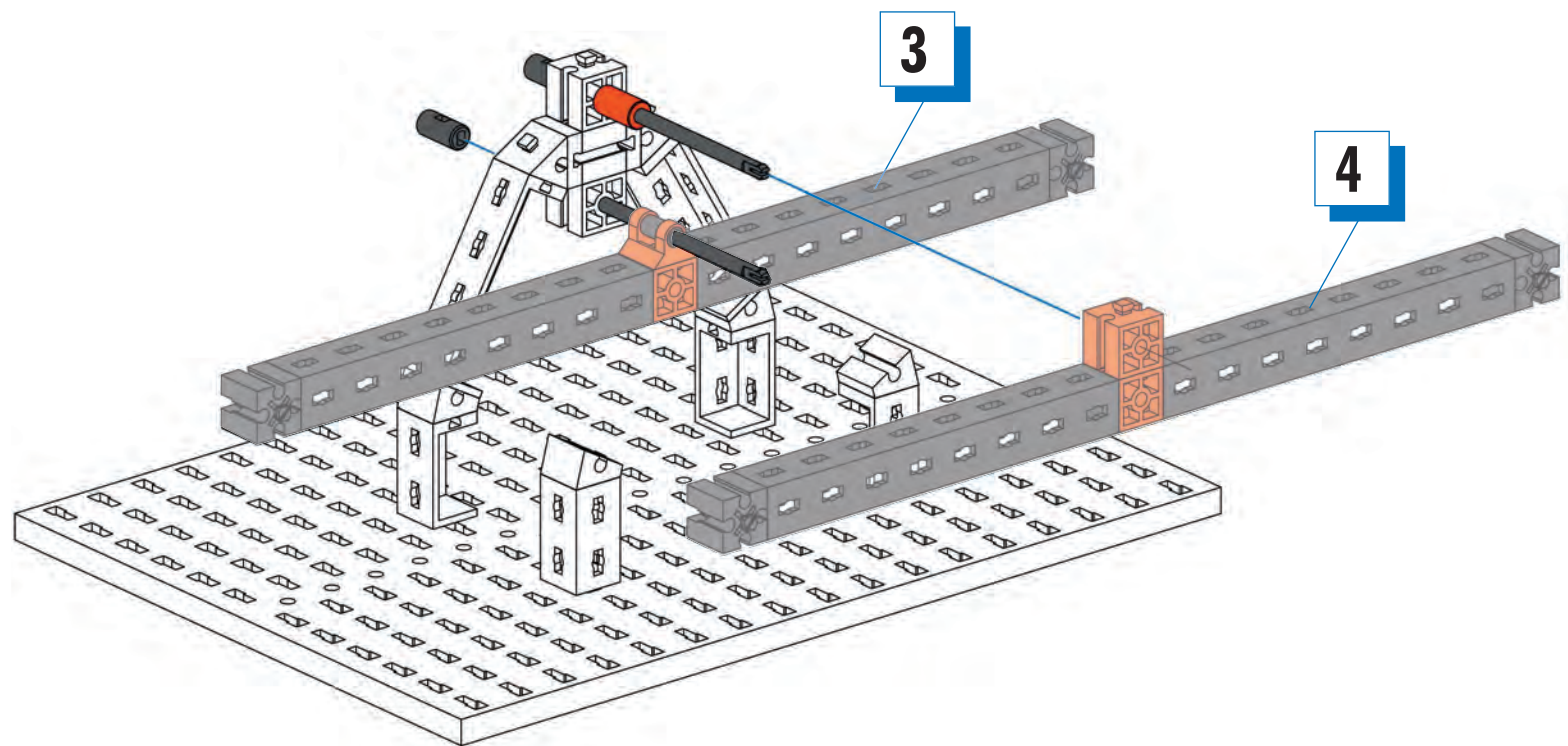
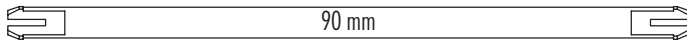



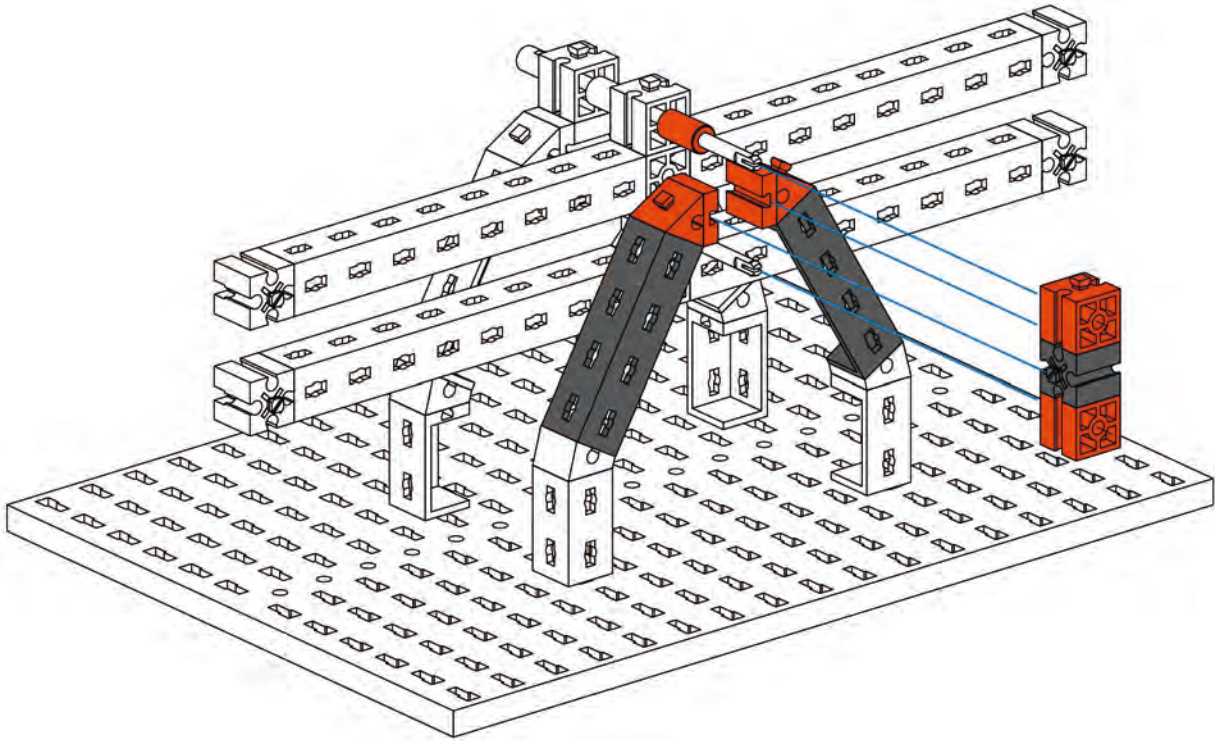

6



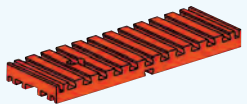

- 2 x 
- 2 x 
- 2 x 
- 2 x 
- 1 x 
- 1 x 

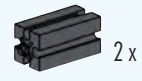

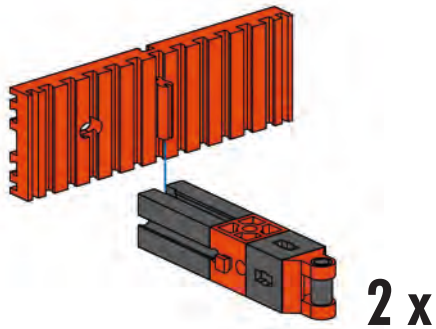
7

- 2 x 
- 2 x 
- 2 x 
- 2 x 
- 2 x 



- 8**  4x  2x  2x  2x

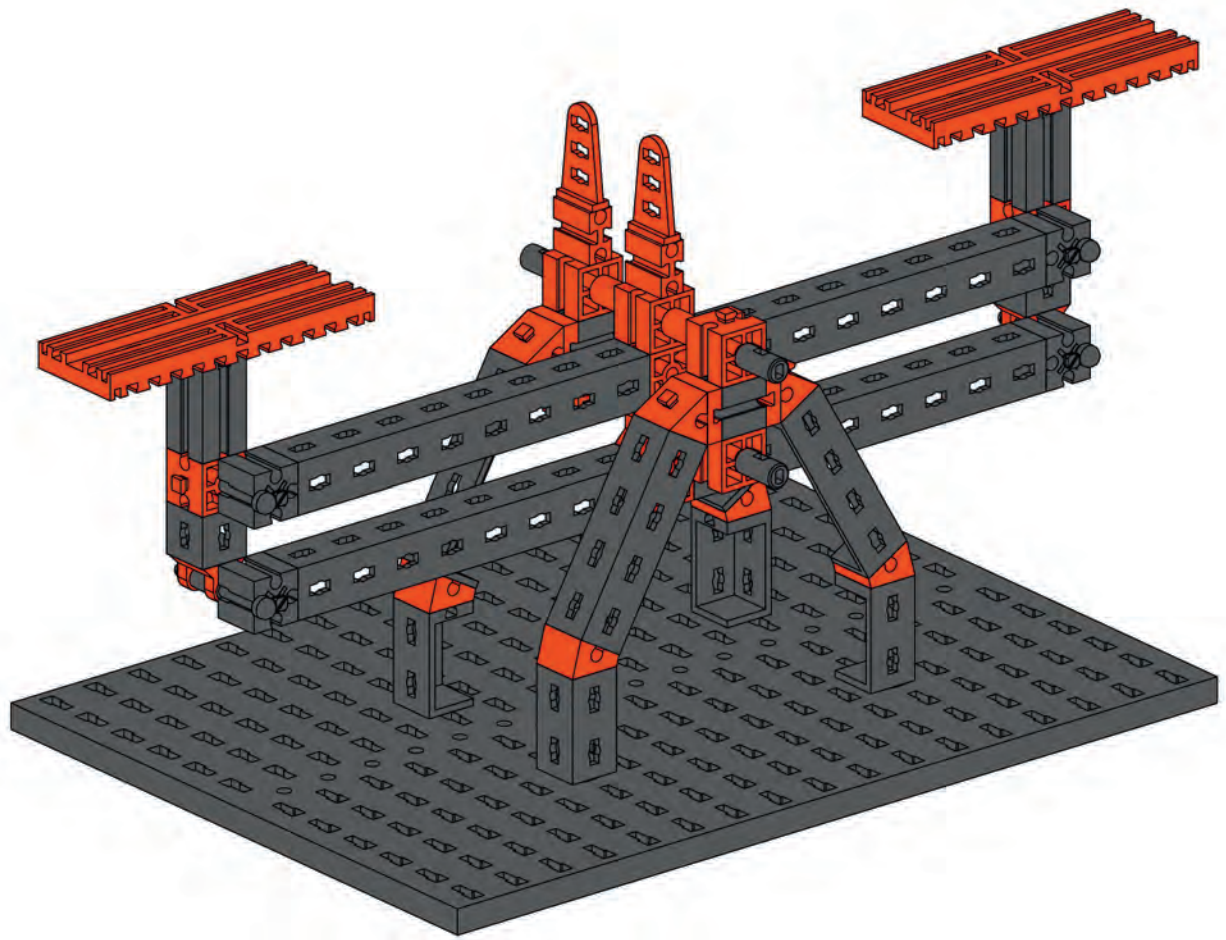
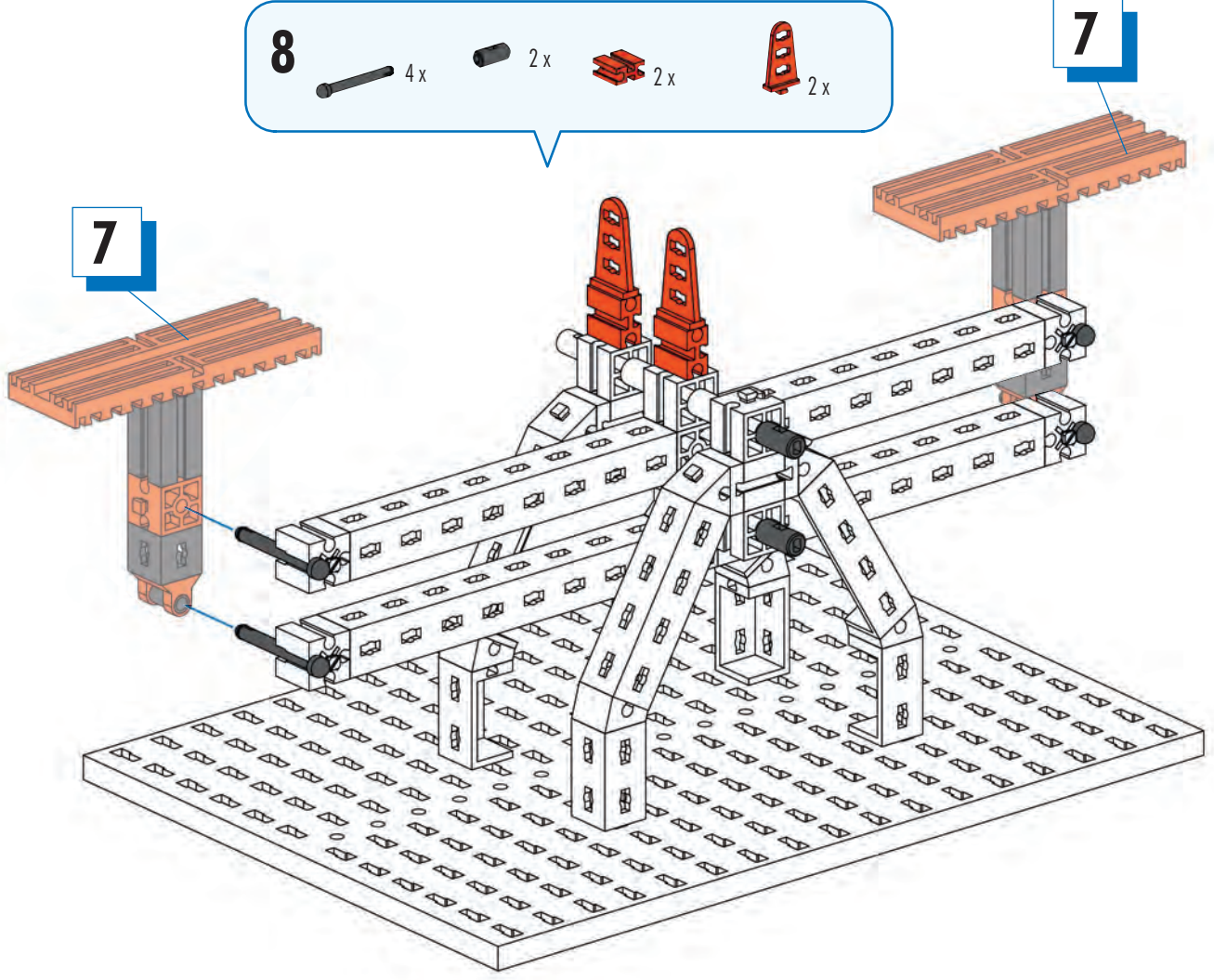

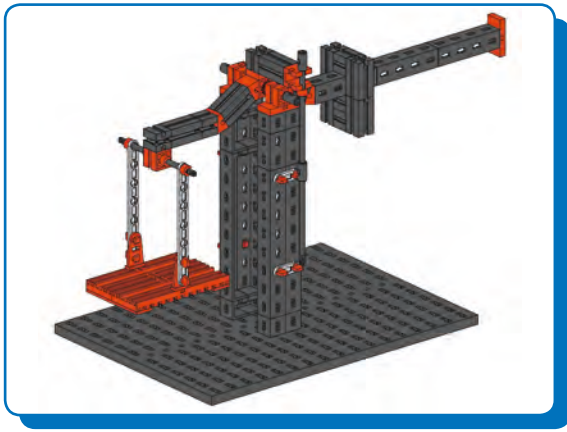



Waage mit Laufgewicht
Scales with sliding weight
Balance à poids mobile

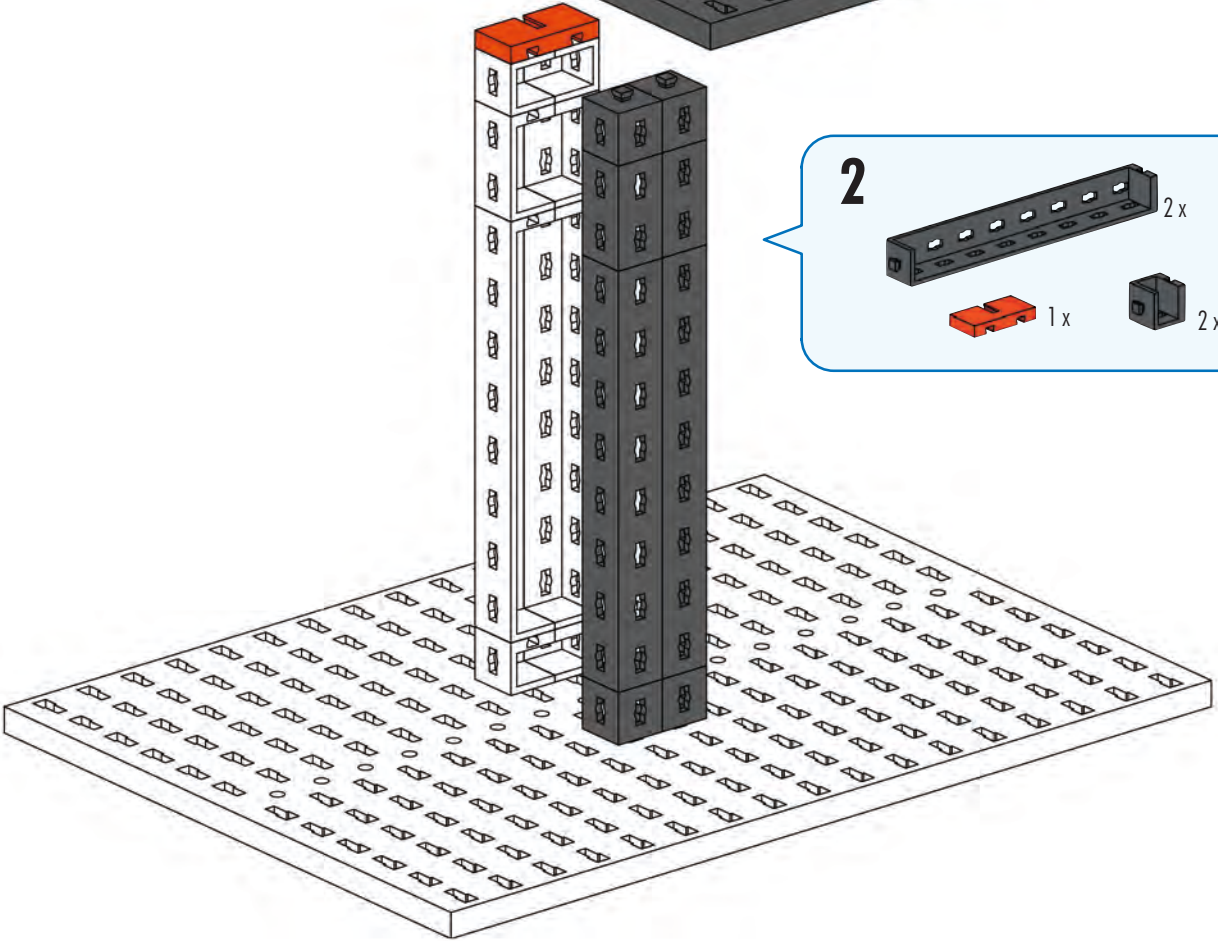
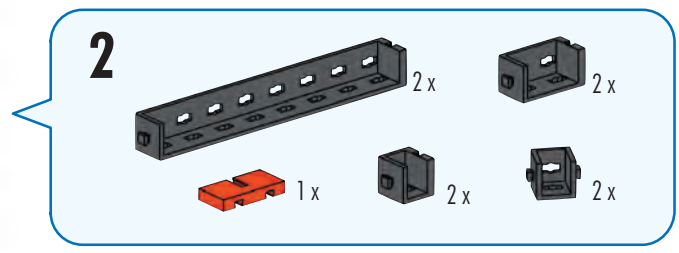
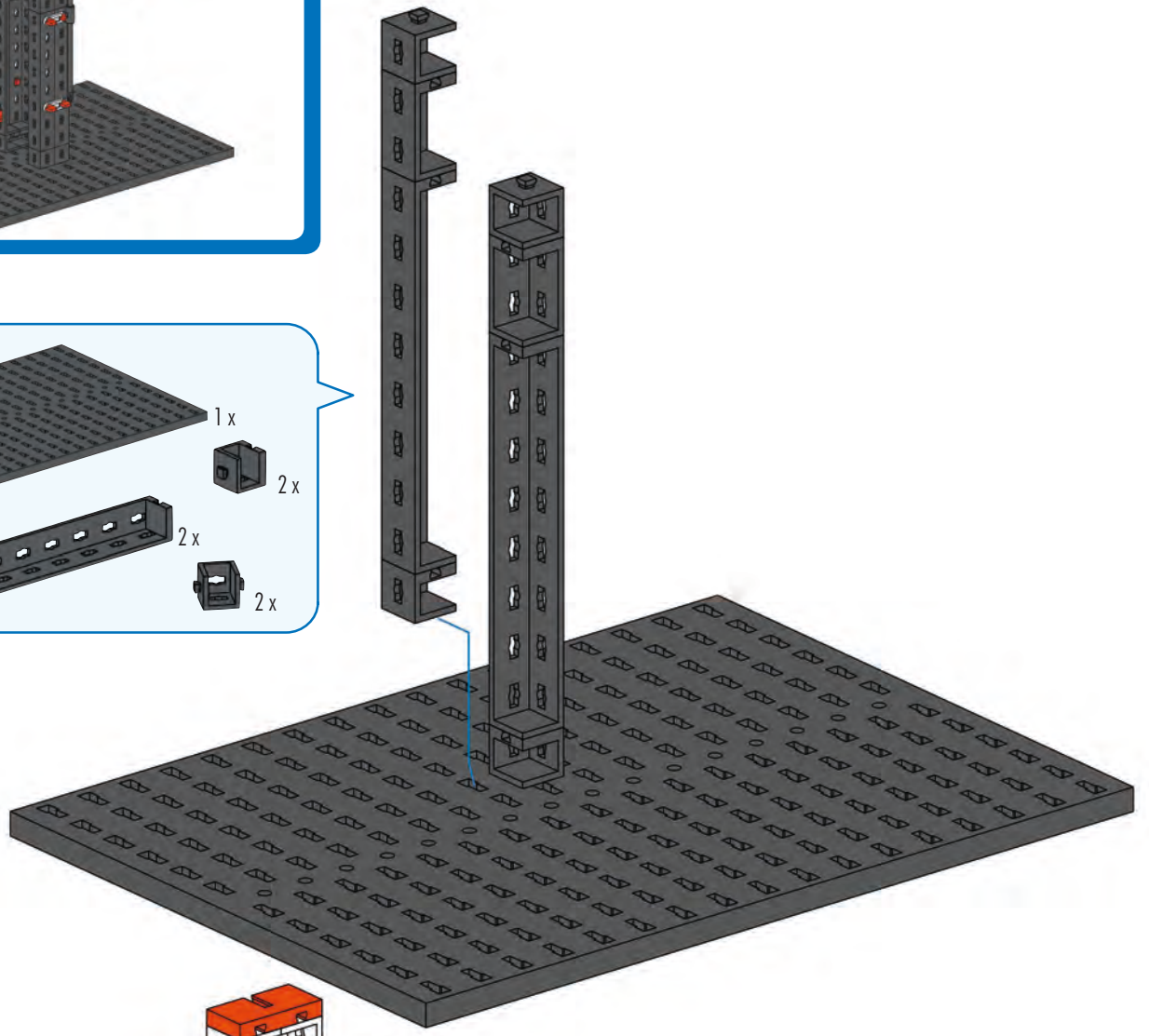
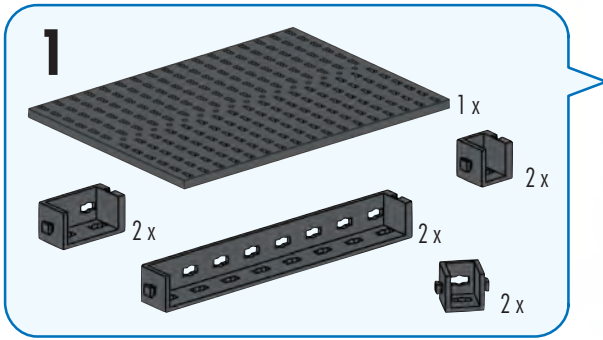

Weegschaal met schuifgewicht
Balanza con pesa corrediza
Balança com peso cursor

Bilancia con cursore
Весы с подвижным грузом
带滑动秤锤的天平





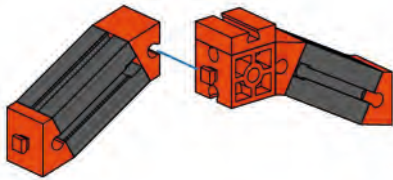
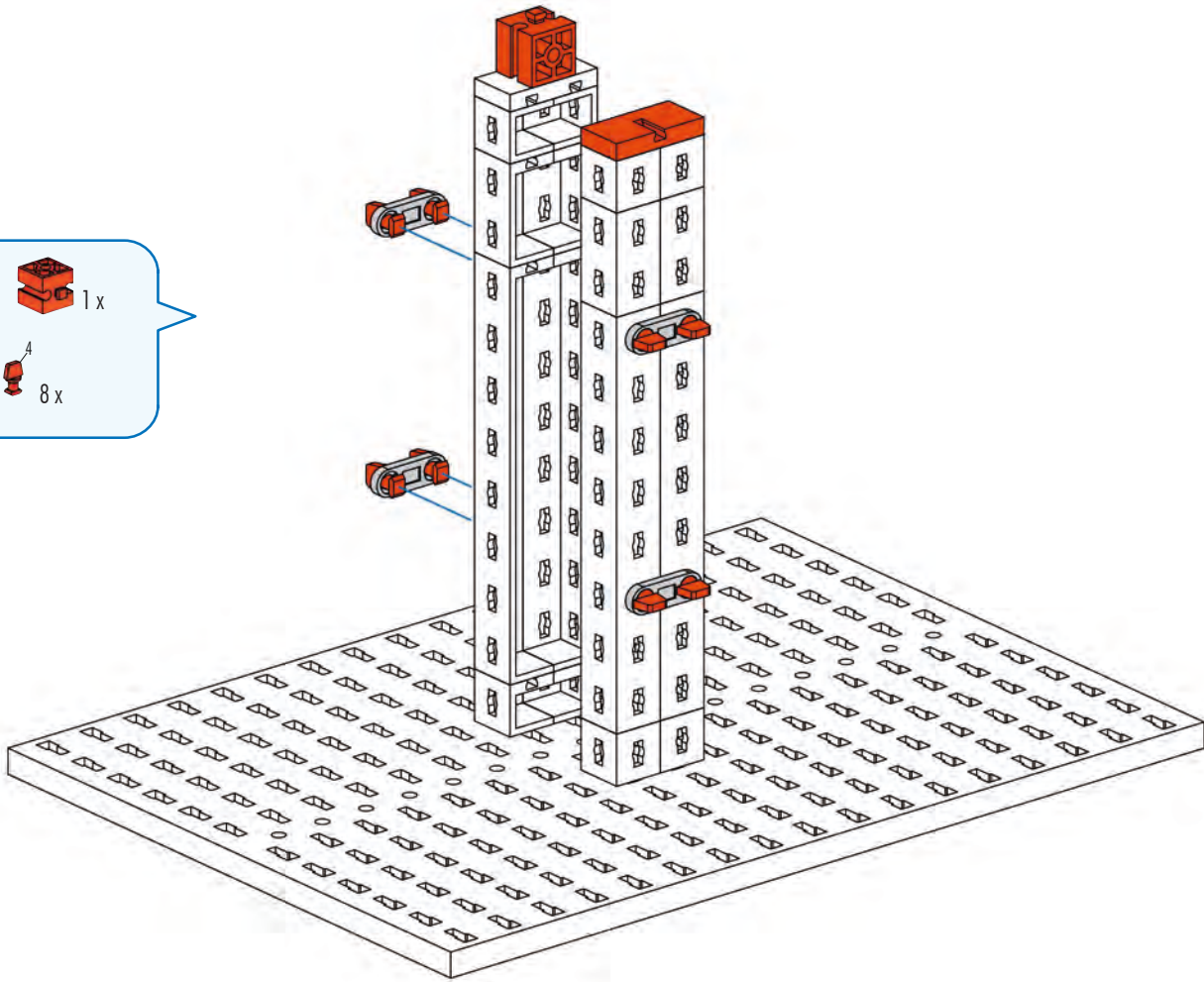

3

1x  1x 



4x  8x 



4

2x  1x  1x  4x 

5

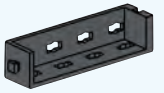
1x  2x  1x  3x 

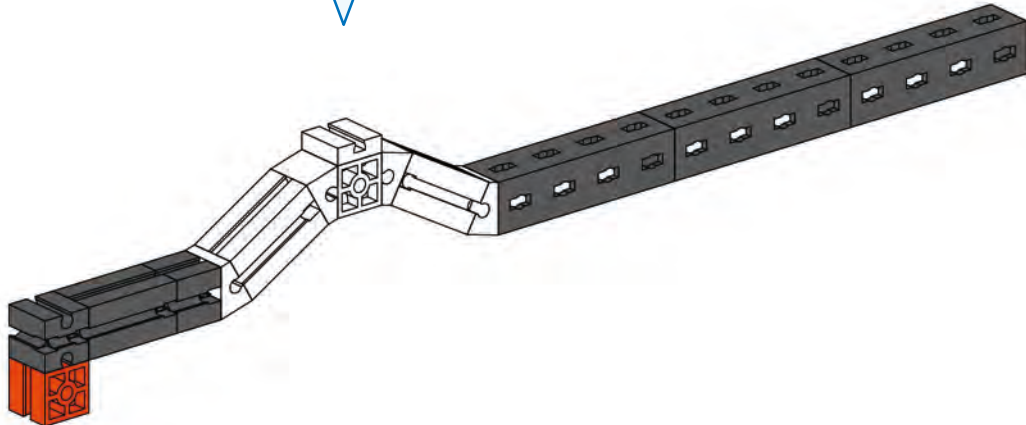

6 15 1x 3x 1x 2x 1x

75 mm

5

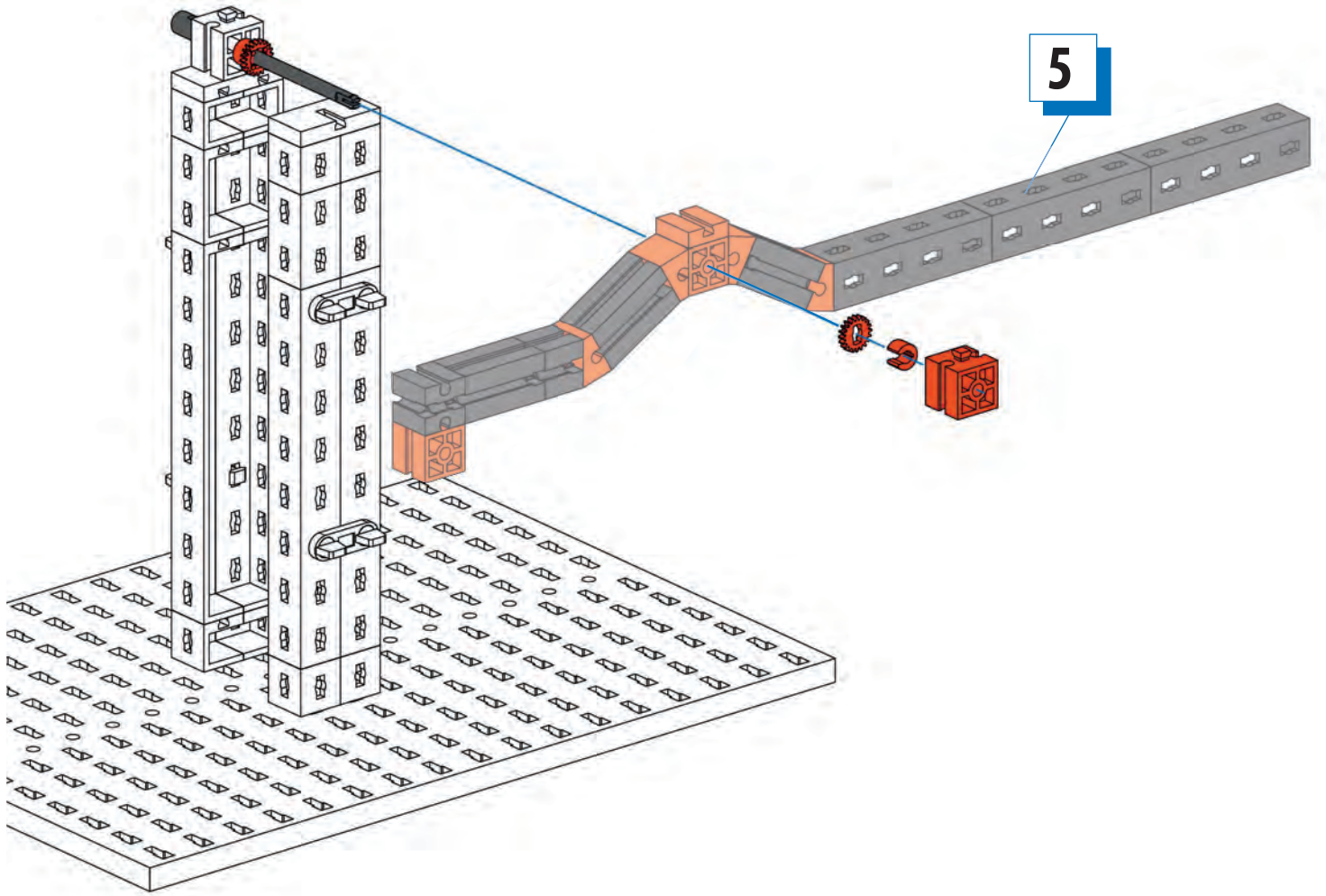

7 2x 90 2x 2x 4x 2x

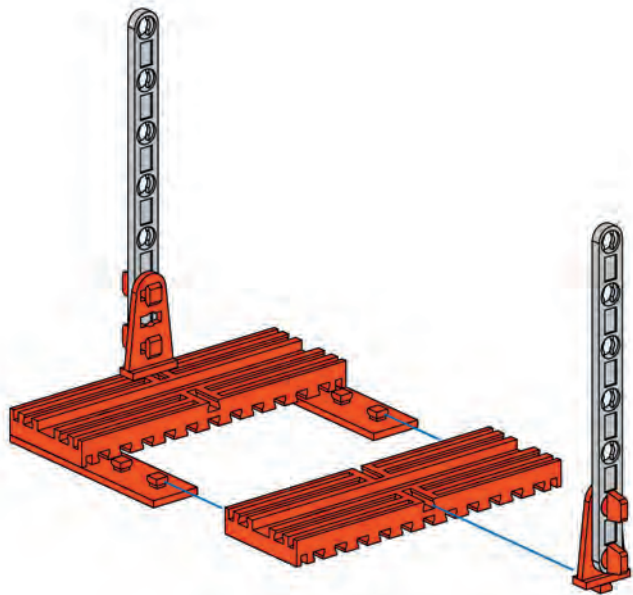

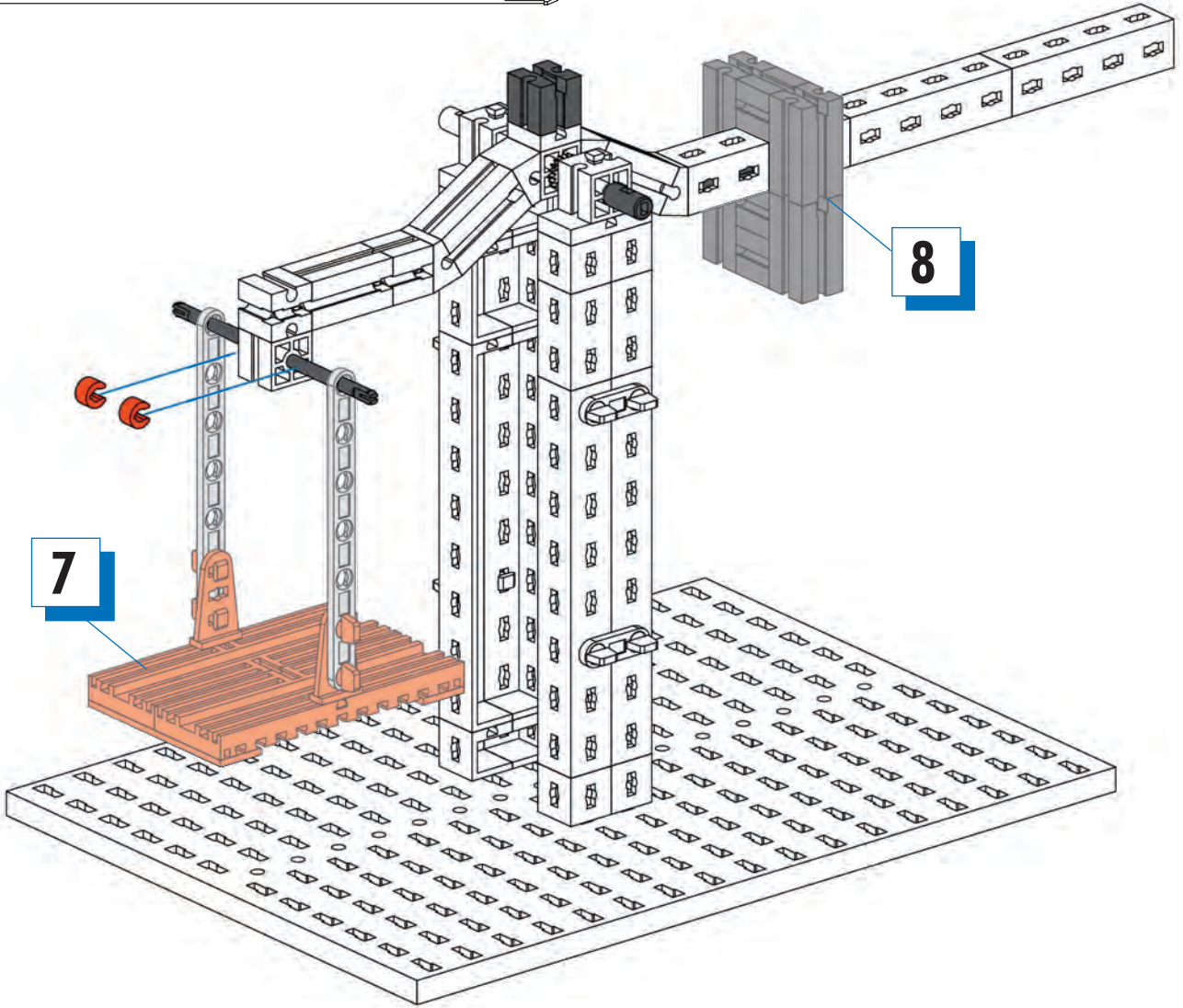
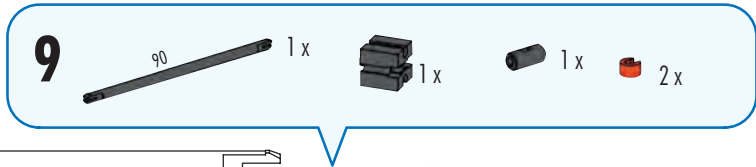
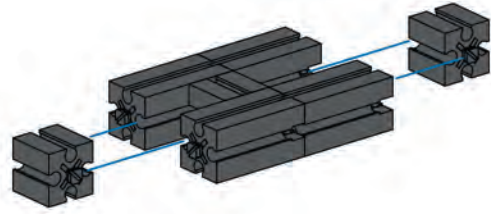
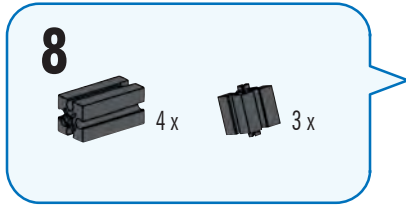

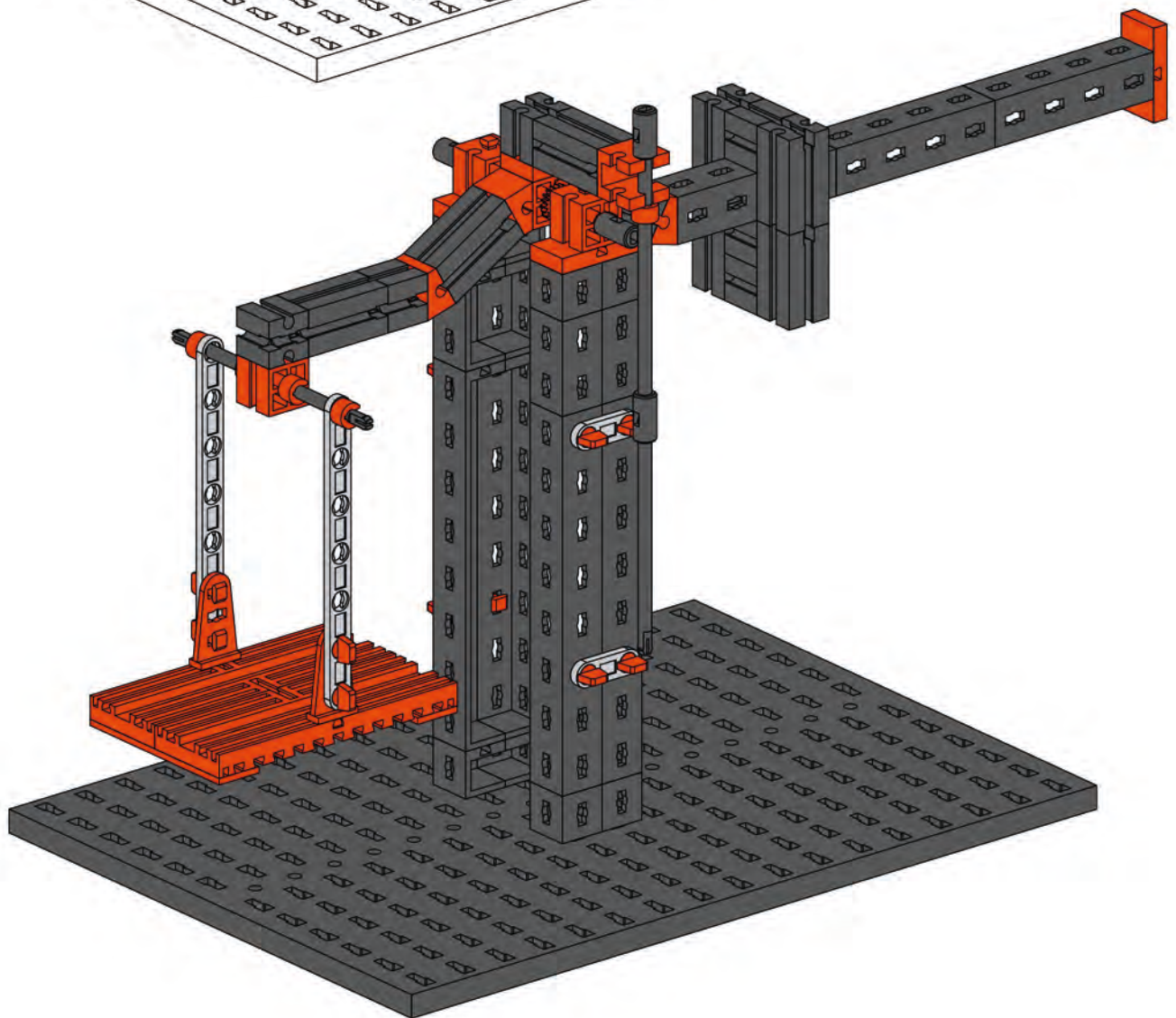
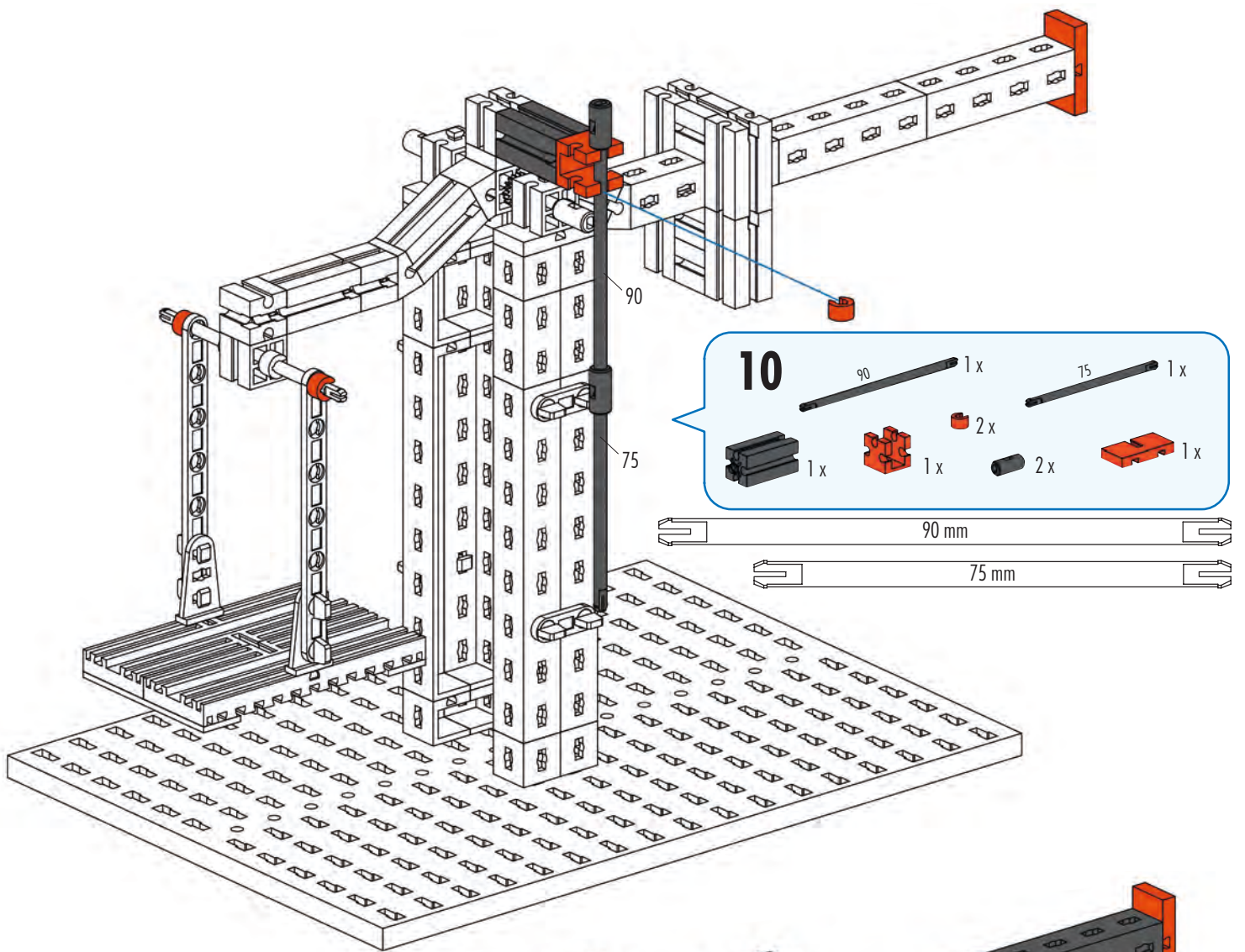

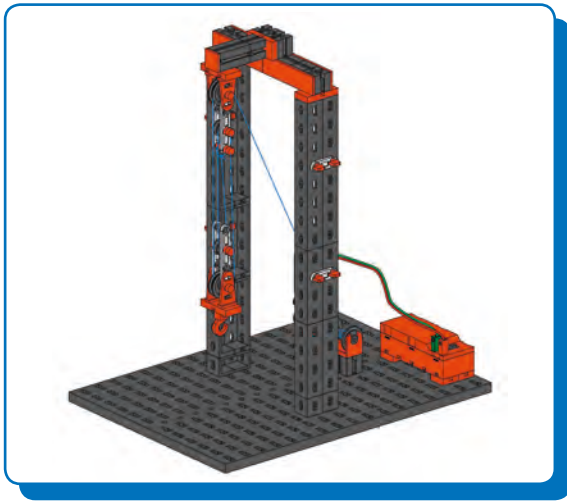



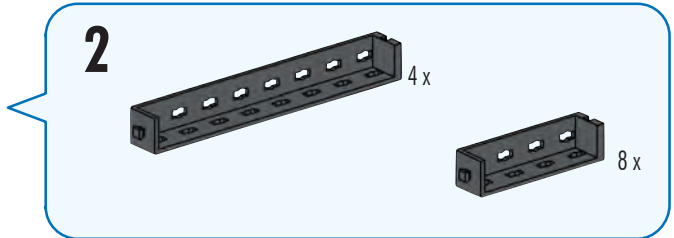
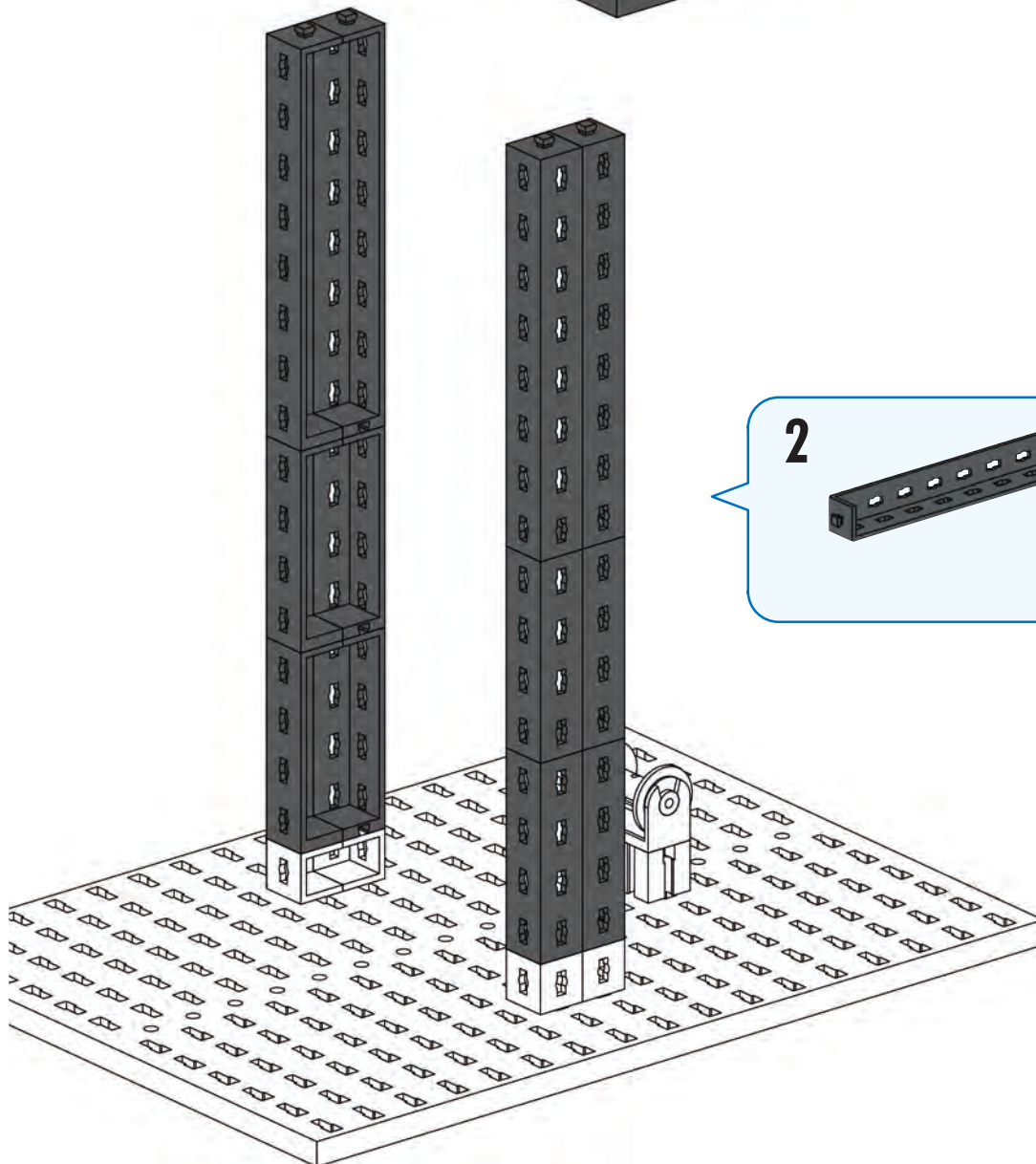
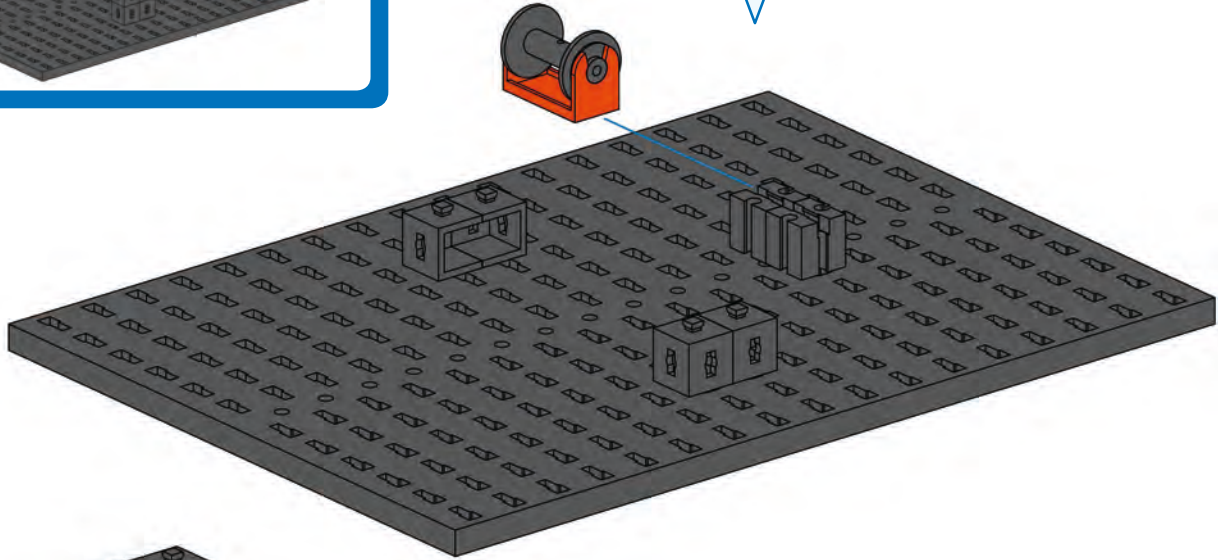
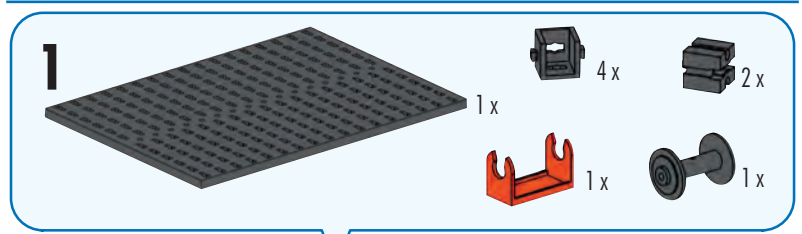

Flaschenzug
Lifting tackle
Palan

Takel
Polipasto
Talha

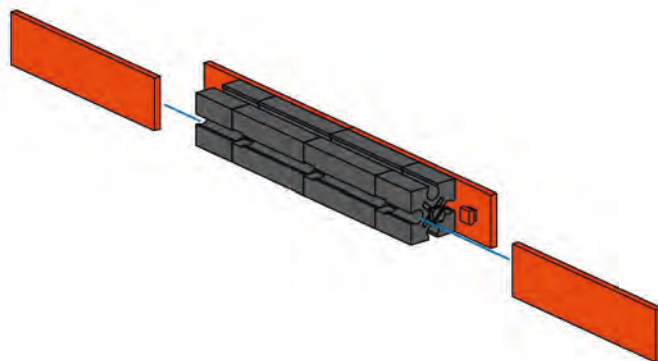
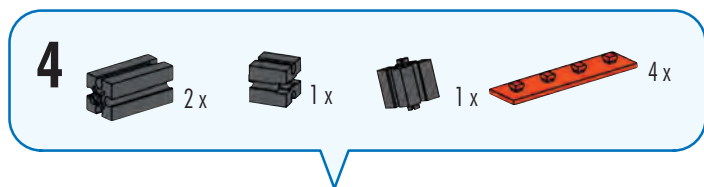
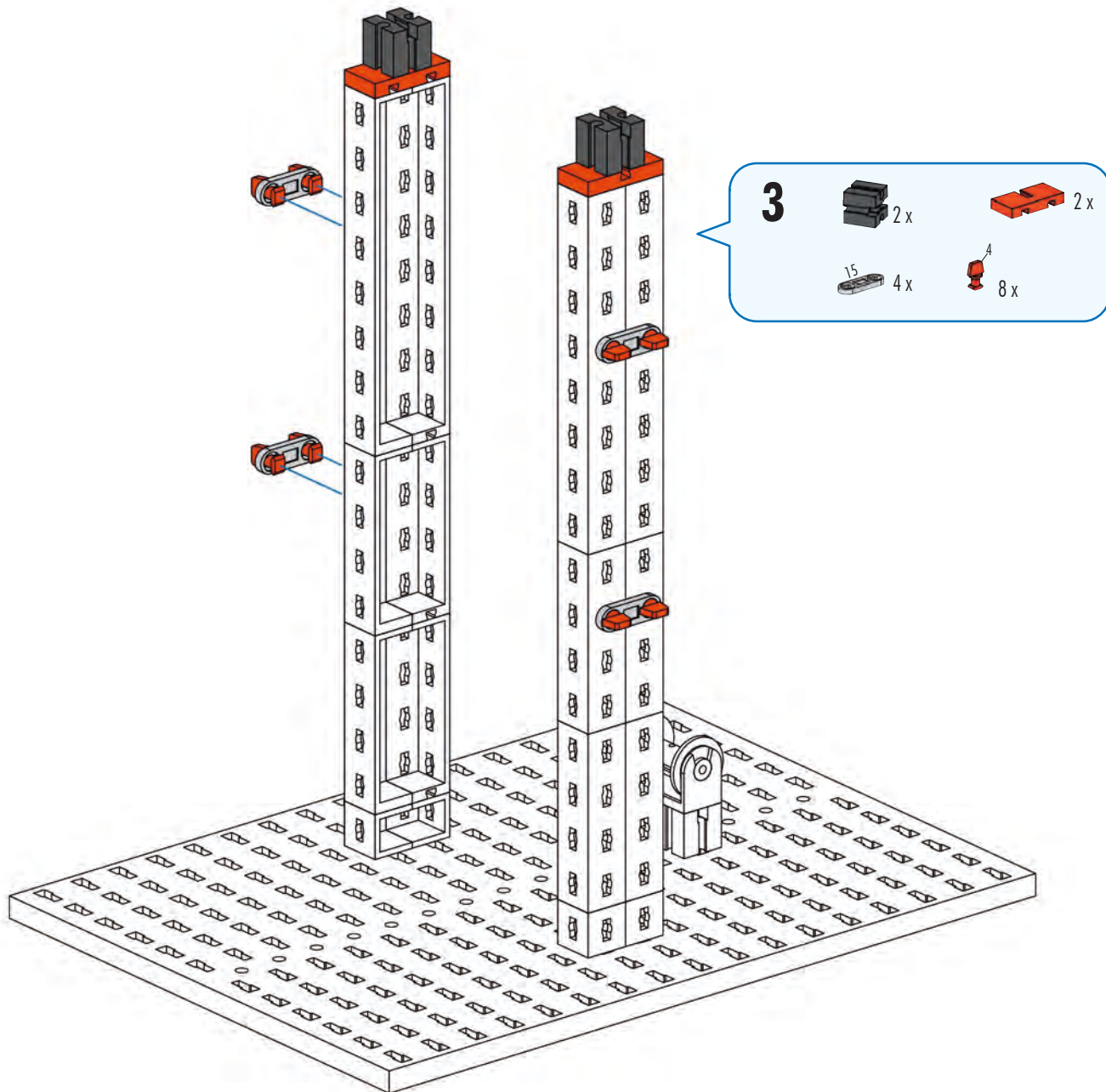
Paranco
Таль
滑轮组





5  2x  1x  2x

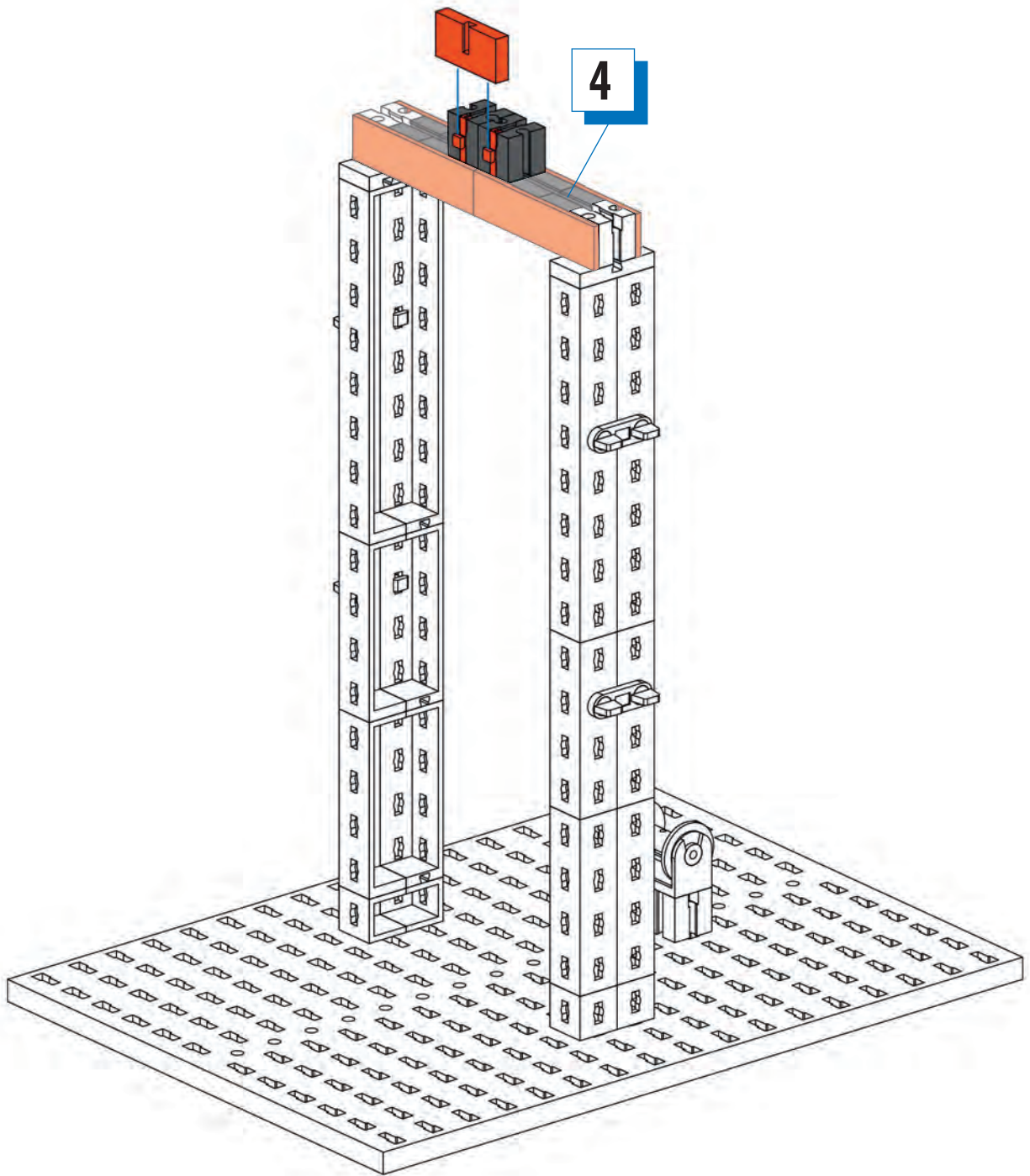

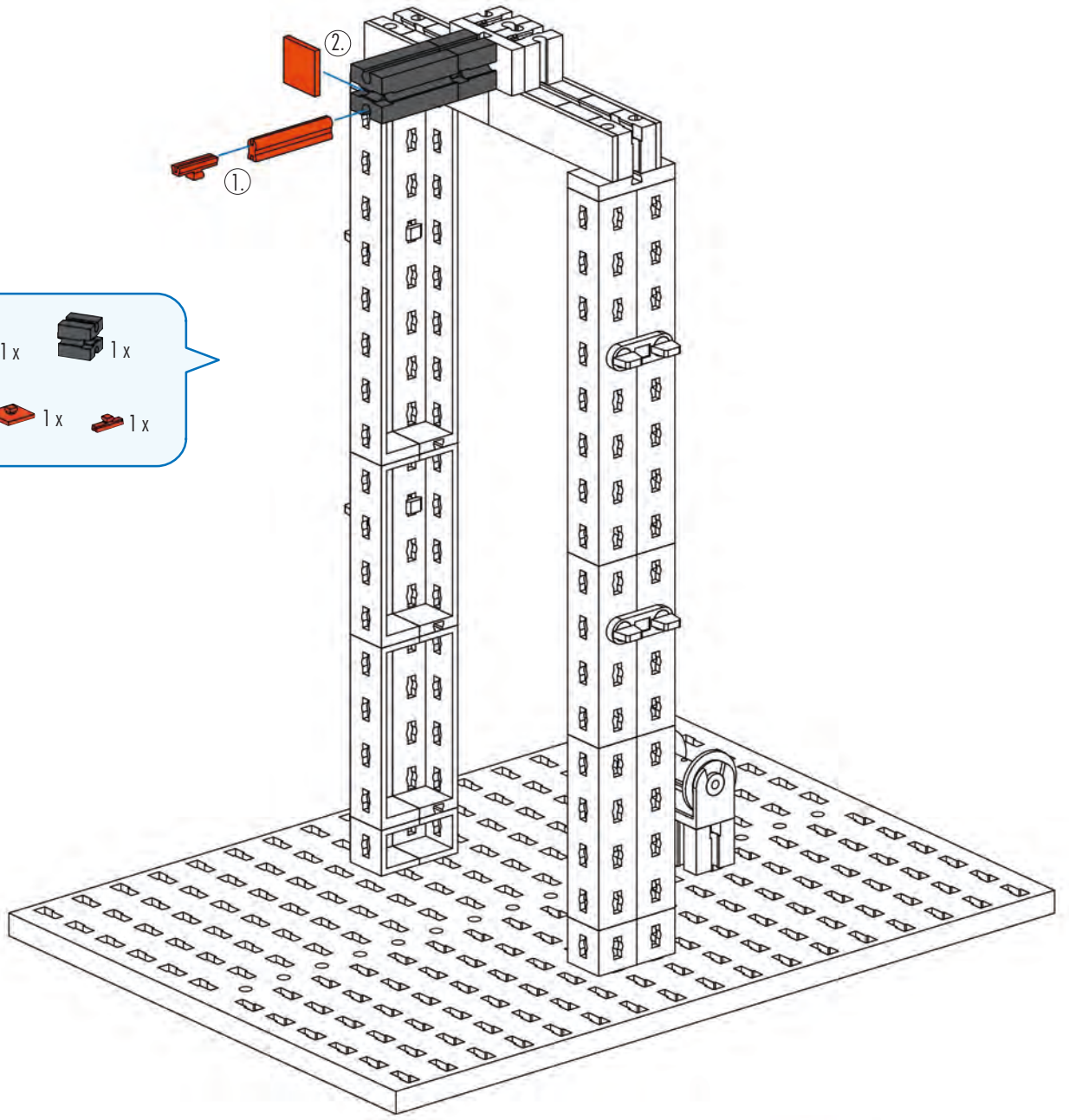

6

- 1x [Black Technic Beam 1x3]
- 1x [Black Technic Beam 1x3]
- 1x [Red Technic Beam 1x30]
- 1x [Red Technic Plate 1x3]
- 1x [Red Technic Pin]

7

- 4x [Red Technic Support]
- 2x [Black Technic Wheel]
- 4x [Grey Technic Beam 1x45]
- 2x [Red Technic Pin]

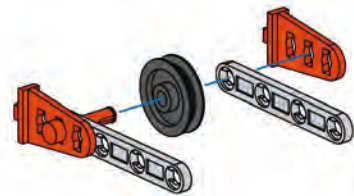

2 x

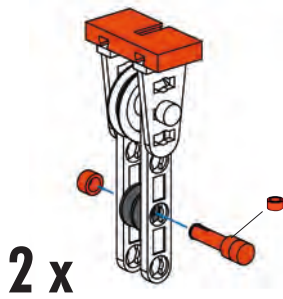

2 x

8

- 2x [Red Technic Support]
- 2x [Black Technic Wheel]
- 4x [Red Technic Pin]
- 2x [Red Technic Pin]

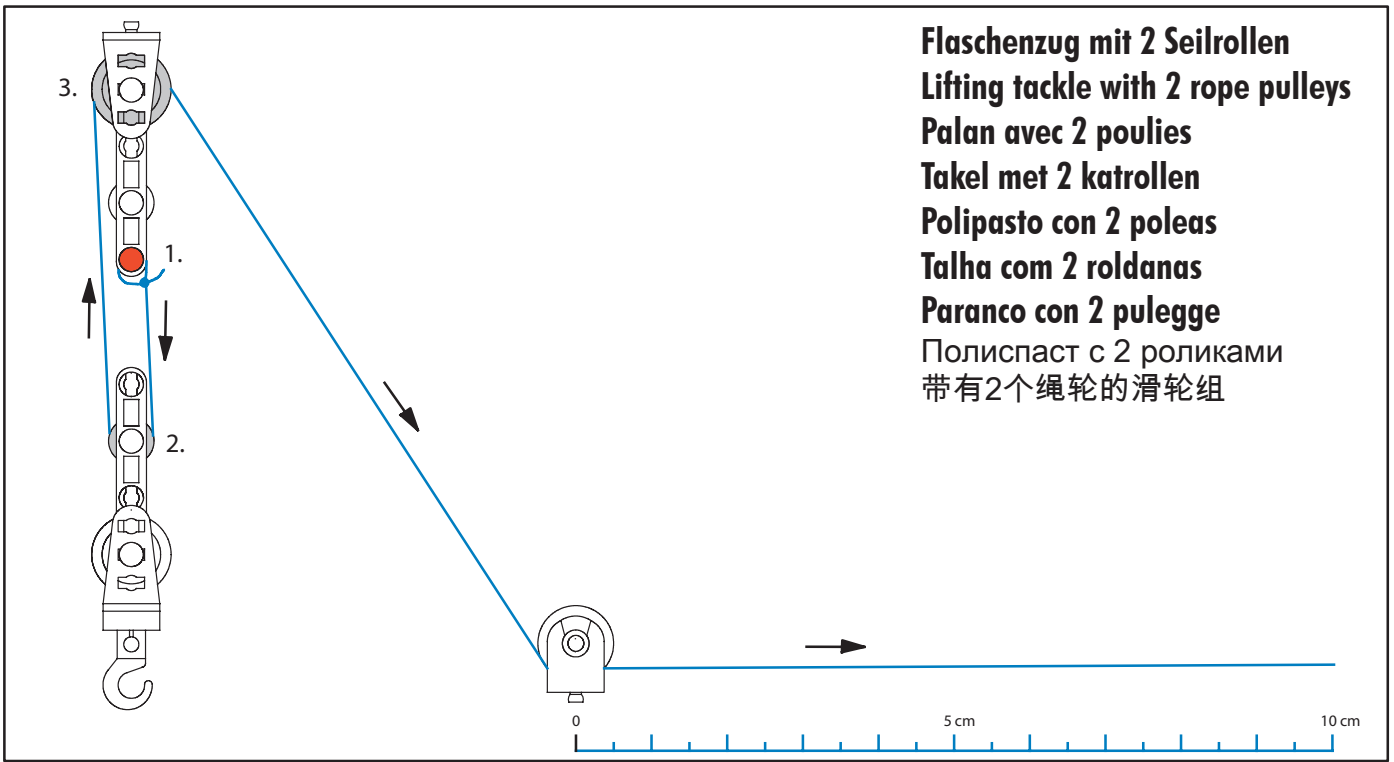

Flaschenzug mit 2 Seilrollen
 Lifting tackle with 2 rope pulleys
 Palan avec 2 poulies
 Takel met 2 katrollen
 Polipasto con 2 poleas
 Talha com 2 roldanas
 Paranco con 2 pulegge
 Полиспаст с 2 роликами
 带有2个绳轮的滑轮组

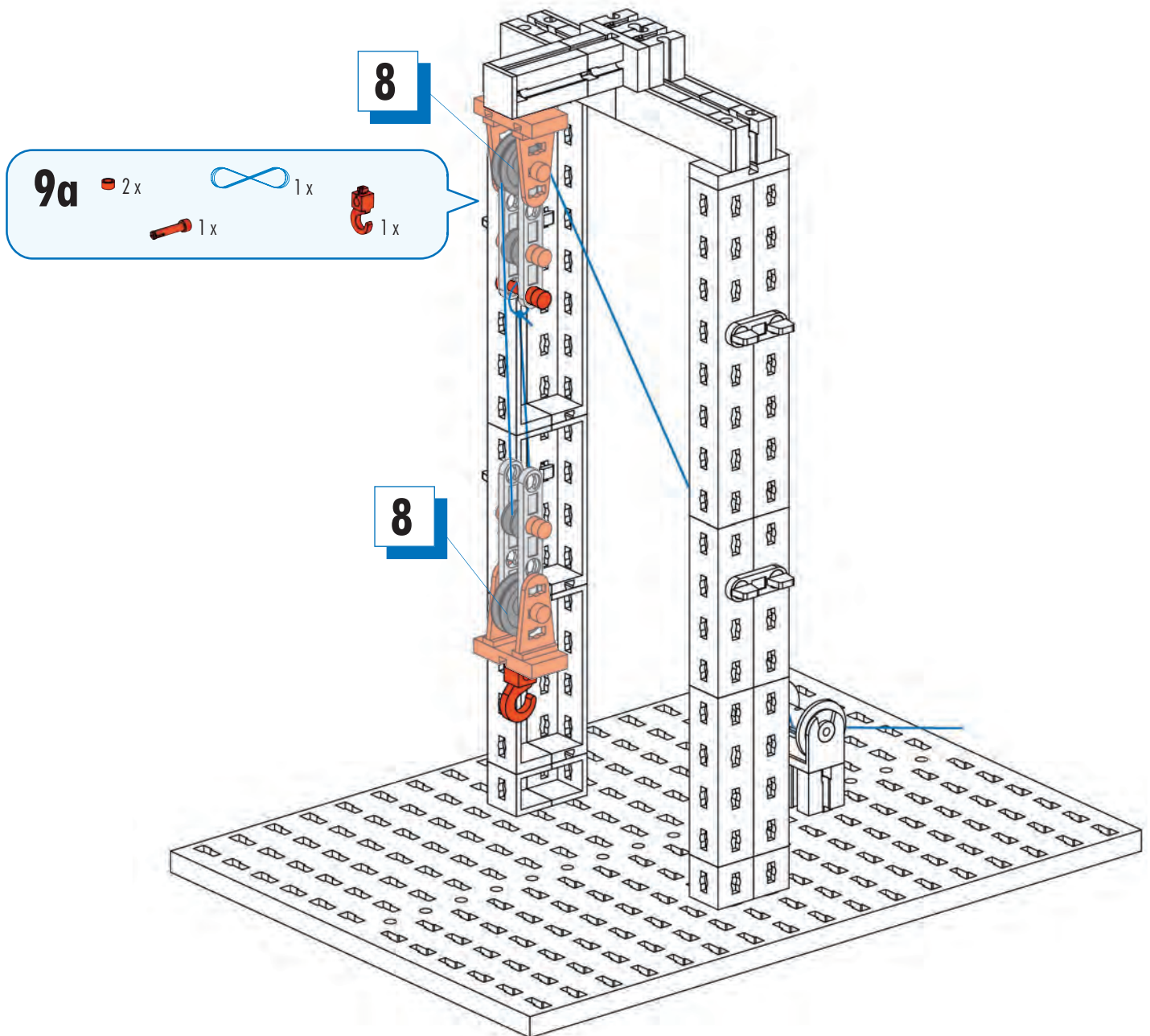

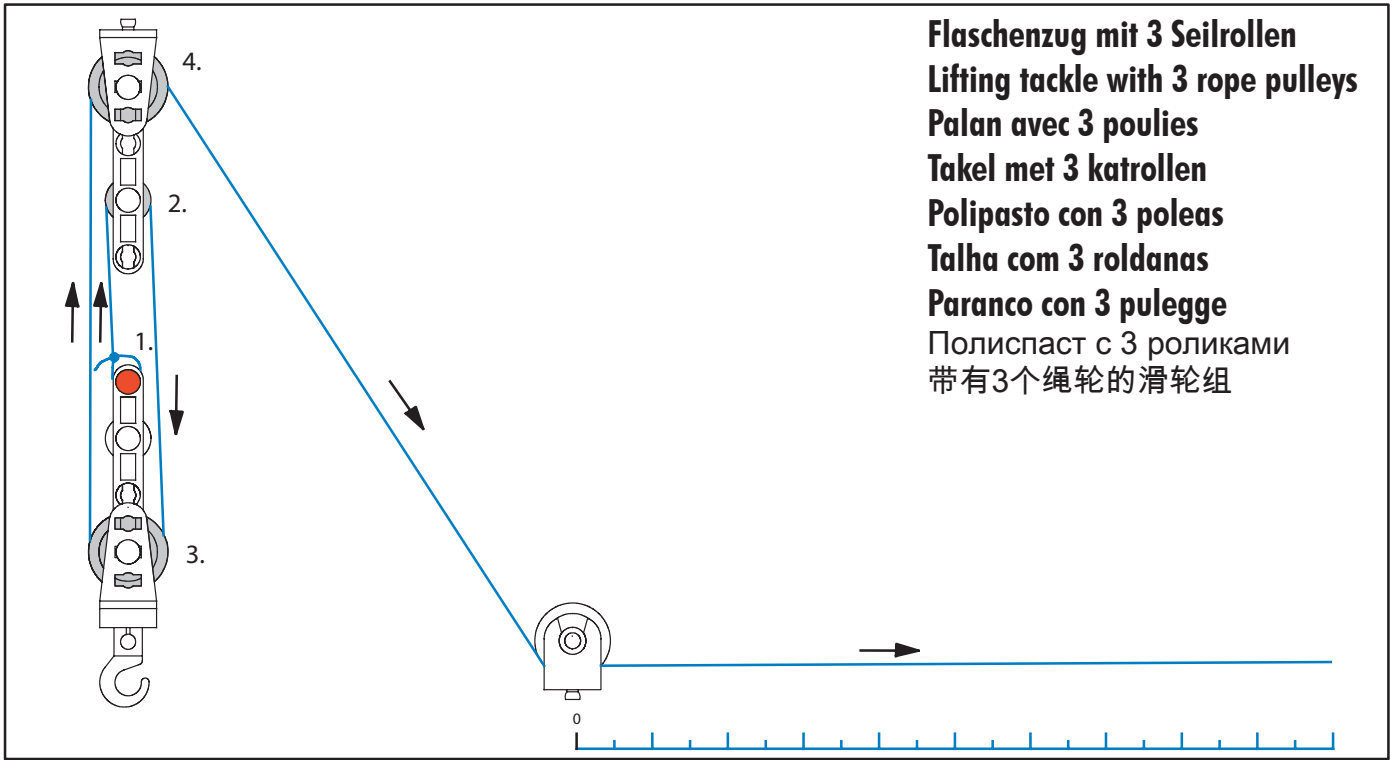

Flaschenzug mit 3 Seilrollen
 Lifting tackle with 3 rope pulleys
 Palan avec 3 poulies
 Takel met 3 katrollen
 Polipasto con 3 poleas
 Talha com 3 roldanas
 Paranco con 3 pulegge
 Полиспаст с 3 роликами
 带有3个绳轮的滑轮组

umbauen
 modify
 modifier
 veranderen
 modificar
 modificar
 modificare
 переделать
 改装

9a

9b

2 x

1 x

1 x

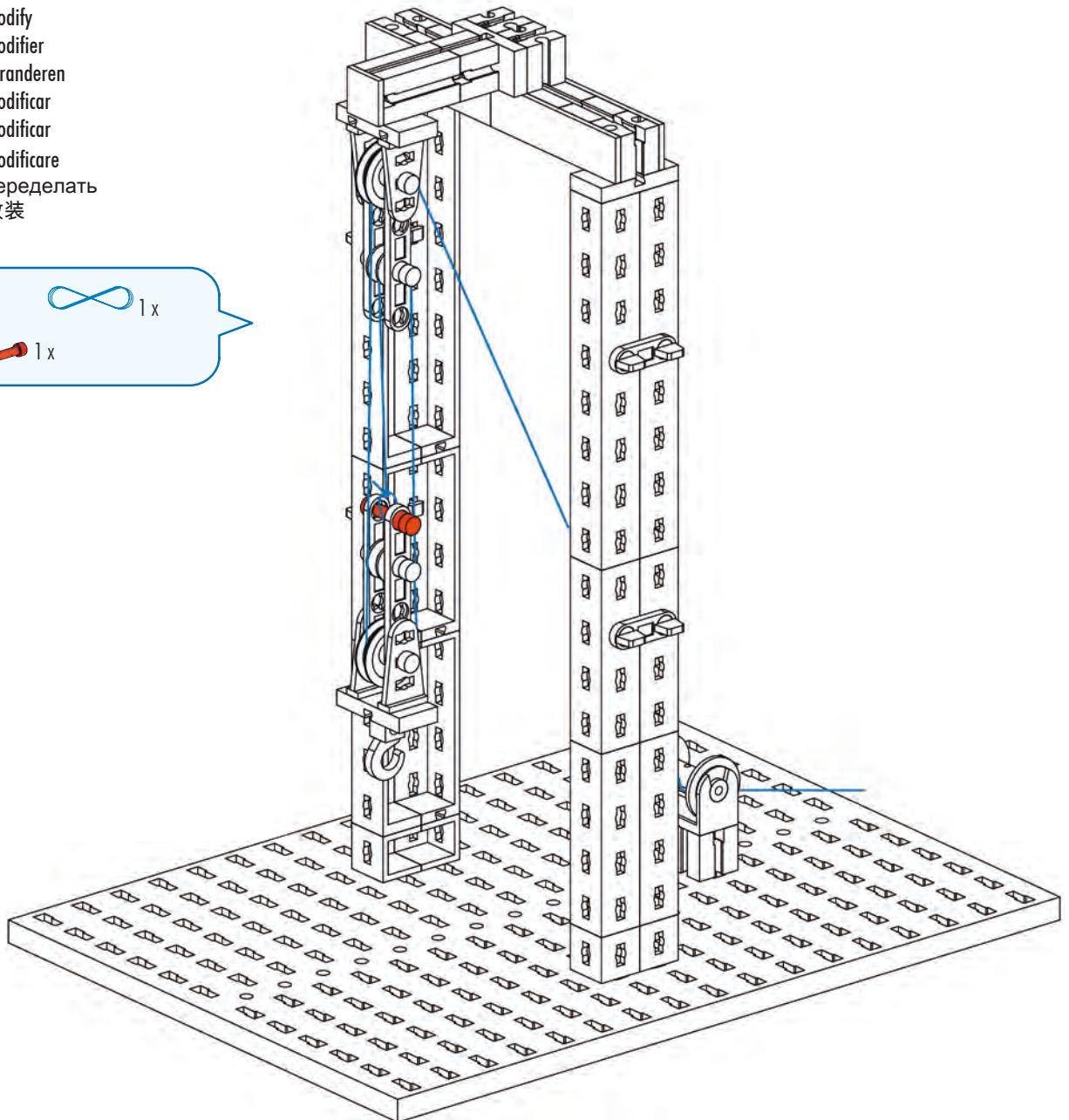

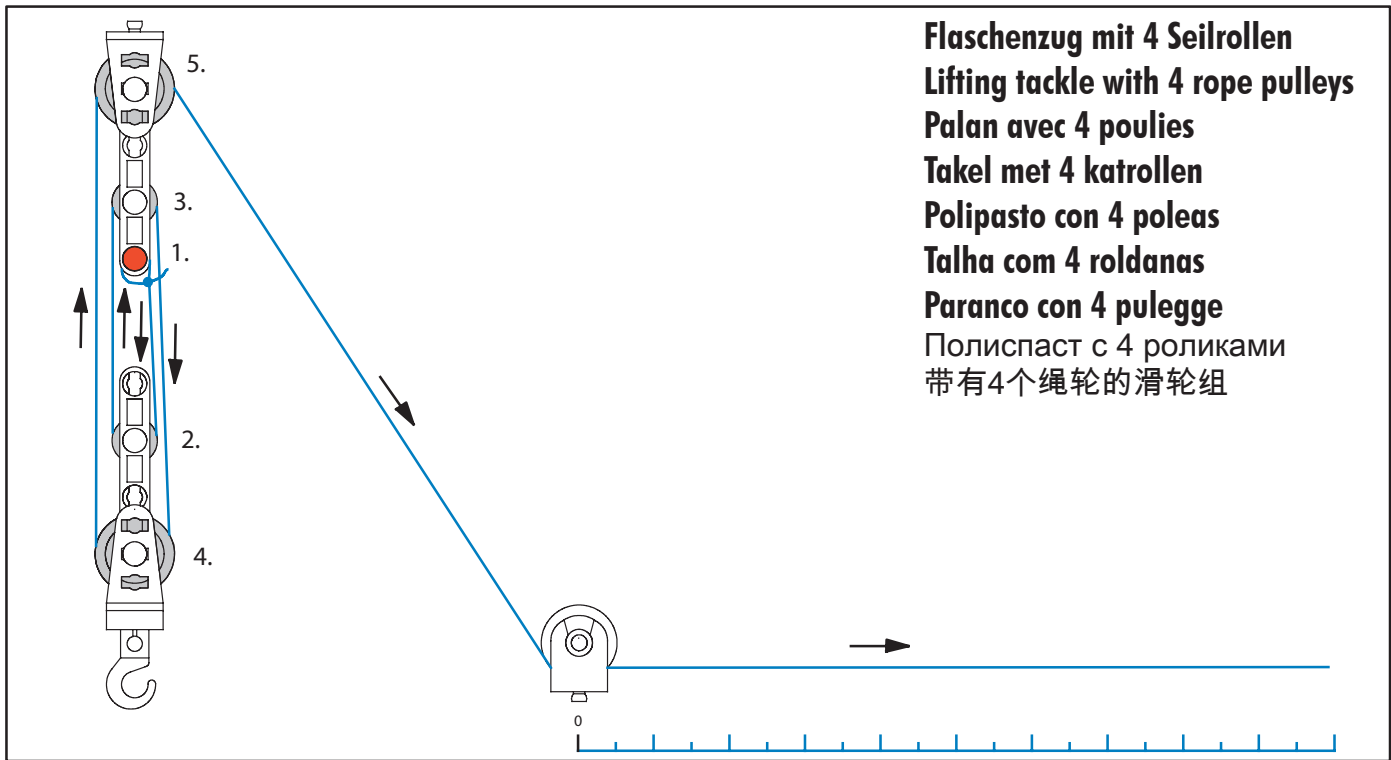

9b

umbauen
 modify
 modifier
 veranderen
 modificar
 modificar
 modificare
 переделать
 改装

9c

2 x



1 x



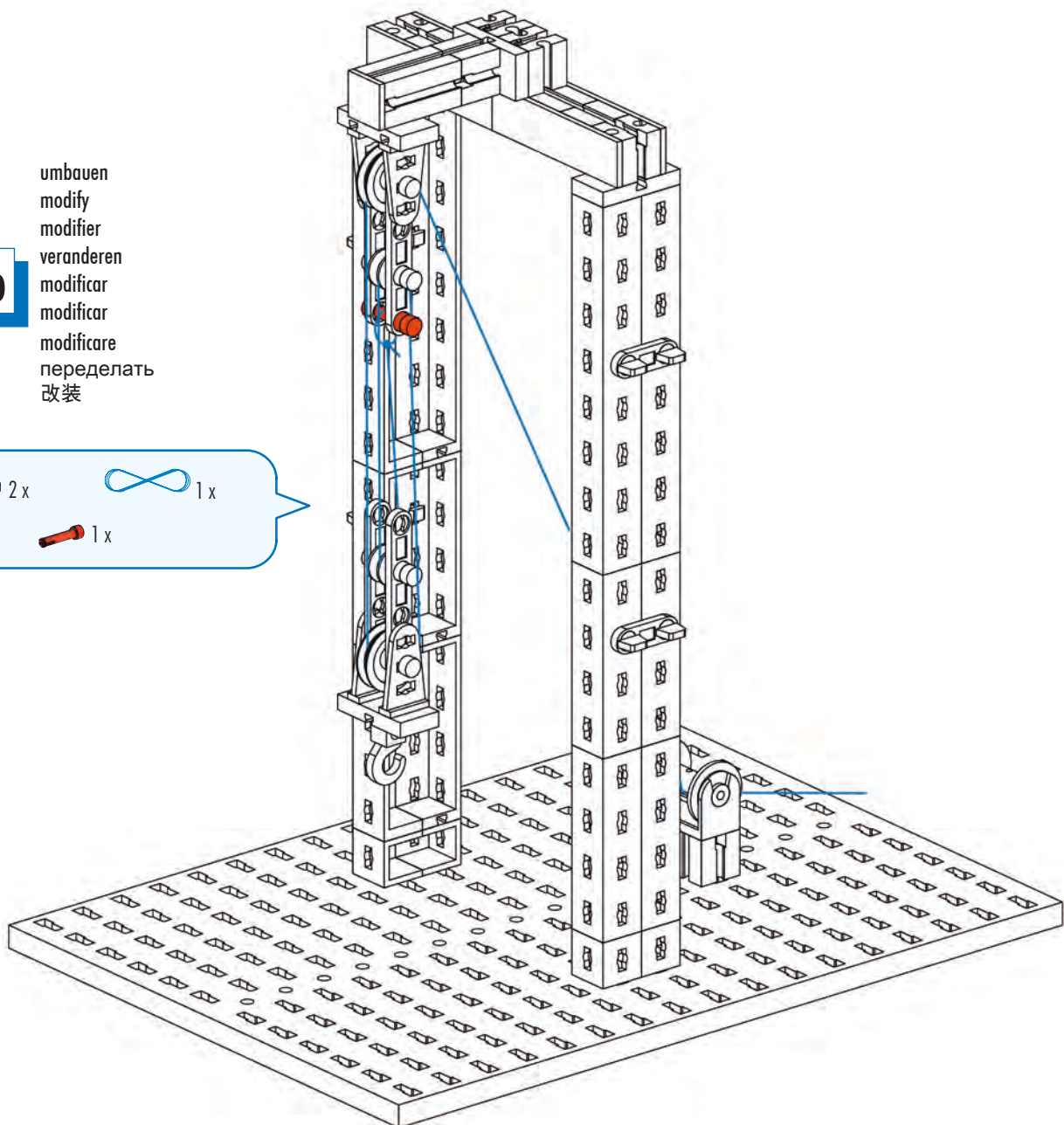

1 x



Motorisierung
Motor unit
Motorisation

Motorisering
Motorización
Motorização

Motorizzazione
Моторизация
机动化

10  1 x  1 x  1 x  5 x

 30 mm

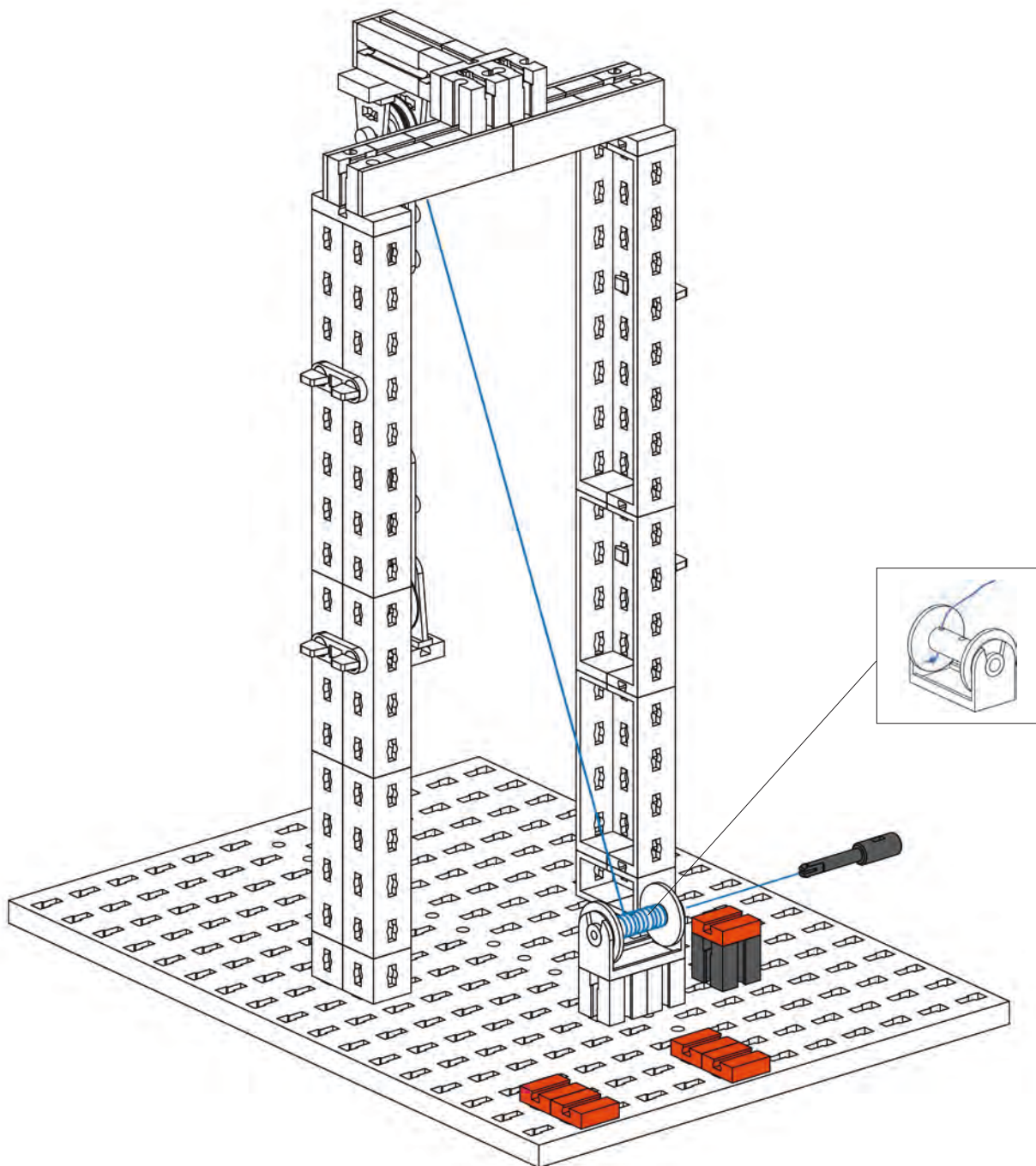

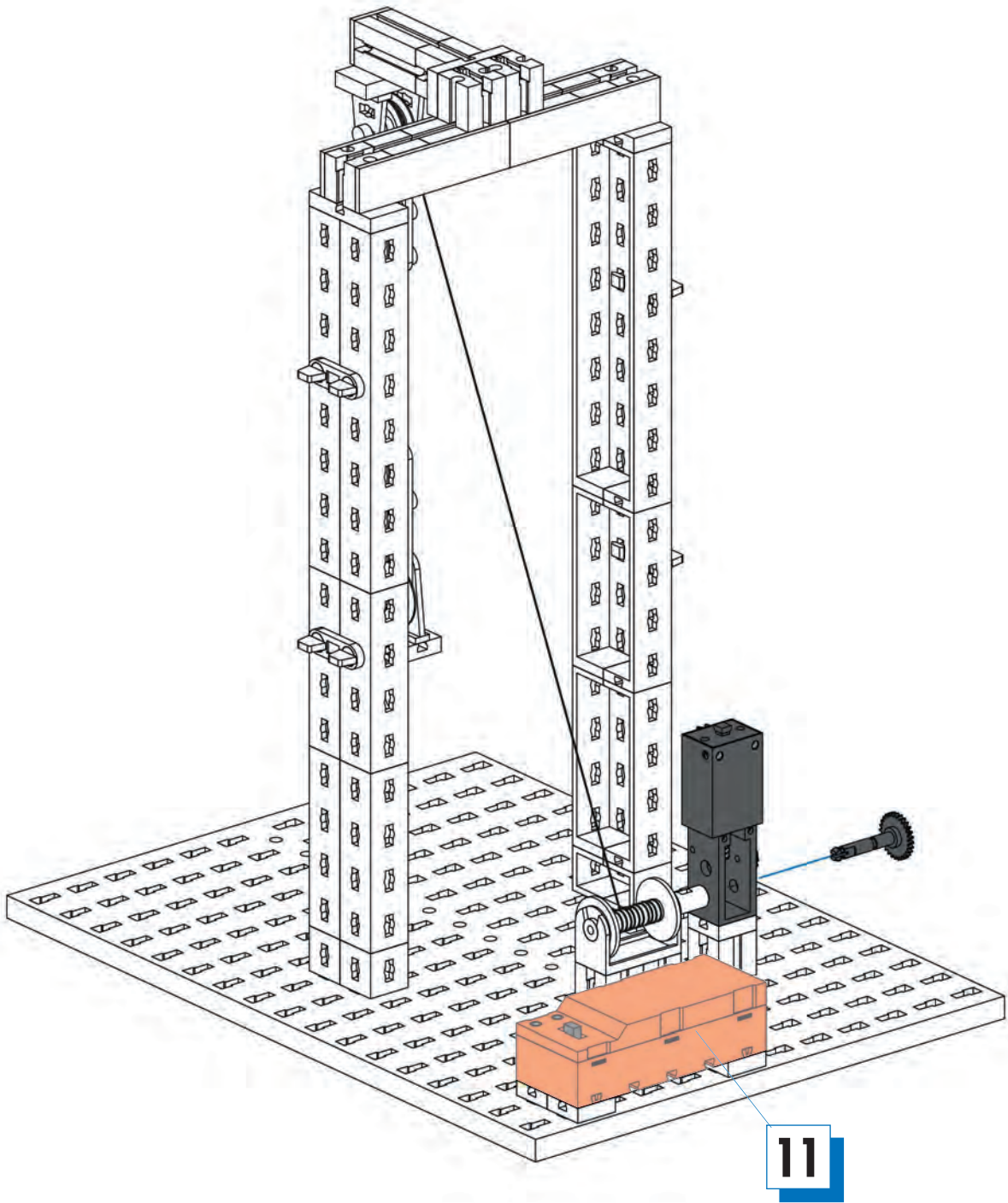
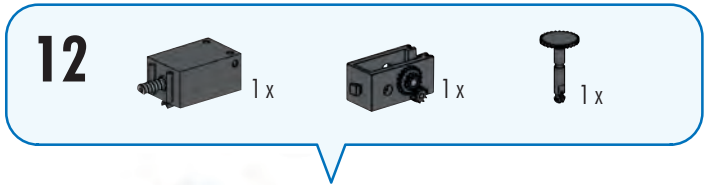
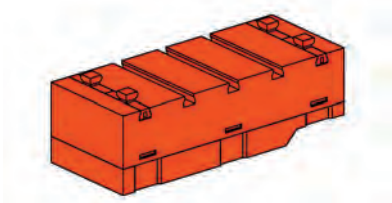
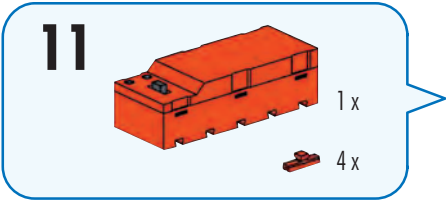

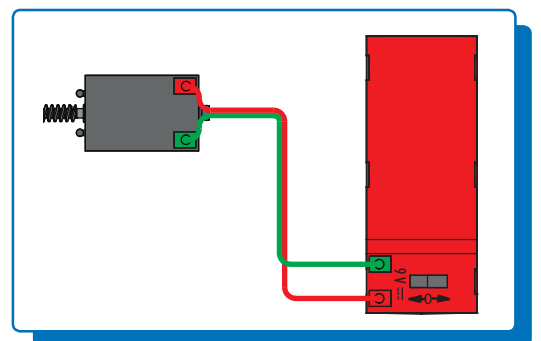
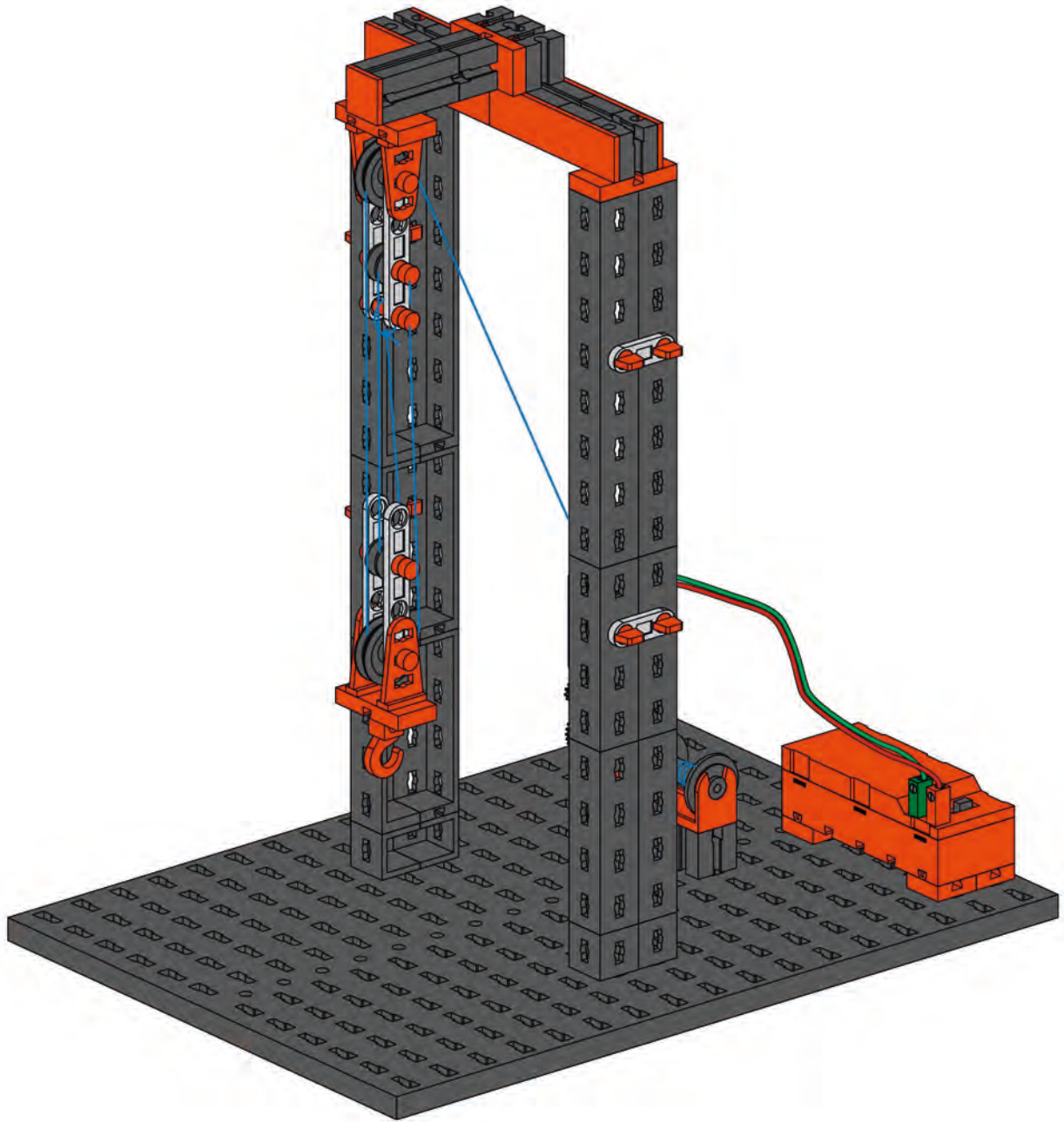

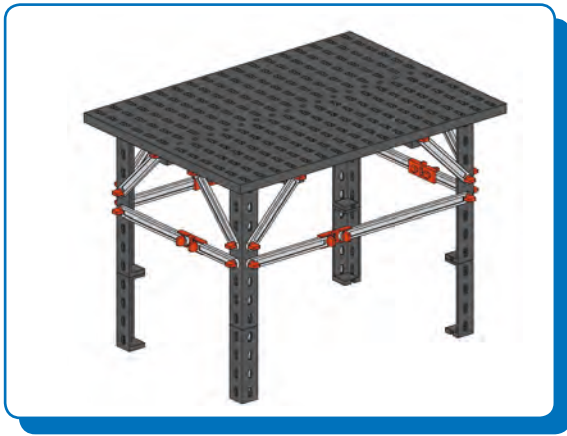

Tisch
Table
Table



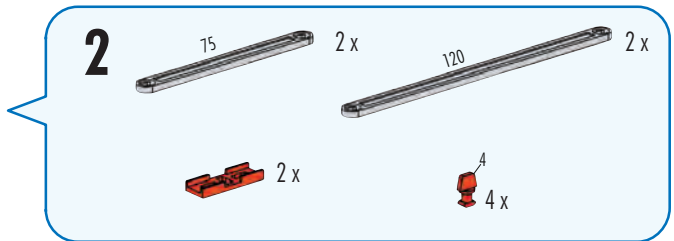
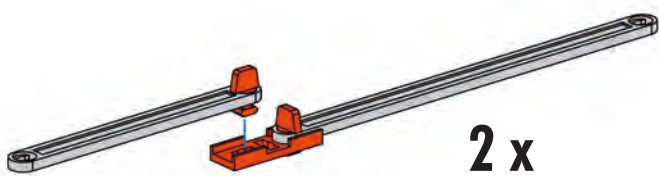
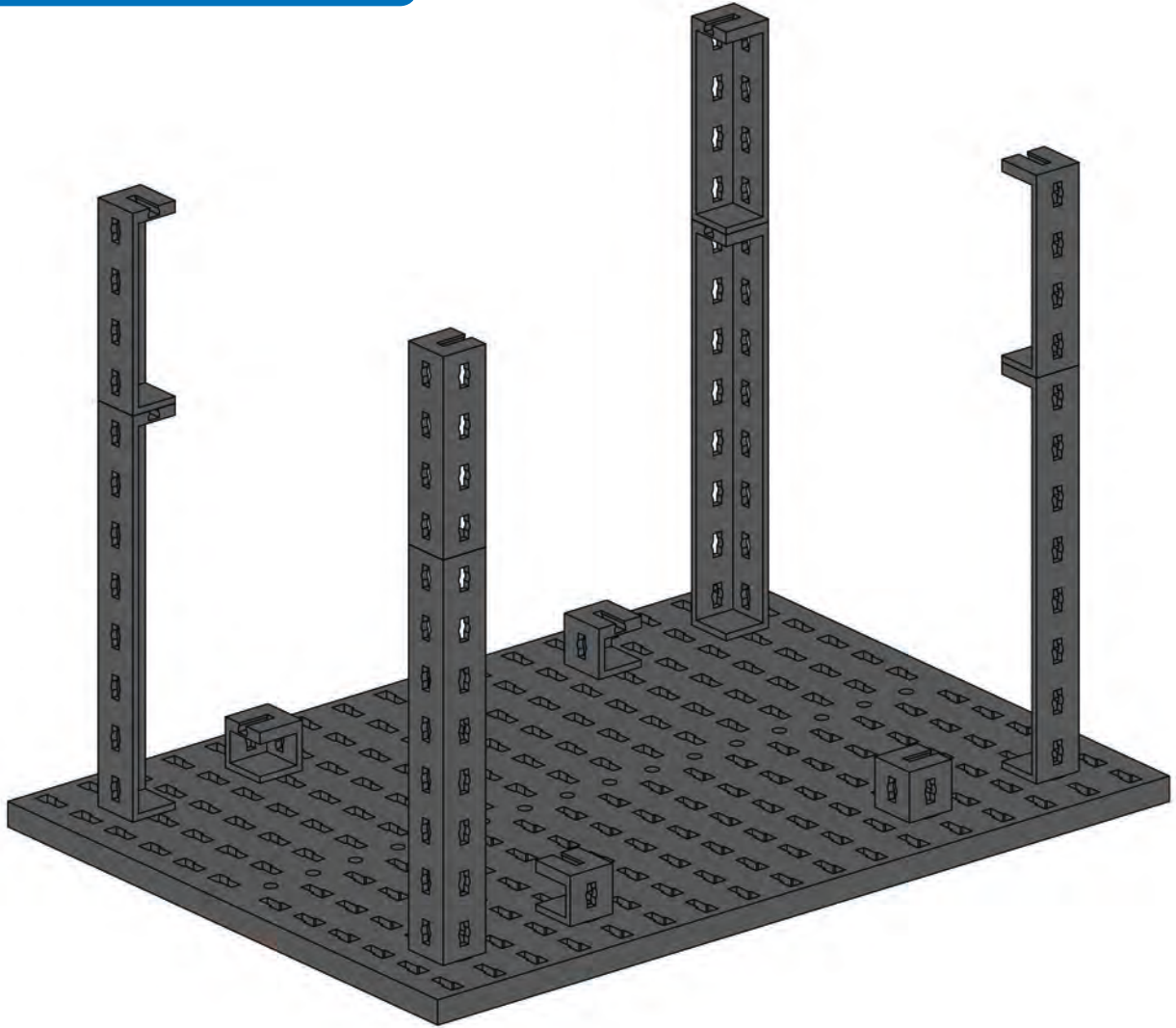
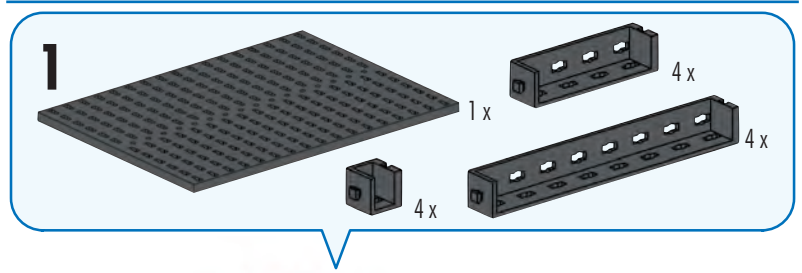

Tafel
Mesa
Mesa

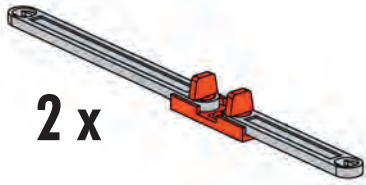
Tavola
Стол
工作







3

 75 2 x	 45 2 x
 2 x	 4 x

4

 4	 8 x	 4 x
---	---	---

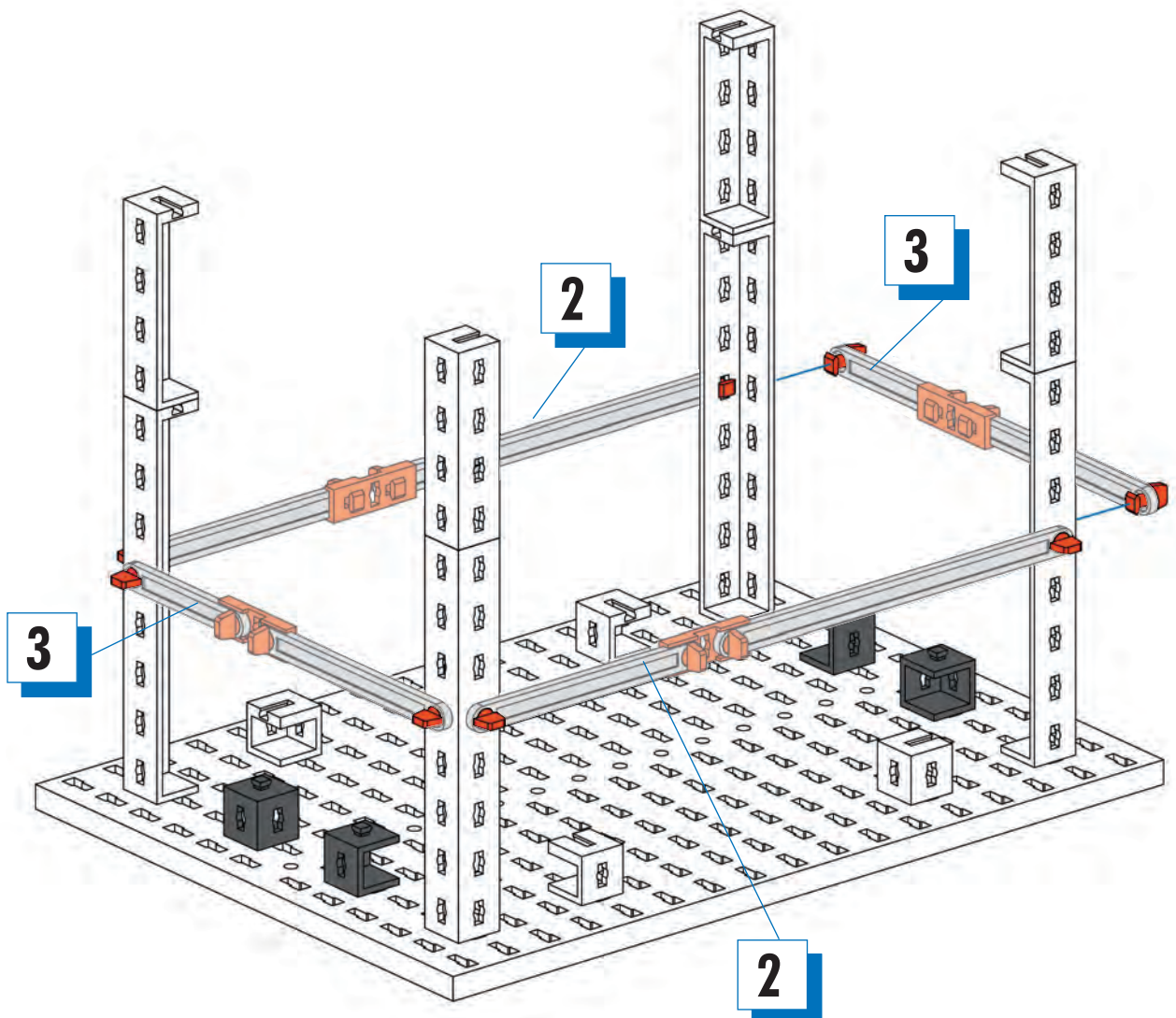

5

63,6 8 x

A 16 x

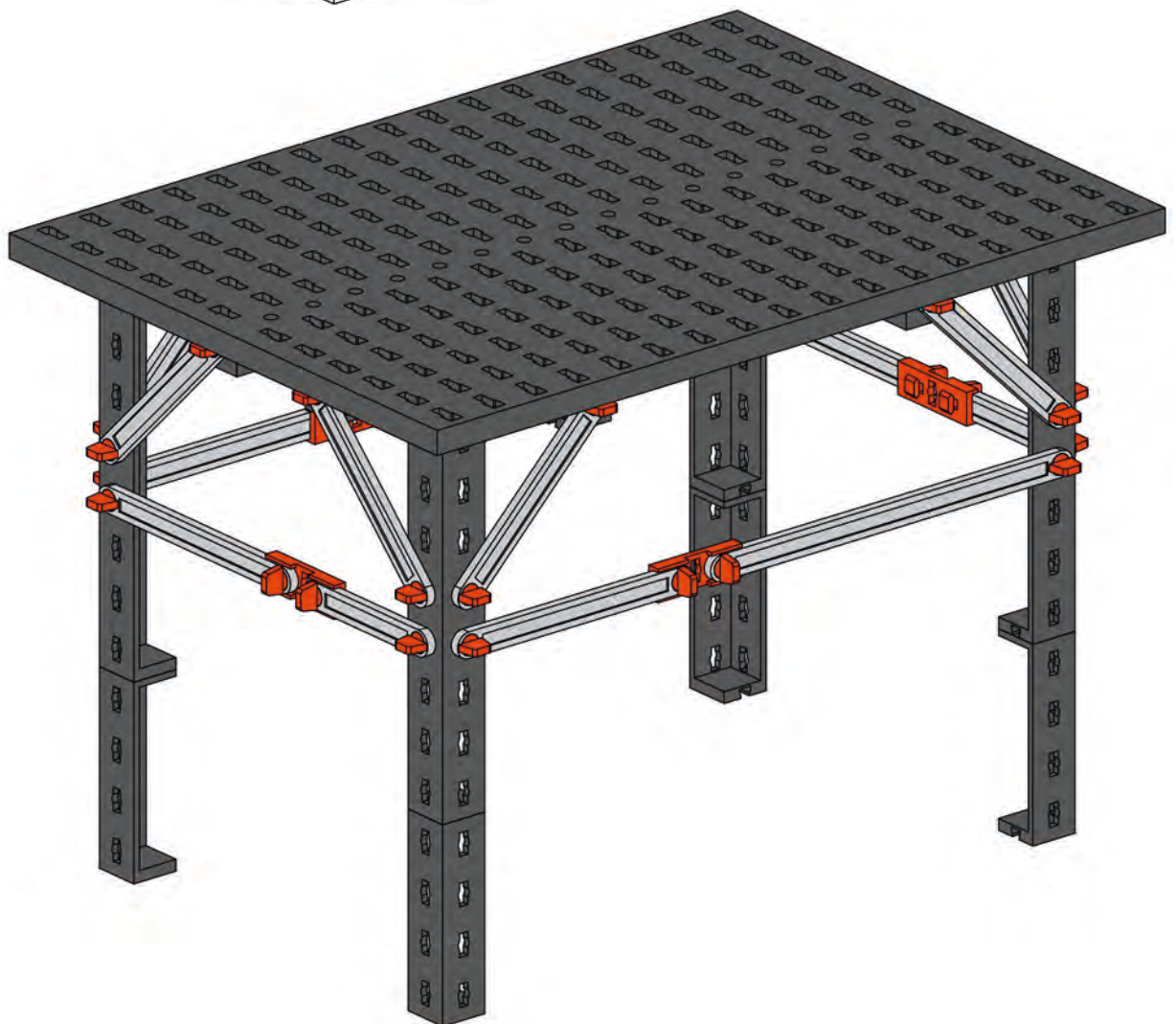
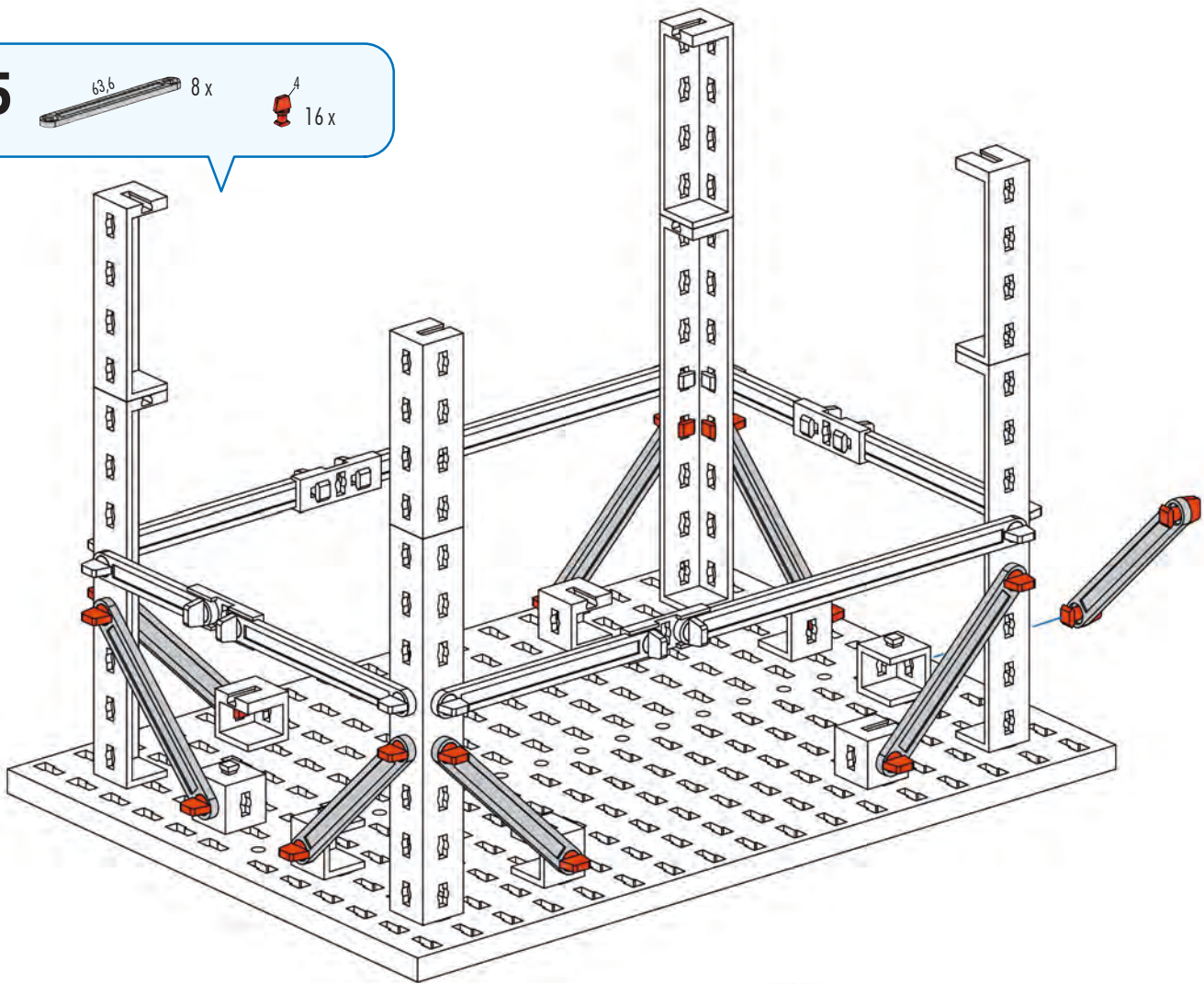



Bockleiter
Double ladder
Echelle double

Trapladder
Escalera de tijera
Escada de cavalete

Scala a libro
Стремянка
人字梯

1

2 x
 4 x
 8 x
 2 x
 1 x

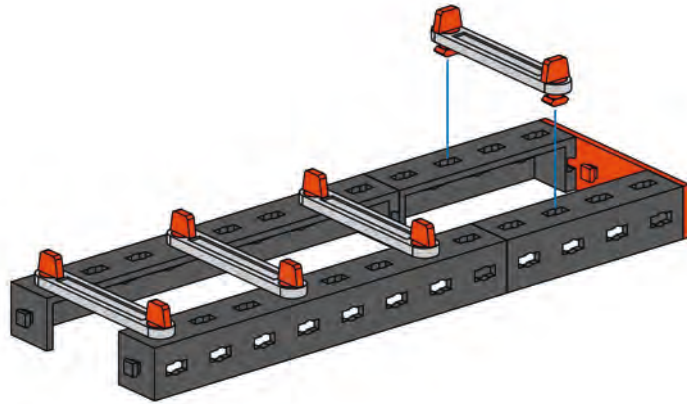

2

2 x
 2 x
 1 x
 2 x
 2 x

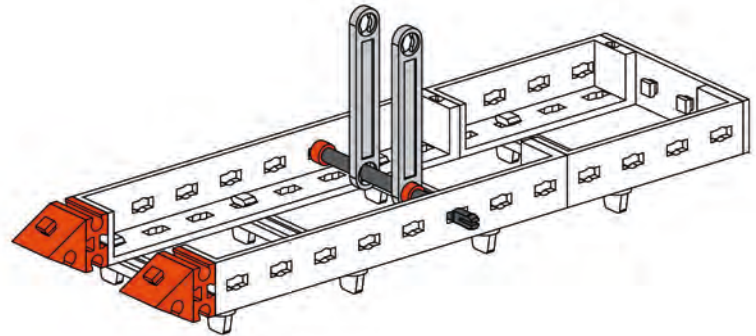
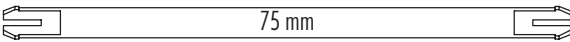

3

2 x
 2 x

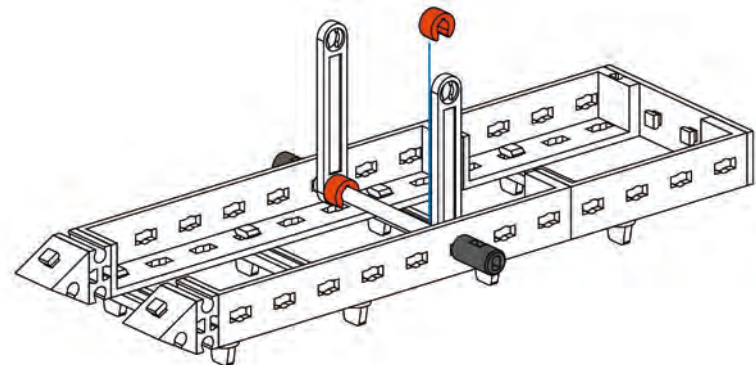

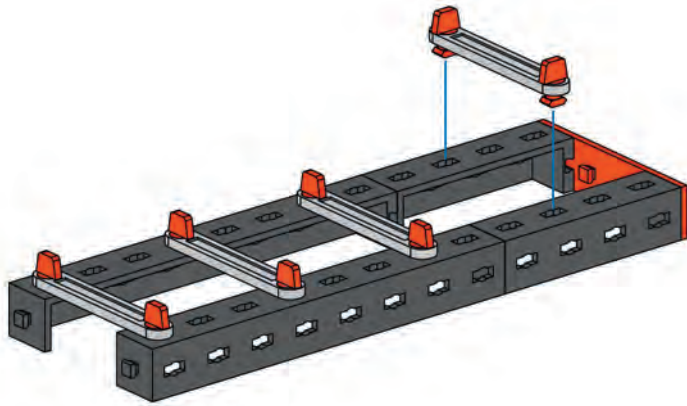

4

- 2 x [Grey Technic Beam 11-hole]
- 2 x [Grey Technic Beam 3-hole]
- 4 x [Grey Technic Pin 45]
- 8 x [Red Technic Pin 4]
- 1 x [Red Technic Beam 4-hole]

5

- 2 x [Grey Technic Pin 42.A]
- 2 x [Red Technic Pin 60°]
- 1 x [Grey Technic Pin 15]
- 2 x [Grey Technic Pin]
- 2 x [Red Technic Pin]

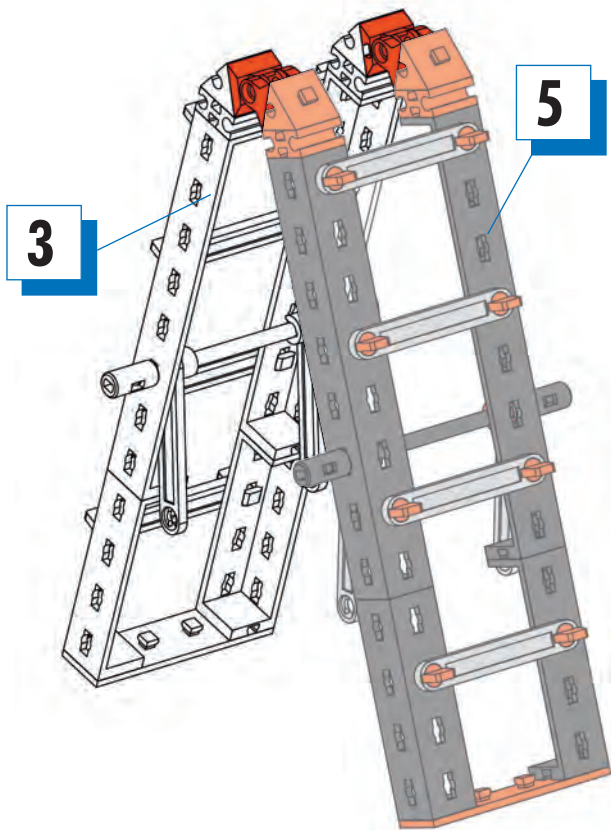
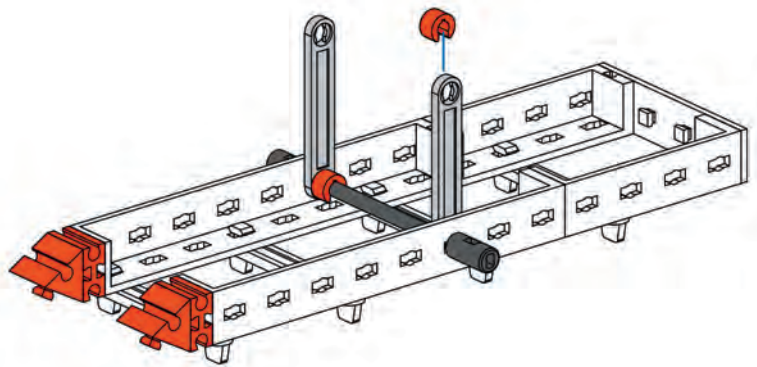
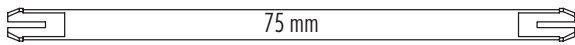

6

- 2 x [Red Technic Pin]

7

- 2 x [black pin]
- 2 x [red bush]
- 1 x [black axle, length 15]
- 2 x [red bush]

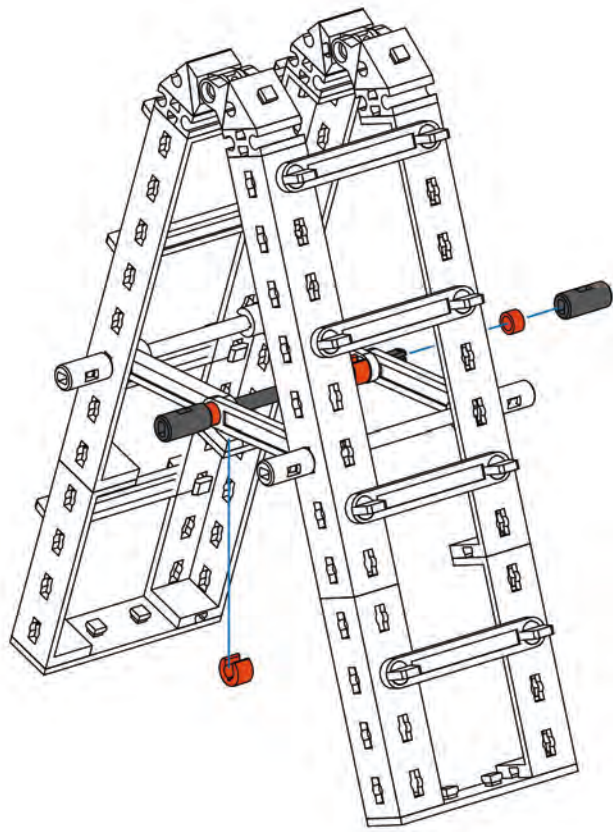
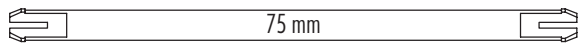

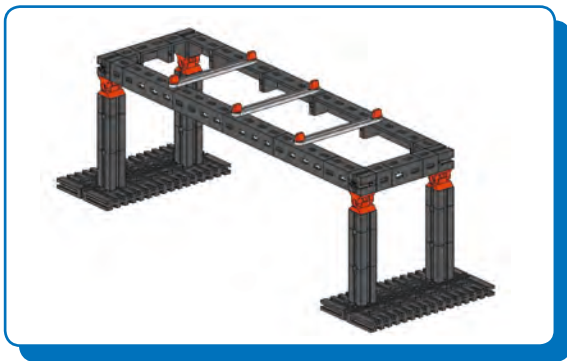

Balkenbrücke
Girder Bridge
Pont à poutres droites

Balkenbrug
Puente de vigas
Ponte de travessa

Ponte a trave
Балочный мост
梁式桥

1

2x 8x 4x 4x

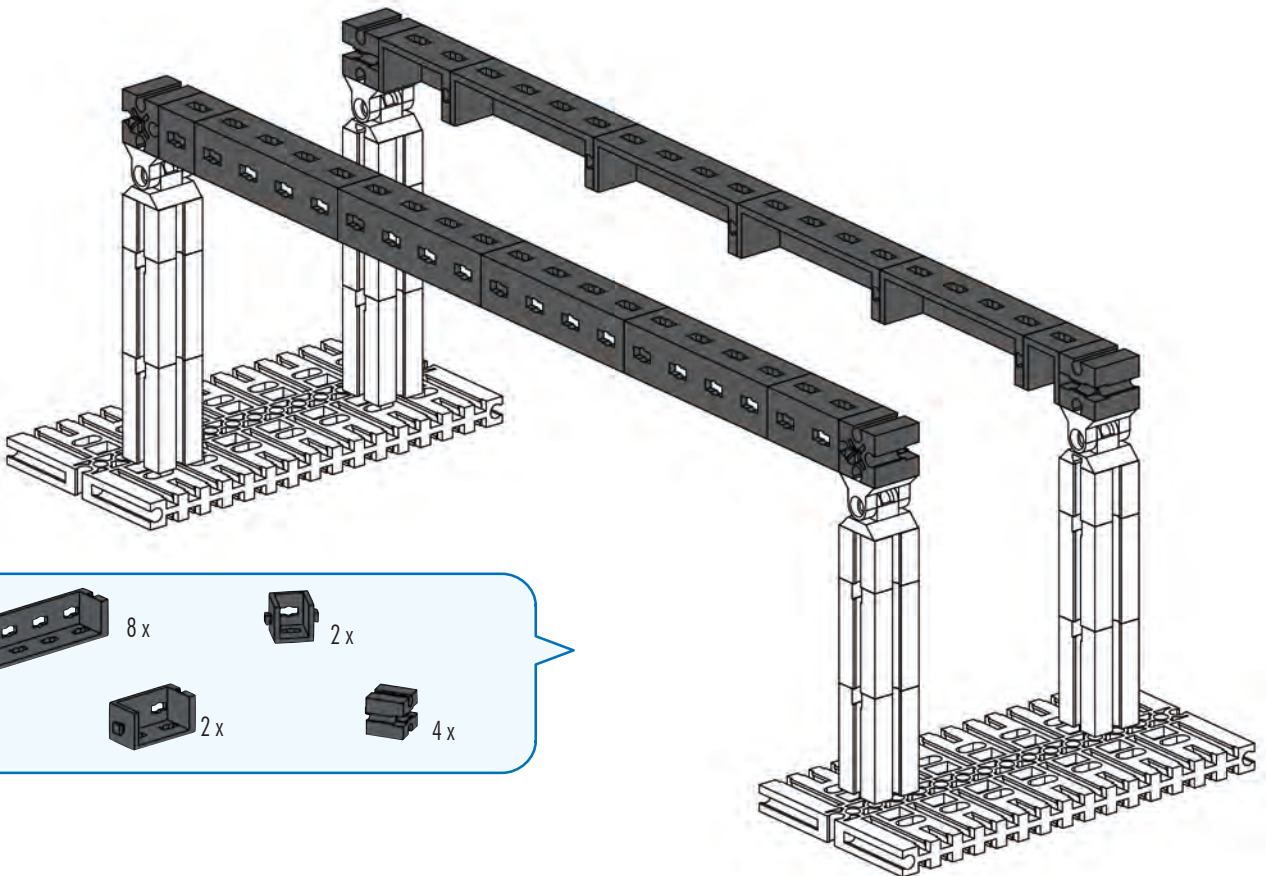
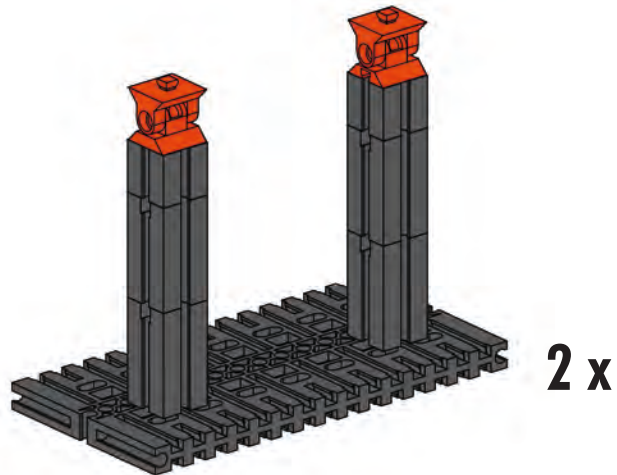



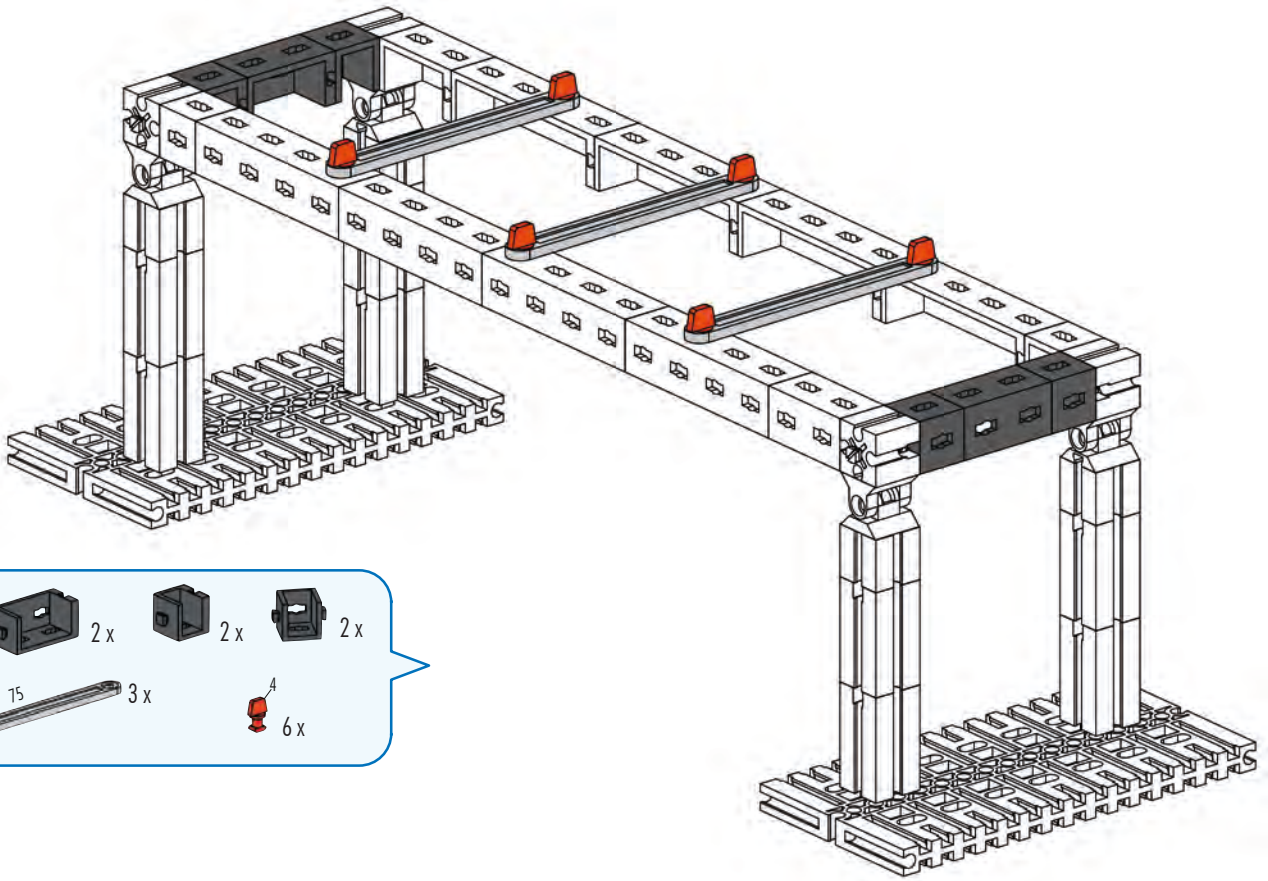

2

8x 2x 2x 4x



3

-  2x
-  2x
-  2x
-  15 3x
-  4 6x

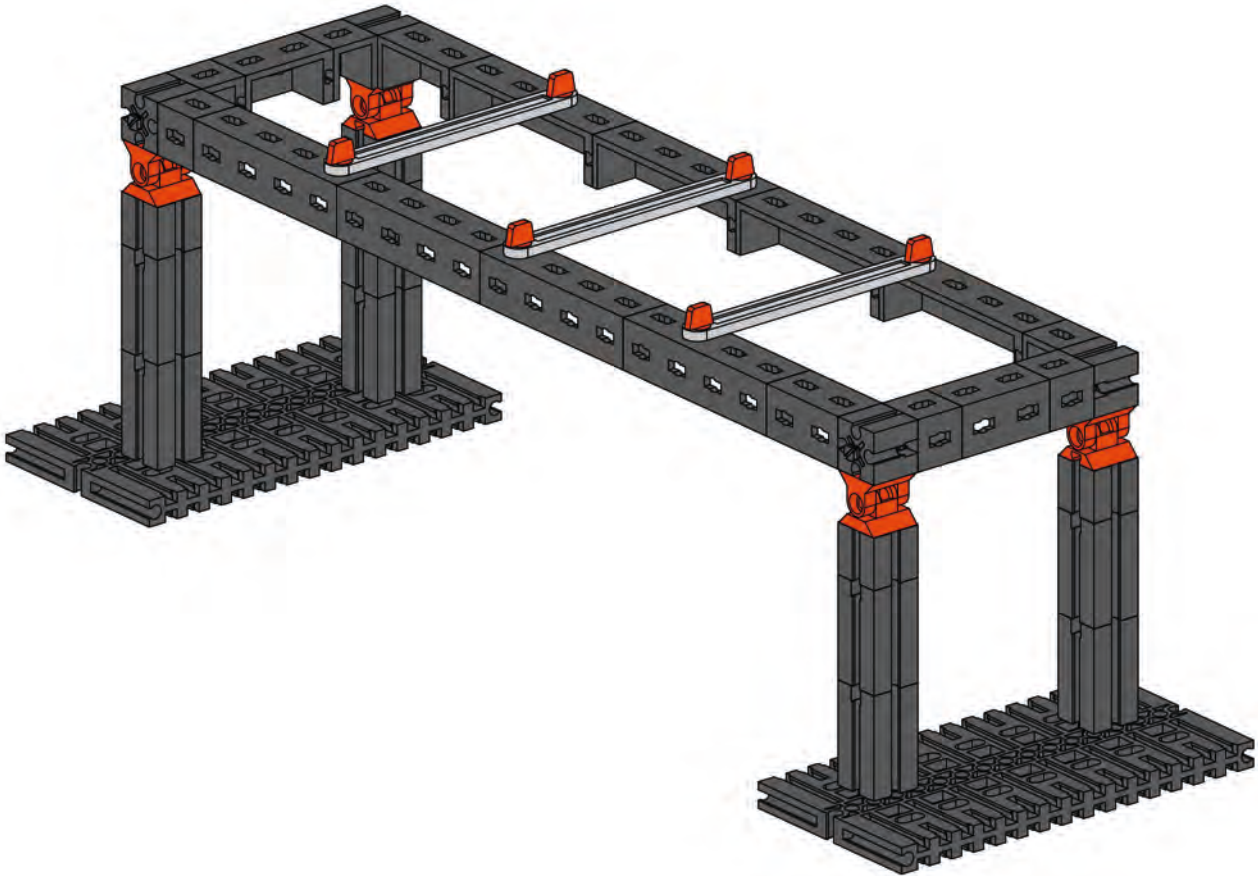

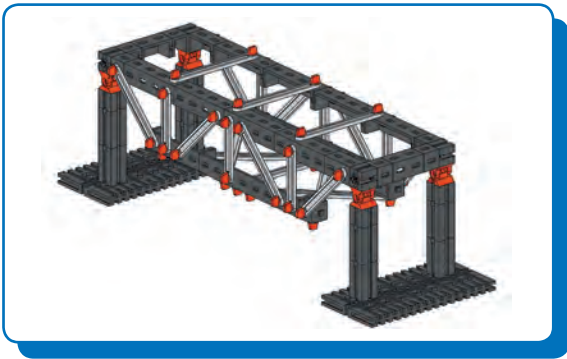

Brücke mit Unterzug
 Bridge with Underbeam
 Pont avec
 solive transversale

Brug met onderslagbalken
 Puente con viga maestra
 Ponte com viga de sustentação
 inferior

Ponte con trave inferiore
 Мост с нижней рамой
 带下托梁的桥

1-3

Seite 93
 Page 93
 Page 93
 Bladzijde 93
 Página 93
 Pagina 93
 Pagina 93
 Страница 93
 页次 93

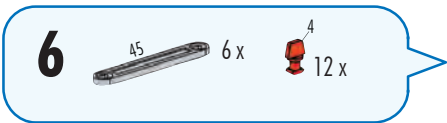
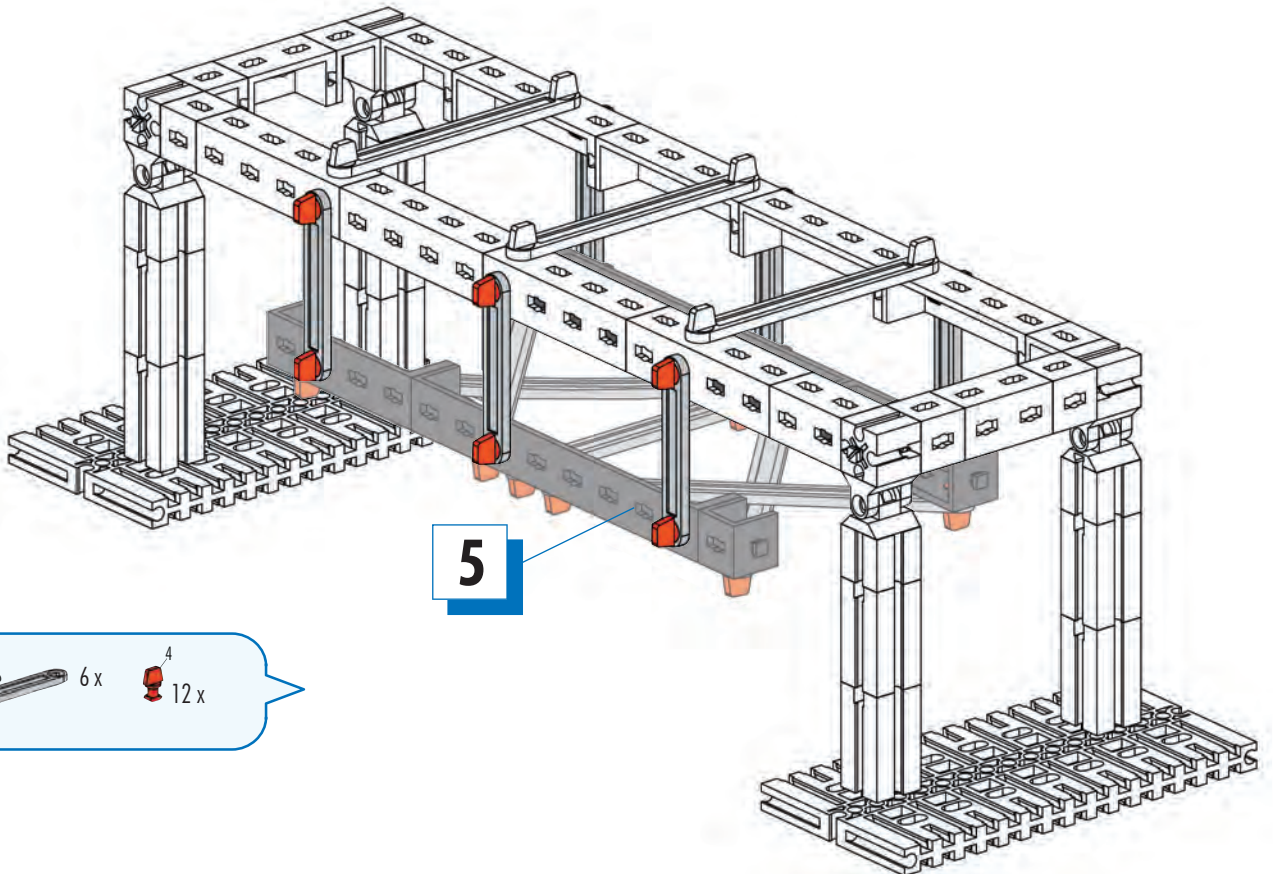
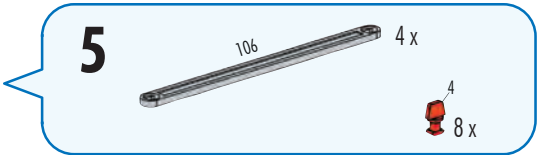
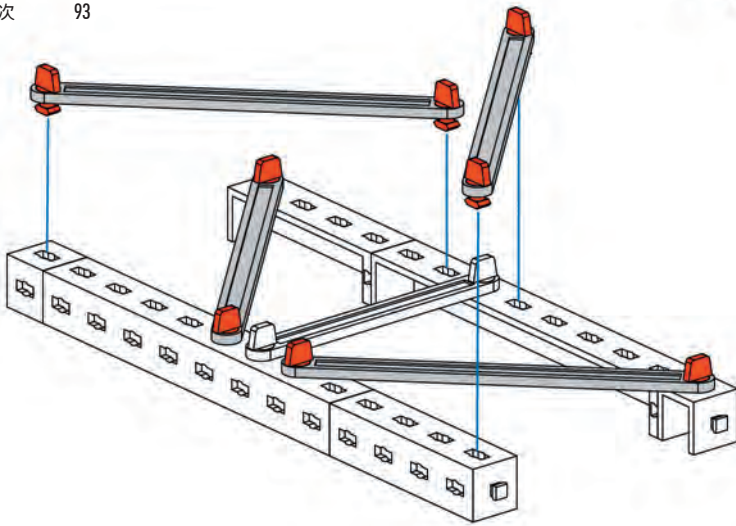
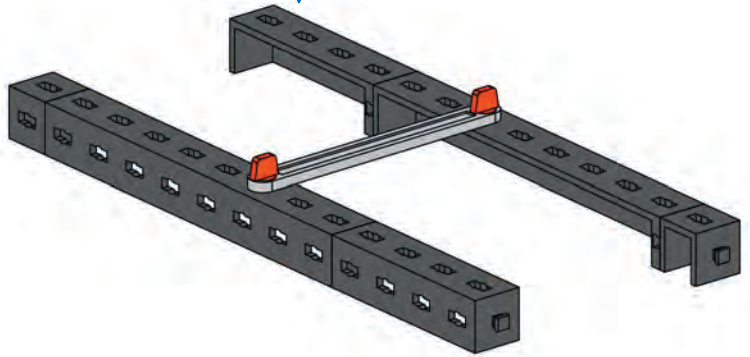
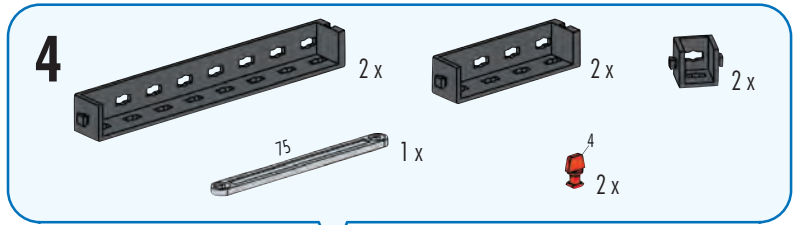

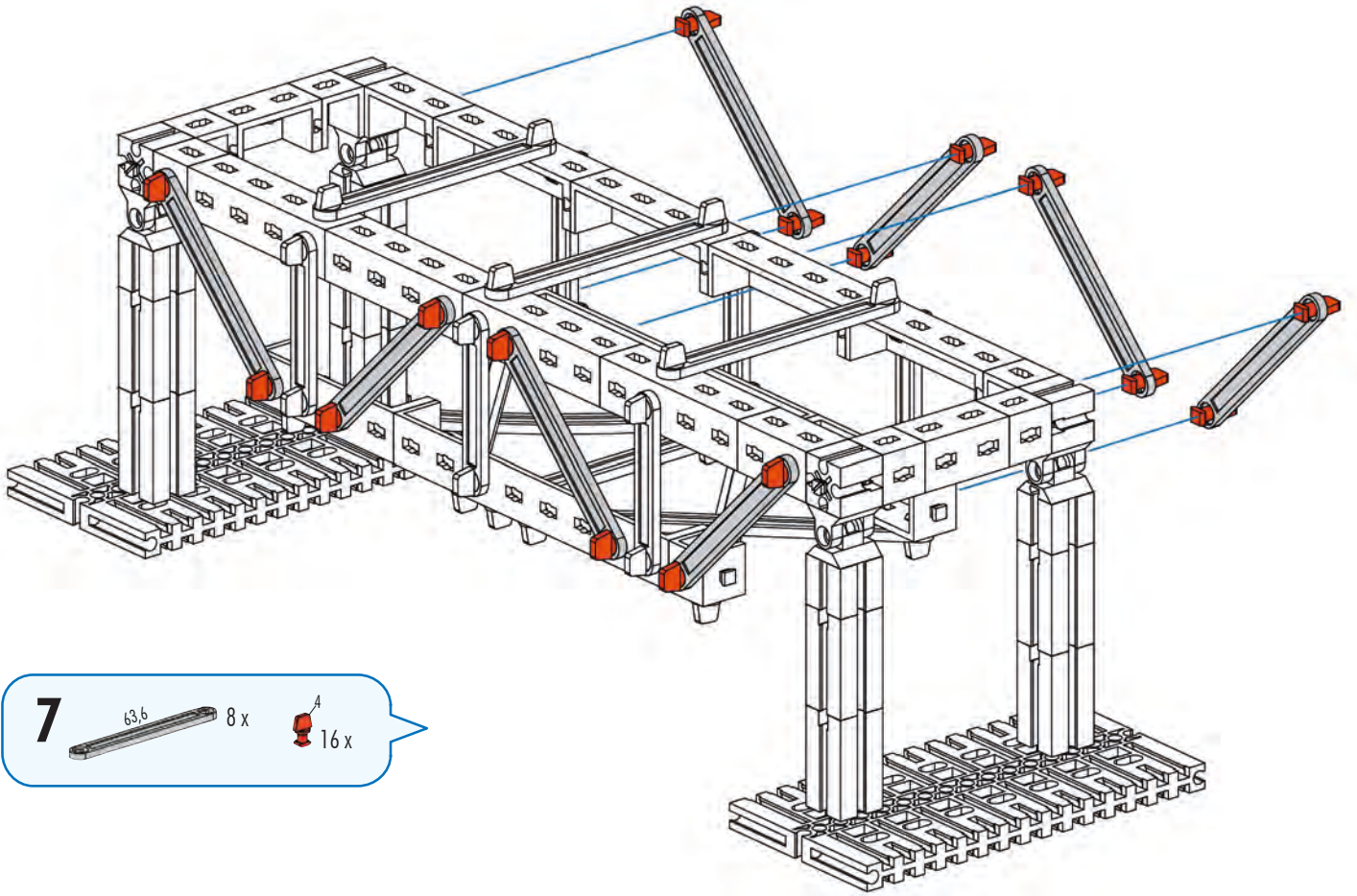

7 63,6 8 x  16 x

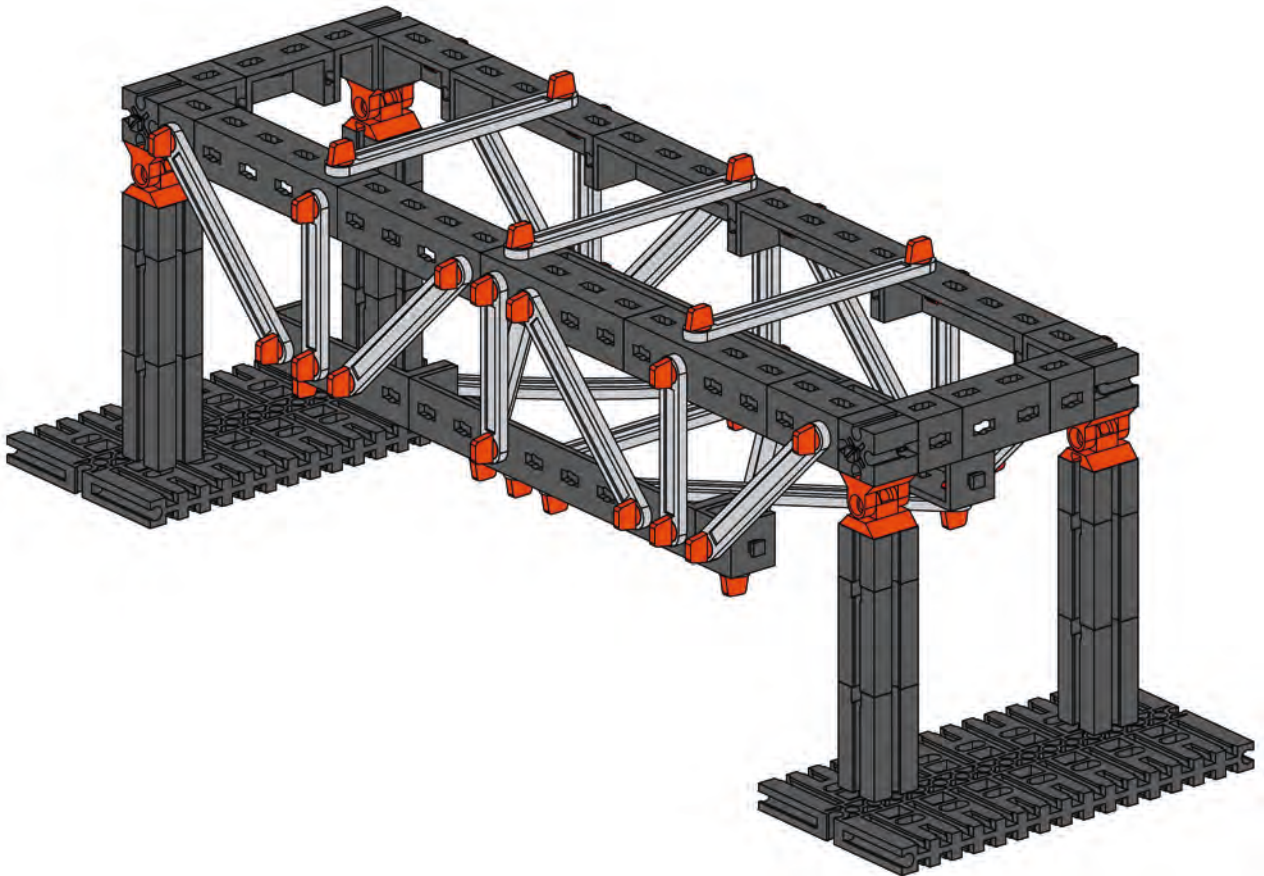



Brücke mit Oberzug **Brug met bovenslagbalken** **Ponte con trave superiore**
Bridge with Upperbeam **Puente con viga testera** **Мост с верхней рамой**
Pont à membrure **Ponte com viga de** **带上托梁的桥**
supérieure transversale **sustentação superior**

1

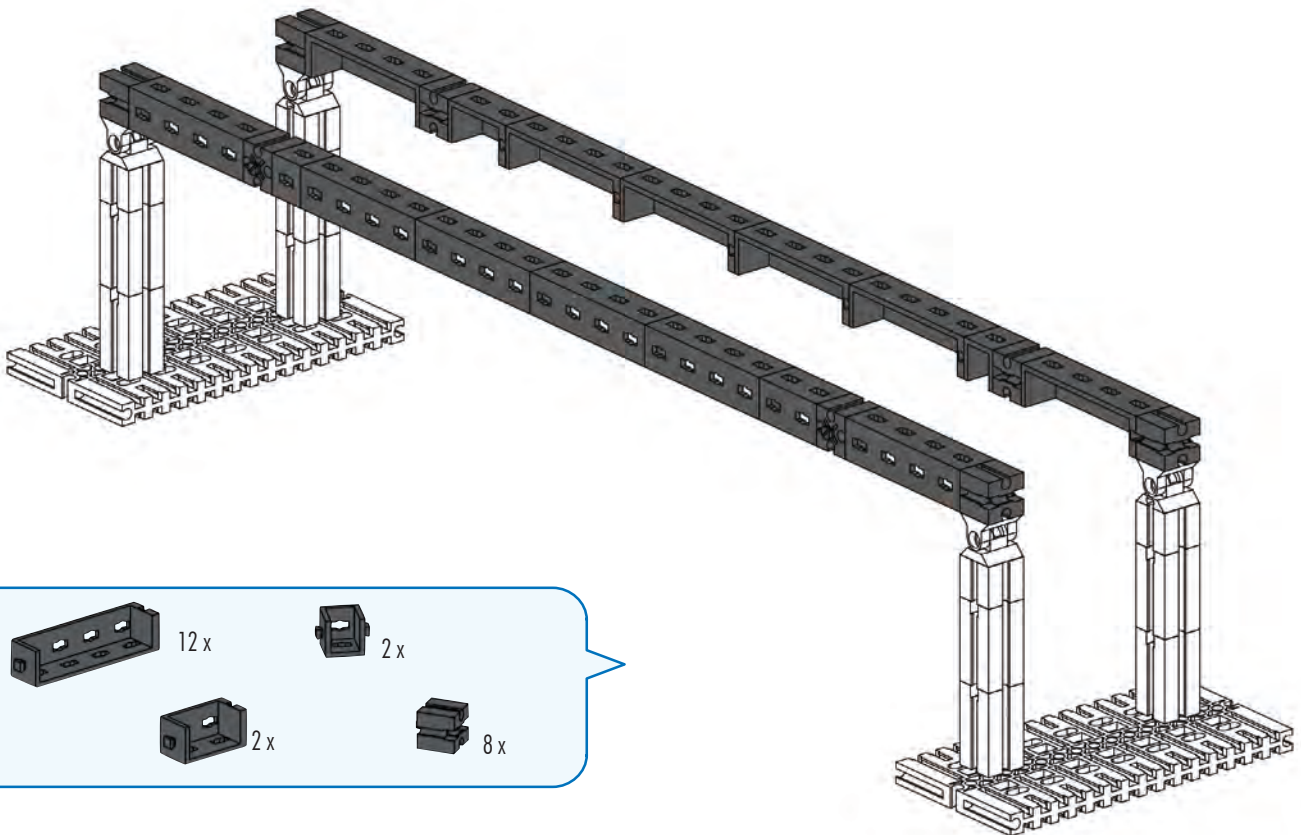
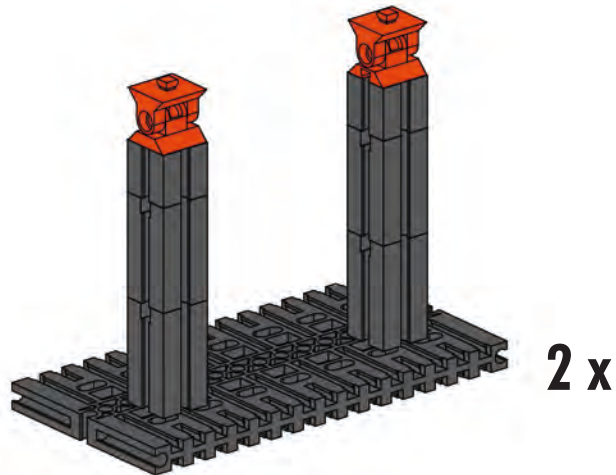

2

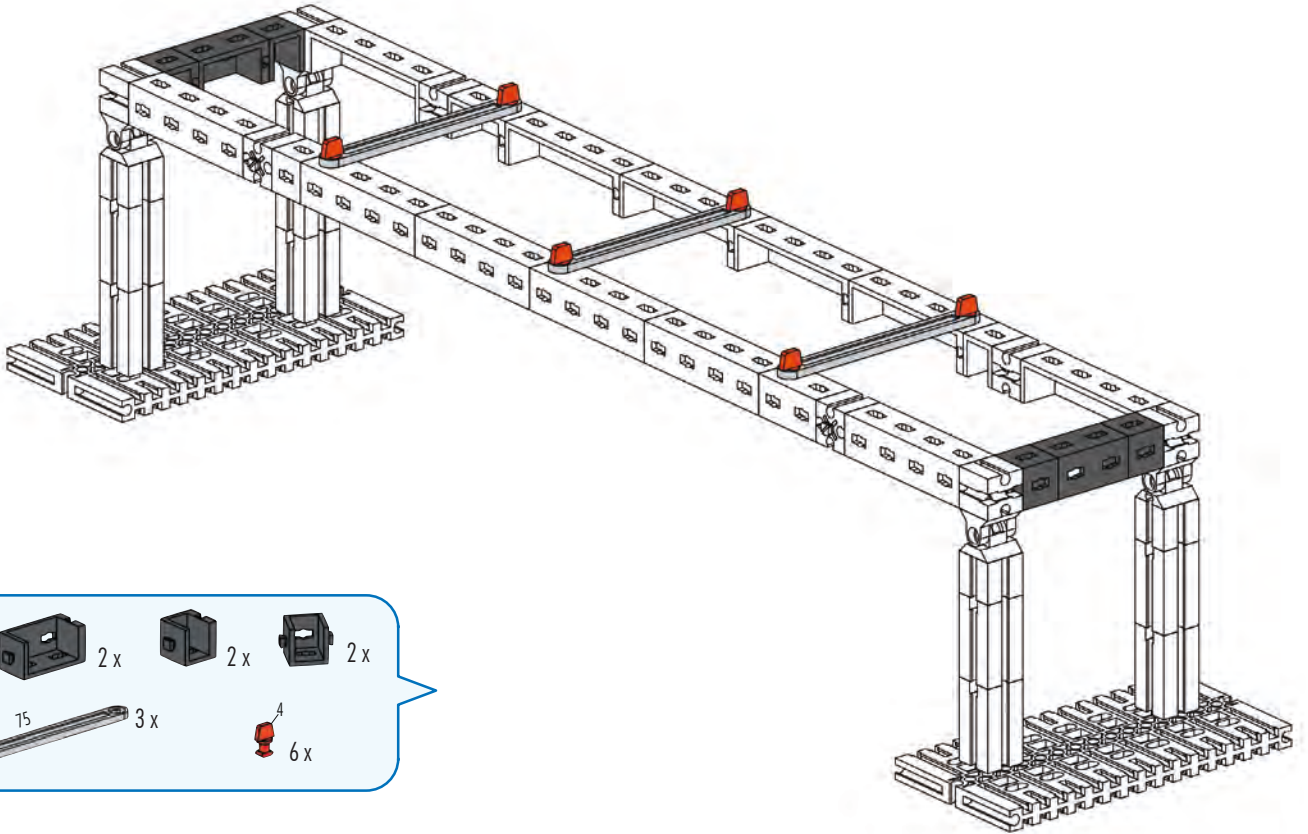

3

- 2 x [Small black connector]
- 2 x [Small black connector]
- 2 x [Small black connector]
- 3 x [Long grey axle, labeled 15]
- 6 x [Red bush, labeled A]

4

- 4 x [Long black beam]
- 3 x [Long grey axle, labeled 15]
- 2 x [Small black connector]
- 2 x [Small black connector]
- 6 x [Red bush, labeled A]

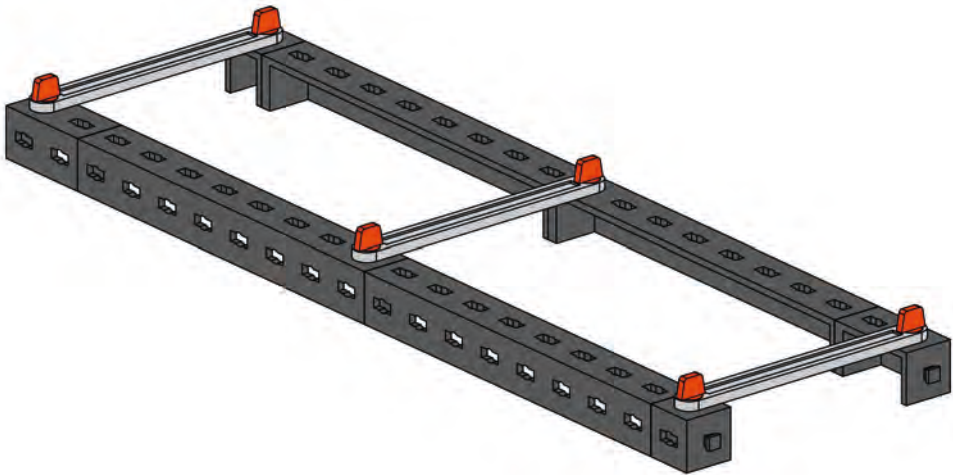

5 106 4 x
 4 8 x

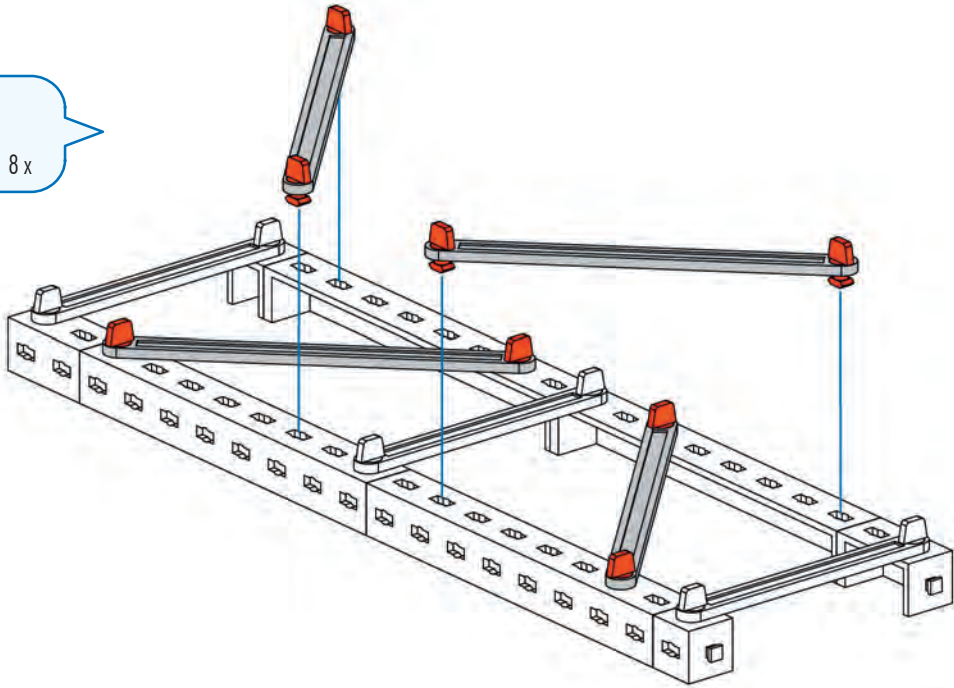

5

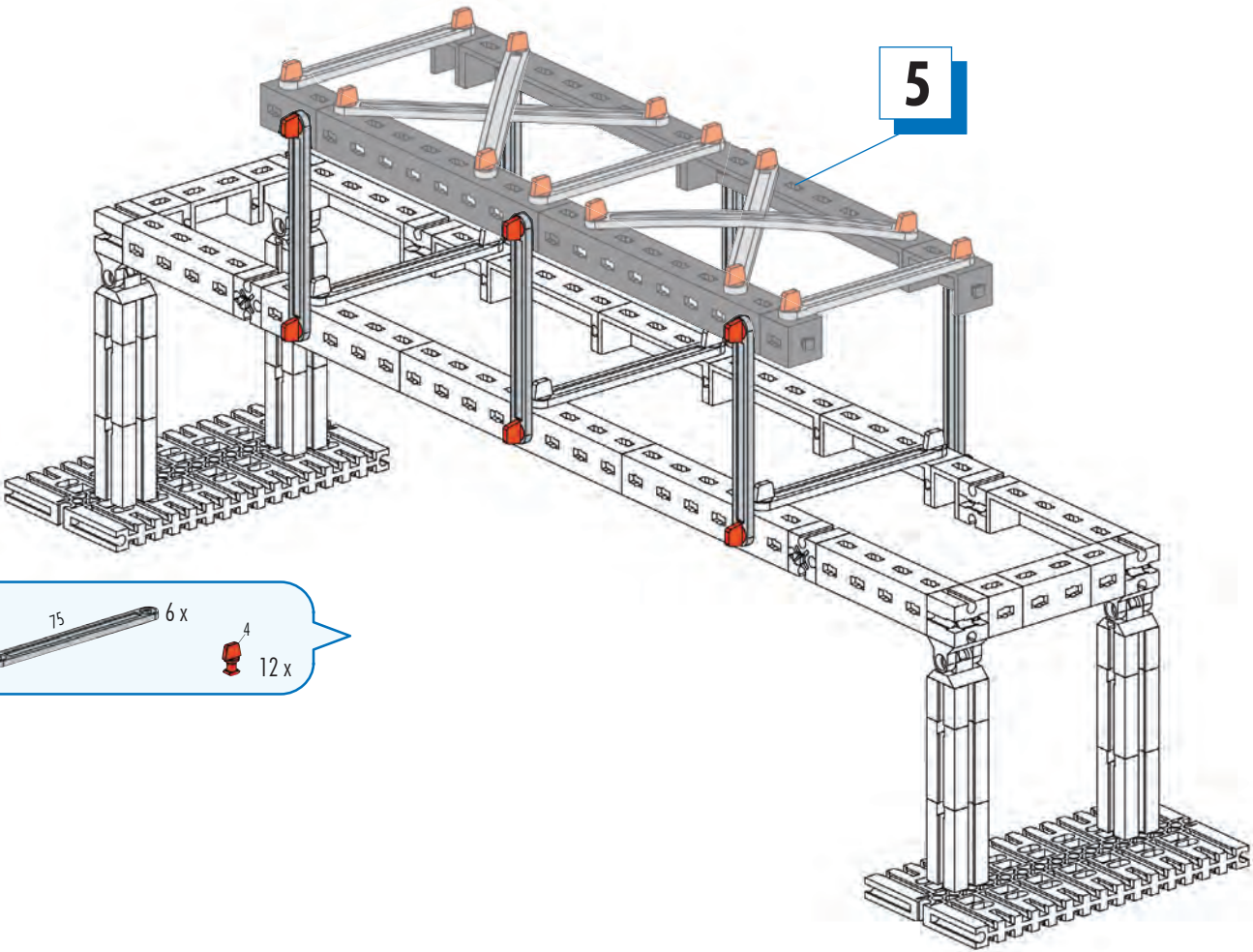

6 15 6 x
 4 12 x

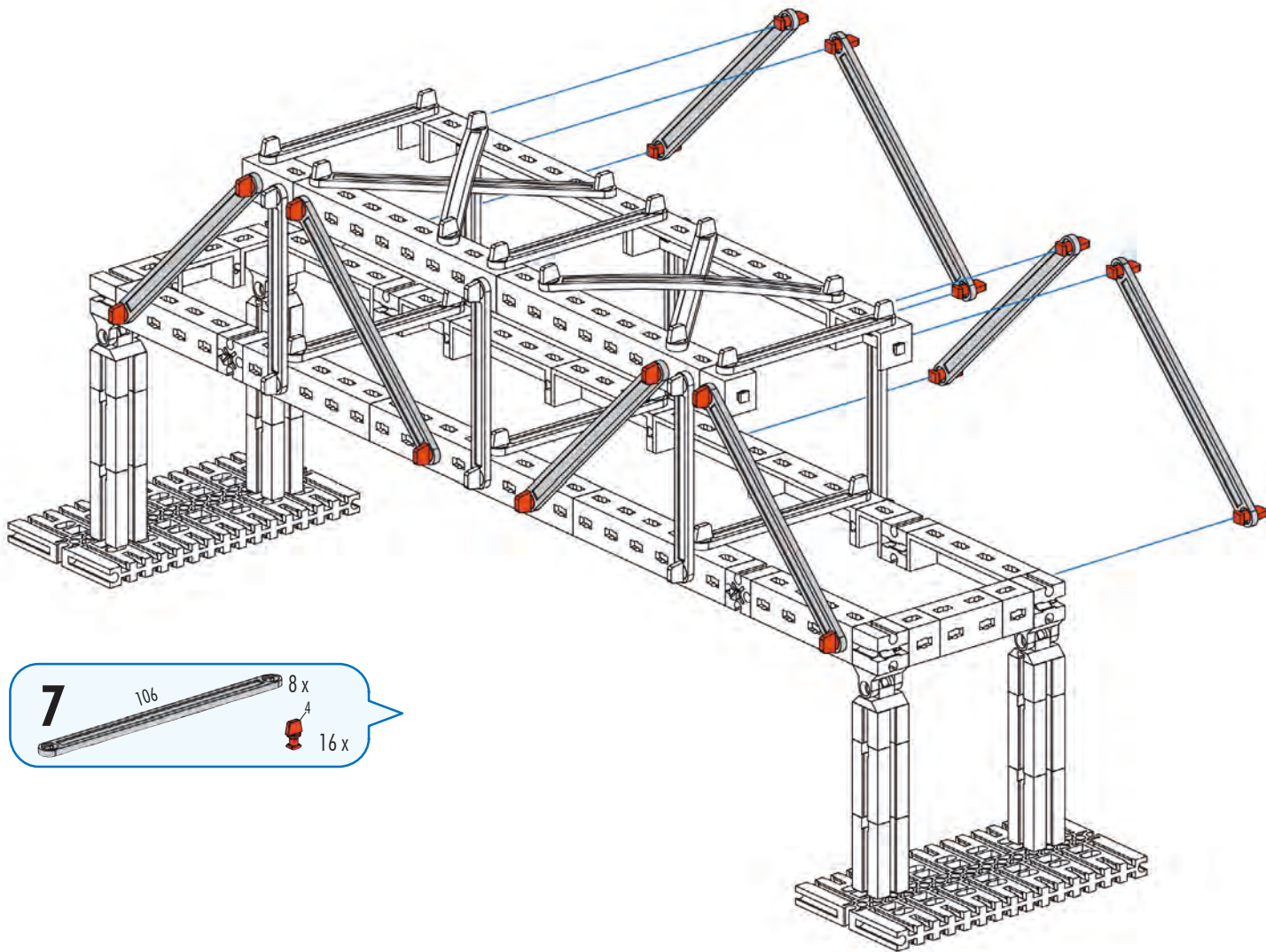

7 106 8 x
A 16 x





Schrägseilbrücke
Cable-stayed bridge
Pont à haubans

Tuibrug
Puente atirantado
Ponte estaiada

Ponte con funi di sospensione
Вантовый мост
斜拉桥

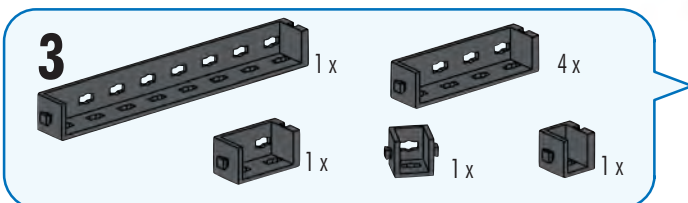
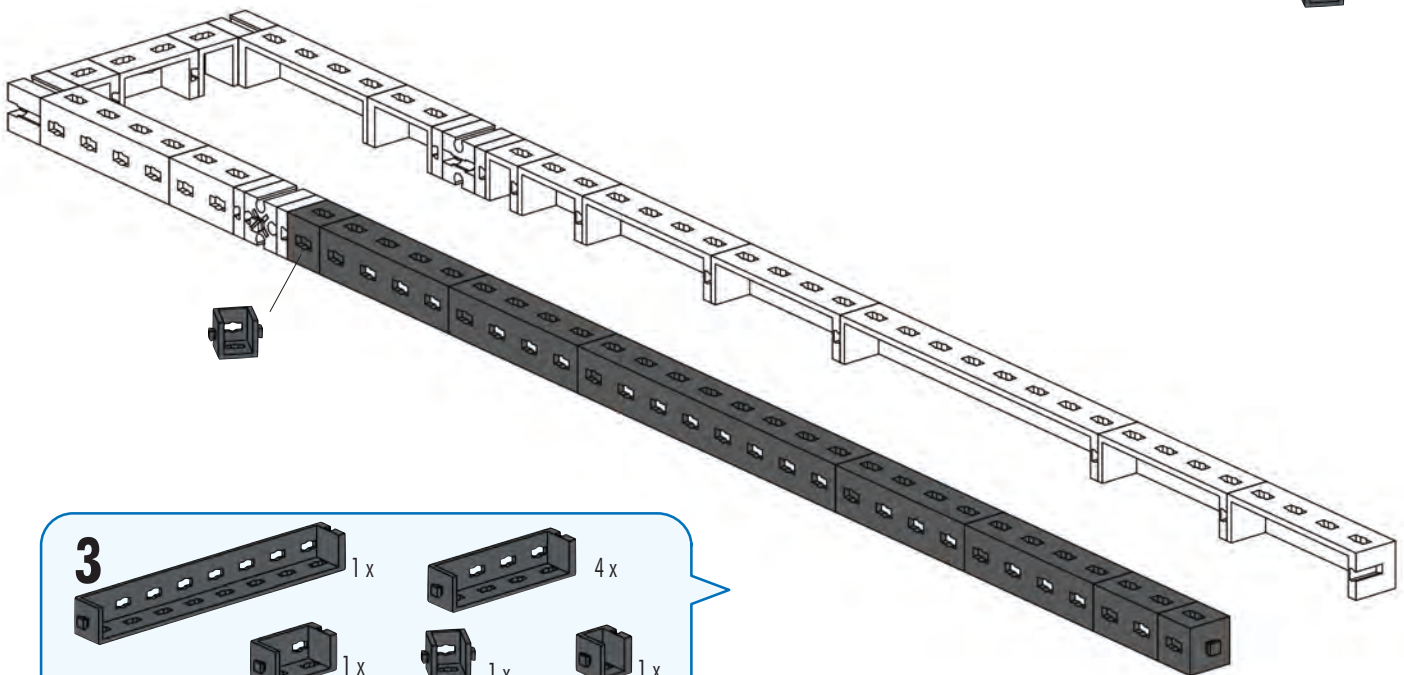
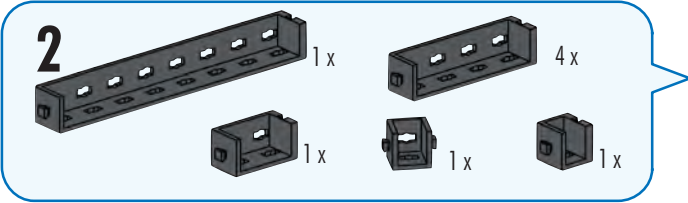
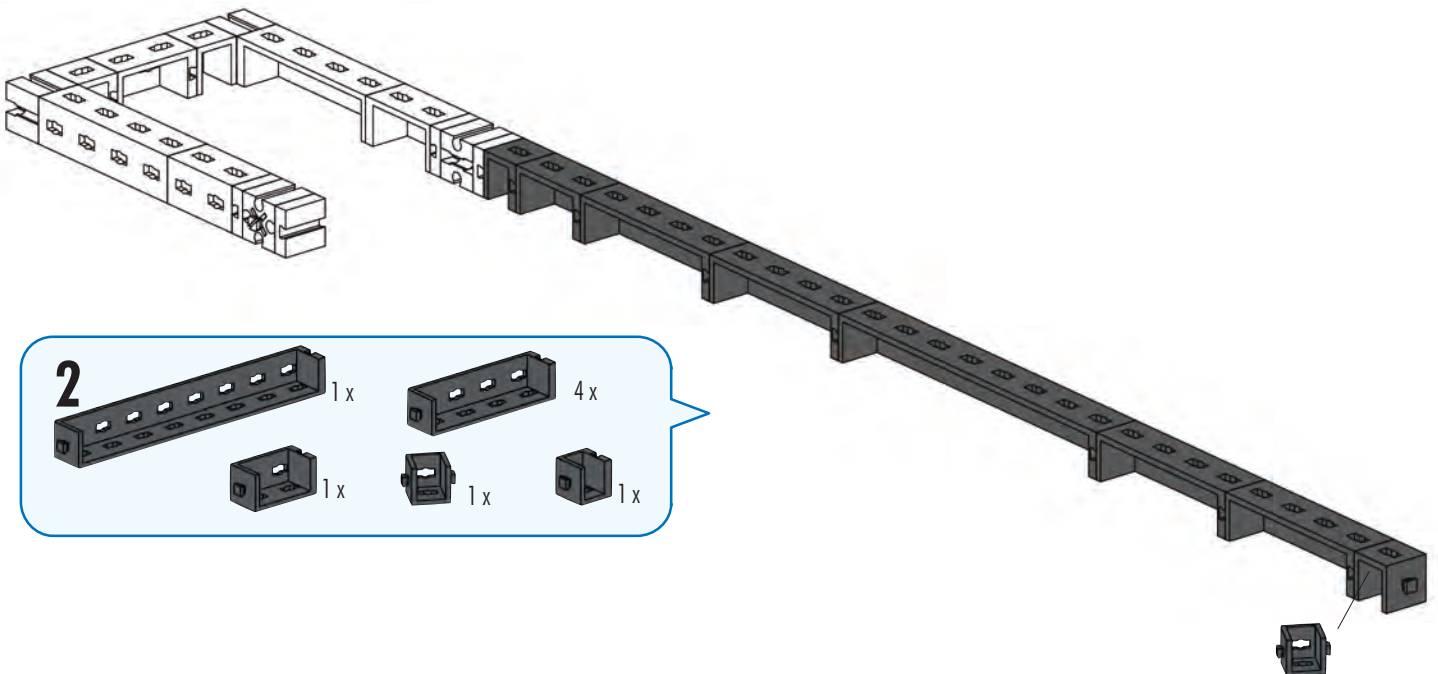
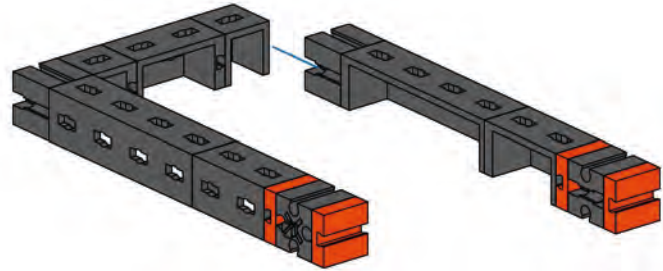
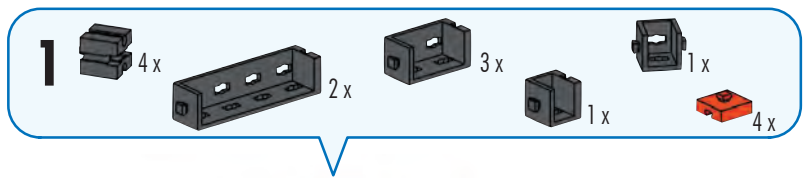

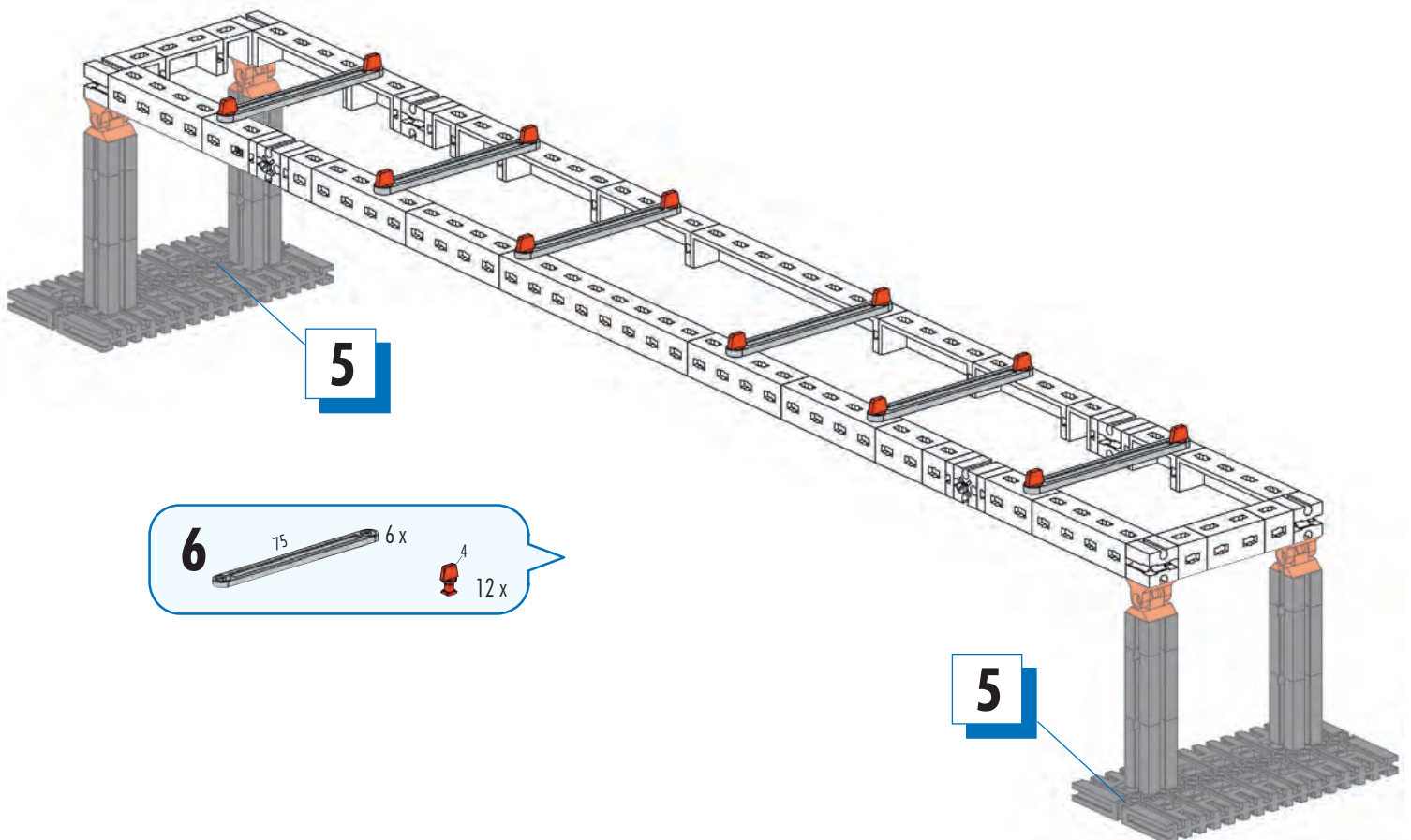
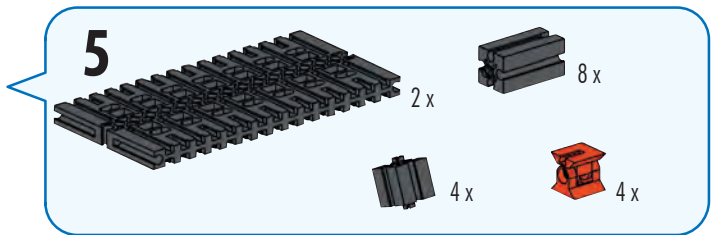
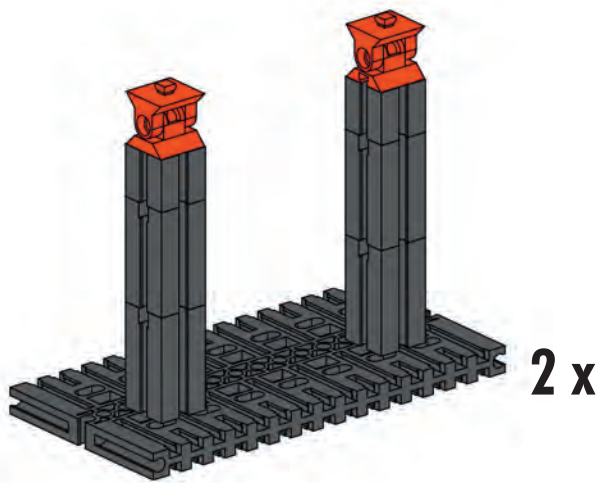
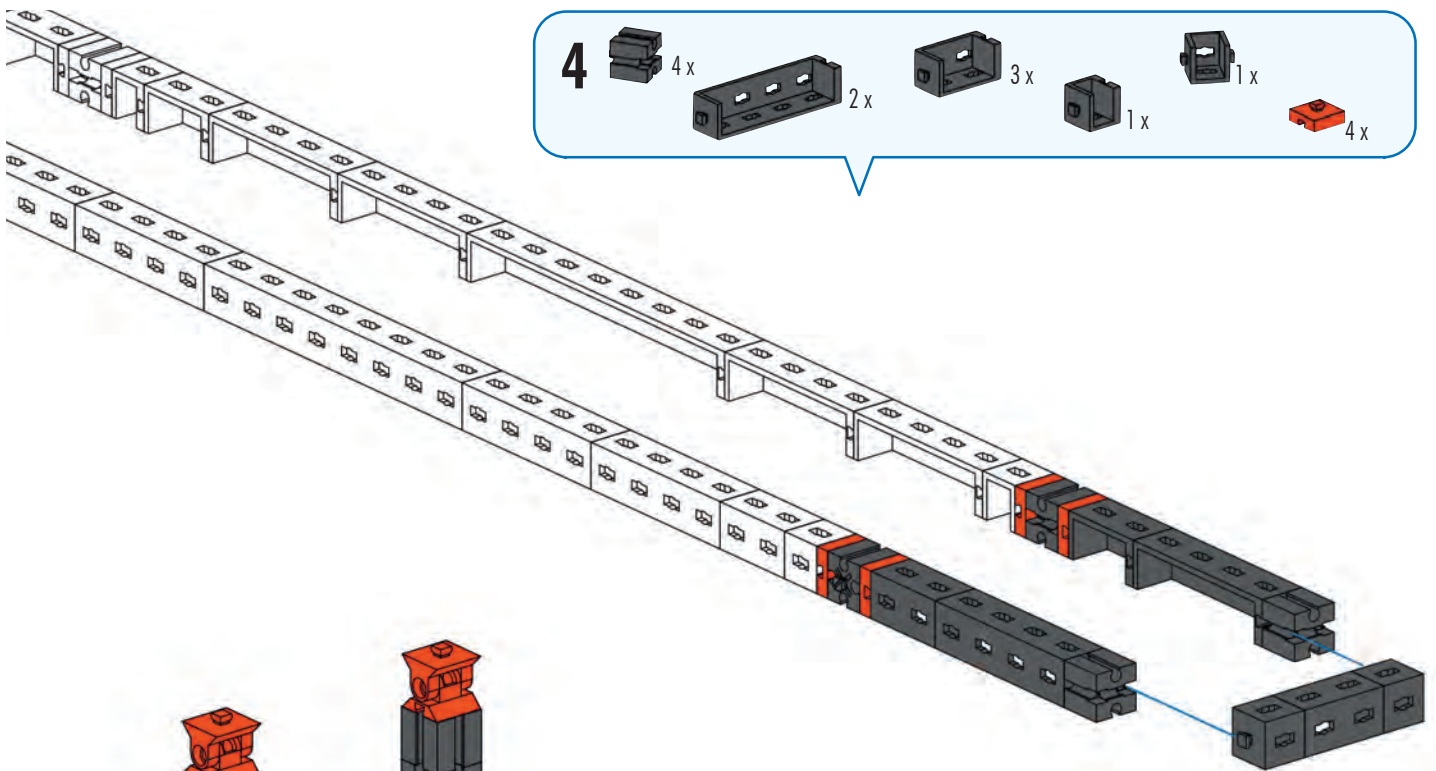

7

- 2 x (long orange Technic beam)
- 5 x (black Technic axle)
- 1 x (red Technic bush)
- 2 x (red Technic bush)
- 1 x (red Technic bush)

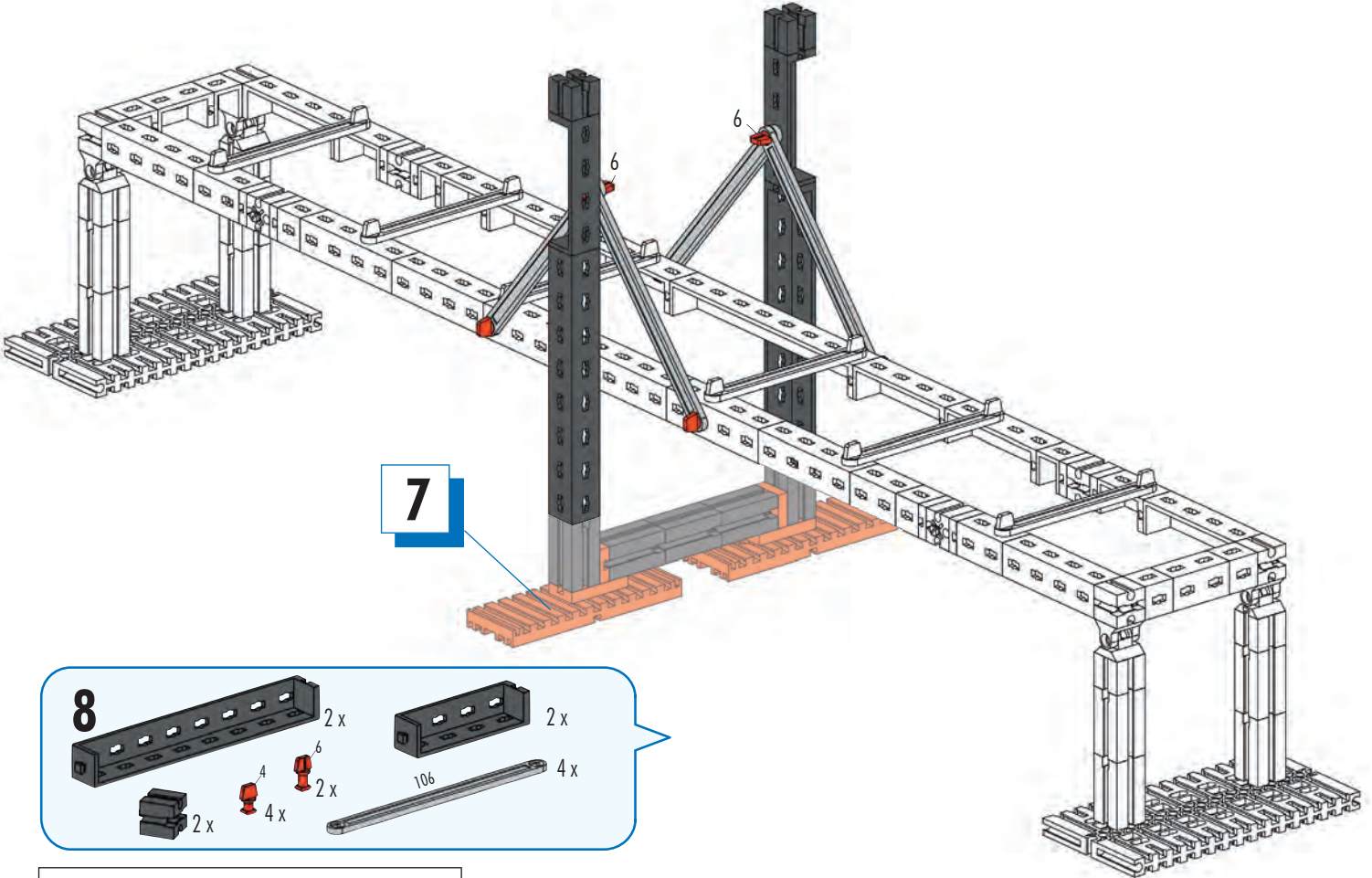
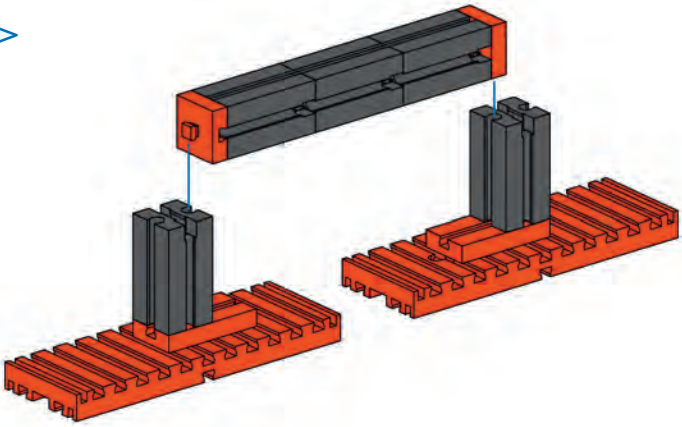

8

- 2 x (black Technic axle)
- 2 x (black Technic axle)
- 2 x (red Technic bush)
- 4 x (red Technic bush)
- 2 x (red Technic bush)
- 4 x (grey Technic axle, length 106)

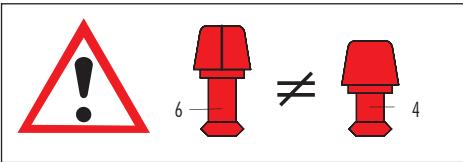

9

- 4 x (grey Technic axle, length 106)
- 4 x (grey Technic axle, length 63.6)
- 4 x (red Technic bush)
- 8 x (red Technic bush)

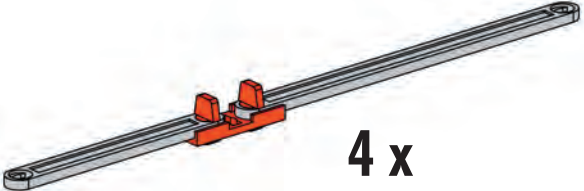

10

- 106 4 x
- 63,6 8 x
- 30 4 x
- 15 4 x
- 4 16 x

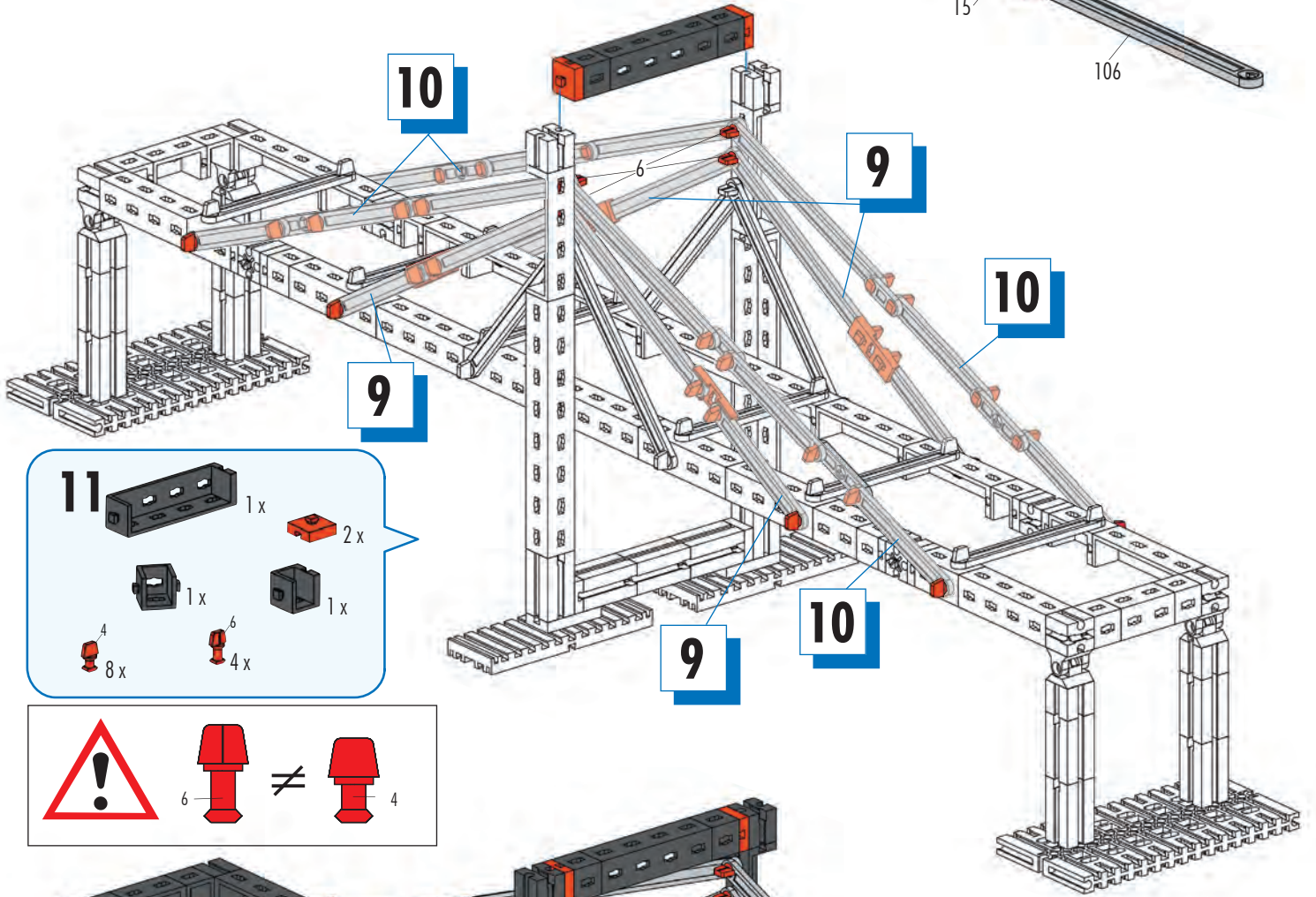
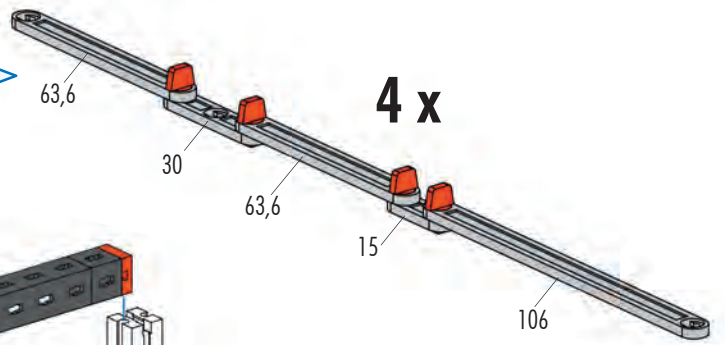

11

- 1 x
- 2 x
- 1 x
- 1 x
- 4 8 x
- 6 4 x

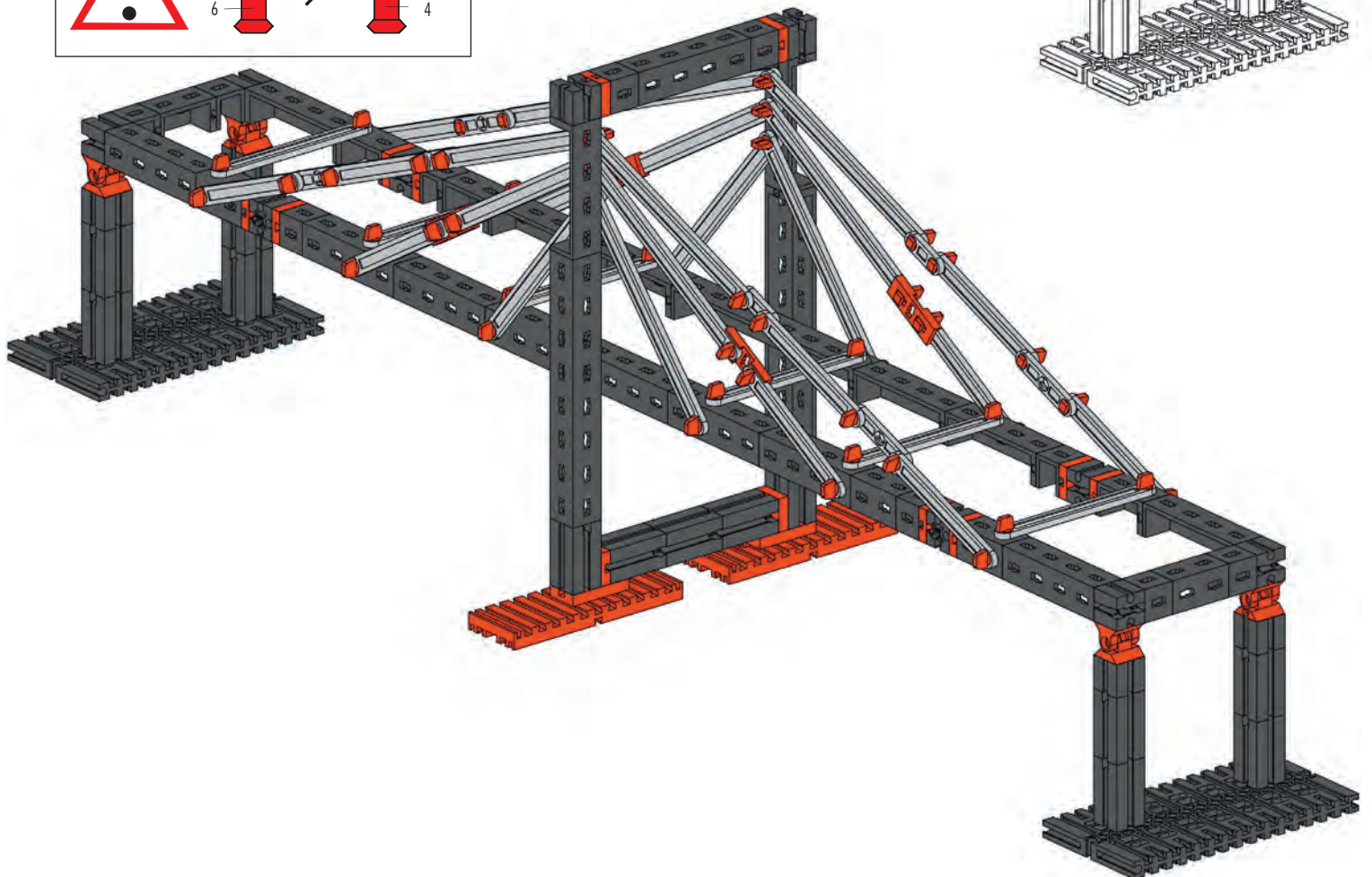
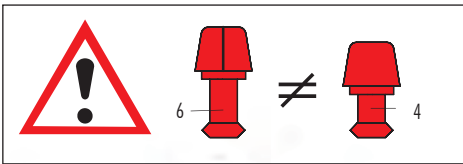





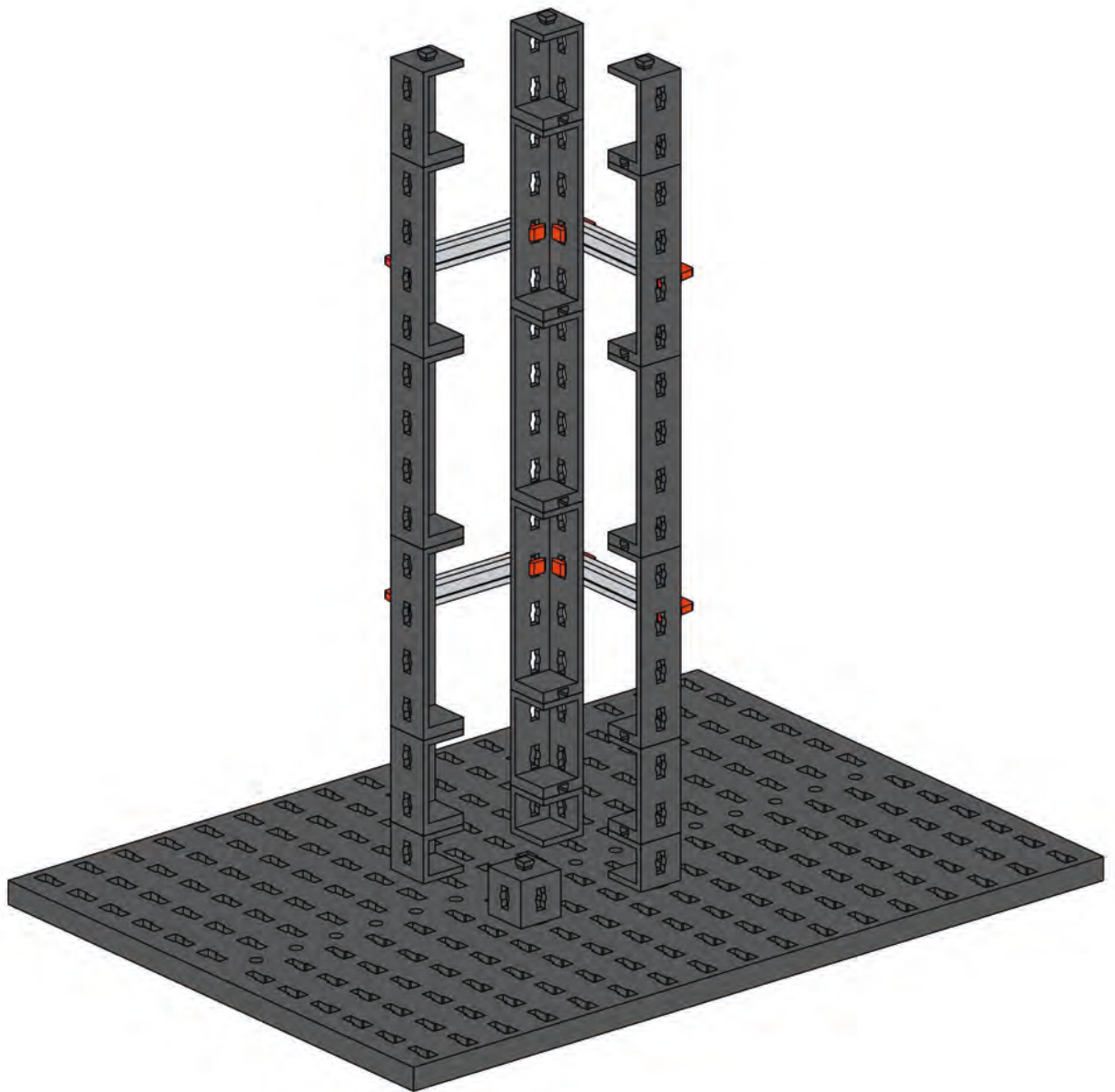
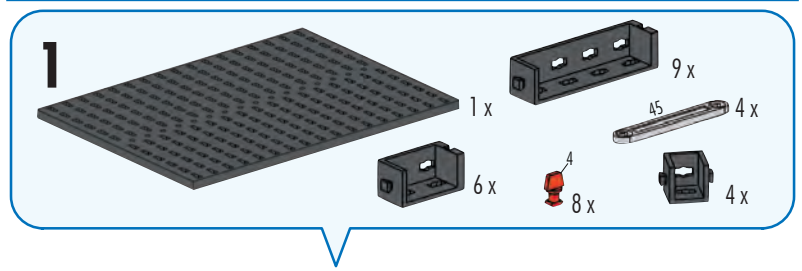

Kran
Crane
Grue

Kraan
Grúa
Guindaste

Gru
Кран
起重机



2  3 x  12 x  6 x

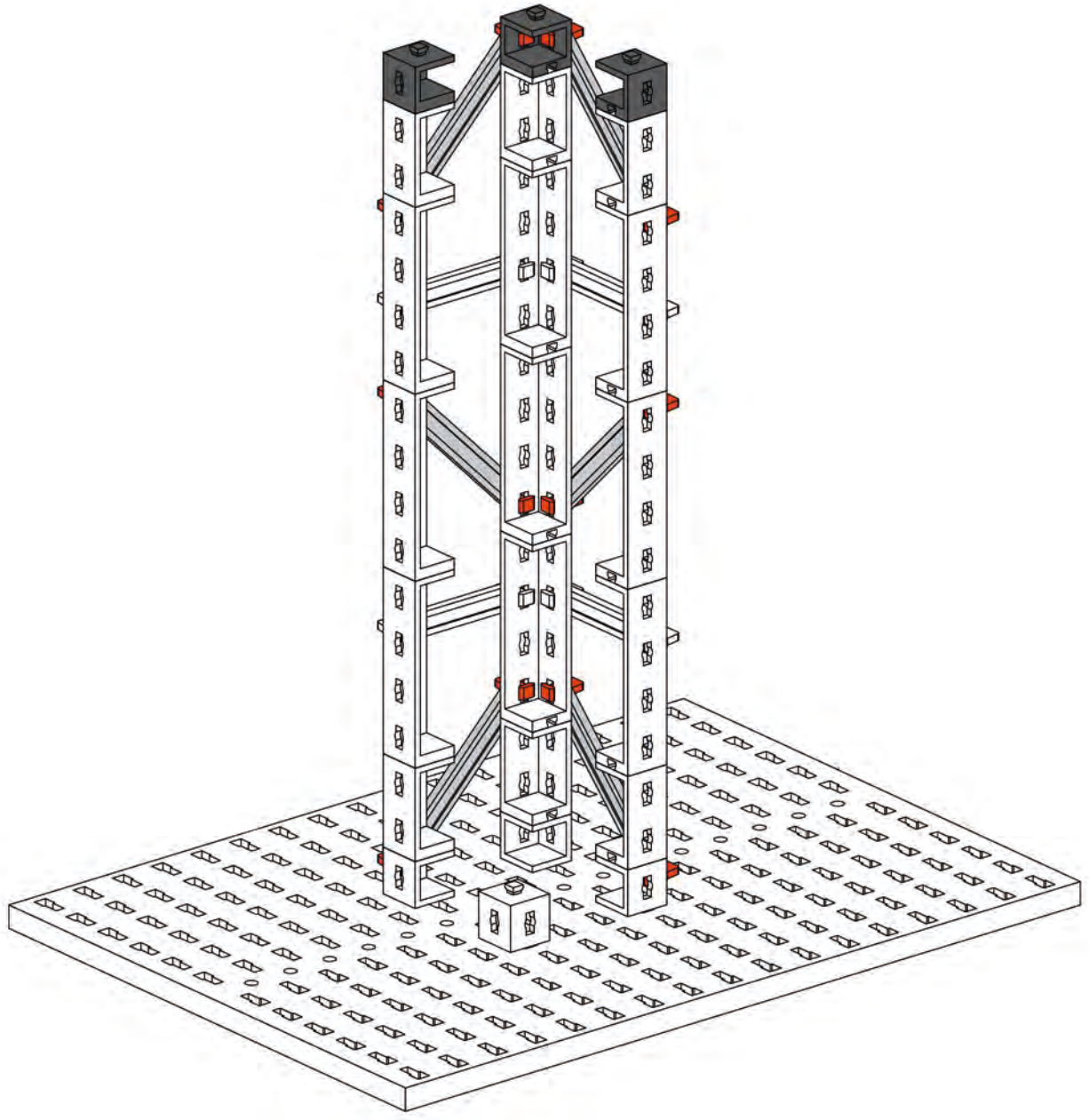

3

- 3 x [Black 1x3 Technic Beam]
- 2 x [Black 1x2 Technic Beam]
- 1 x [Black 1x1 Technic Beam]
- 45 [Grey Technic Pin]
- 4 x [Grey Technic Pin]
- A [Red Technic Pin]
- 8 x [Red Technic Pin]

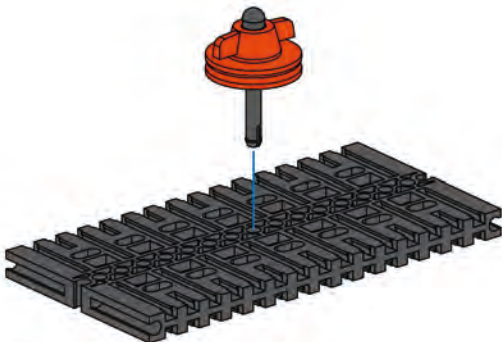
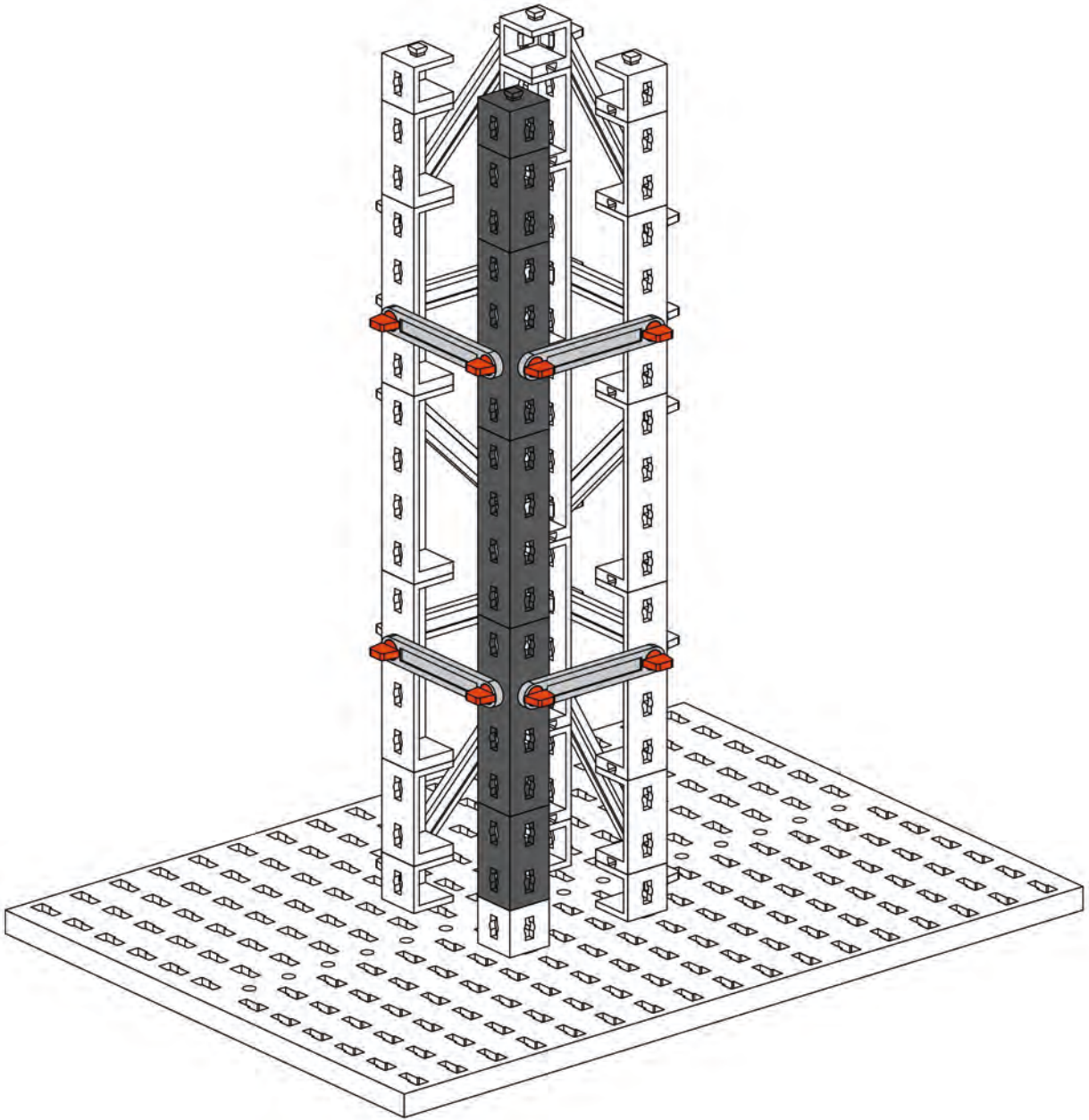

4

- 1 x [Black 1x10 Technic Beam]
- 1 x [Red Technic Pin]
- 1 x [Red Technic Pin]
- 1 x [Grey Technic Pin]

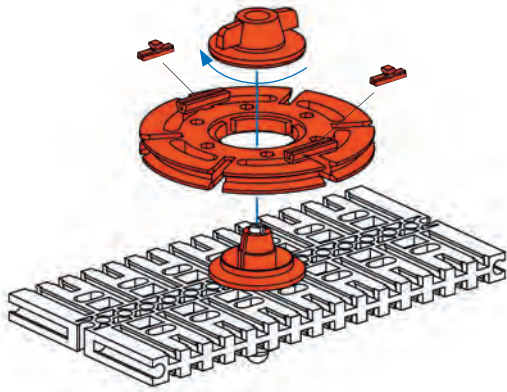

5

- 1 x
- 1 x
- 1 x
- 2 x

6

- 4 x

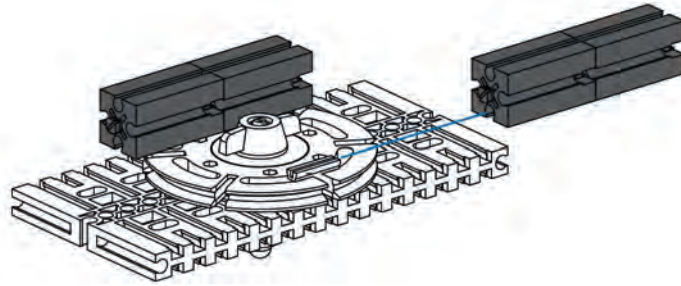

6

7

- 12 x
- 6 x

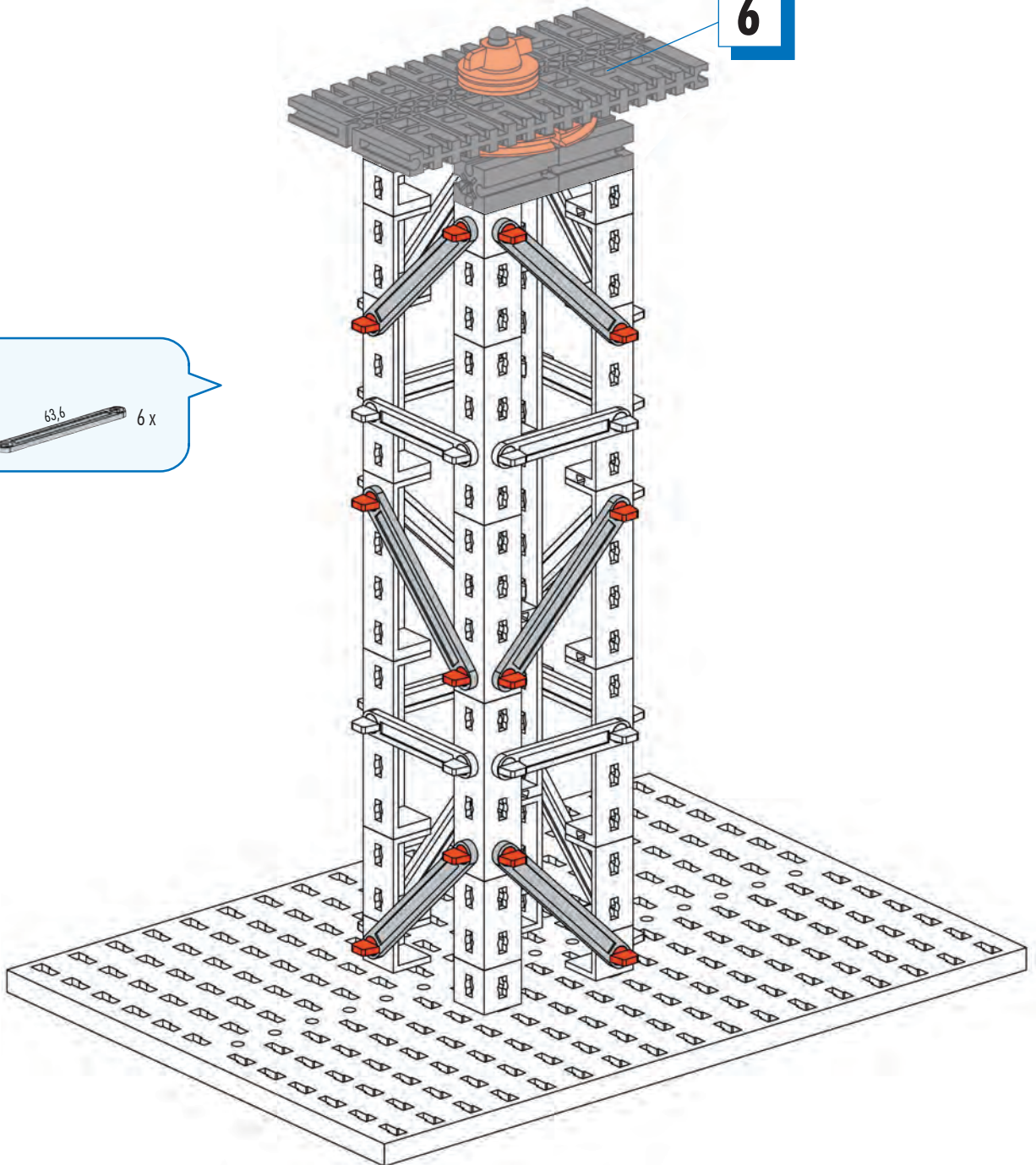

- 8**
- 4 x [Red 1x2 Technic Brick]
 - 1 x [Red L-shaped Technic Connector]
 - 1 x [Grey Technic Pin]
 - 3 x [Red 1x2 Technic Brick with Hole]
 - 1 x [Red 60° Technic Wedge]
 - 1 x [Red Technic Connector]
 - 1 x [Red 30mm Technic Beam]
 - 1 x [Grey 30mm Technic Pin]
 - 1 x [Grey Technic Pin]

30 mm

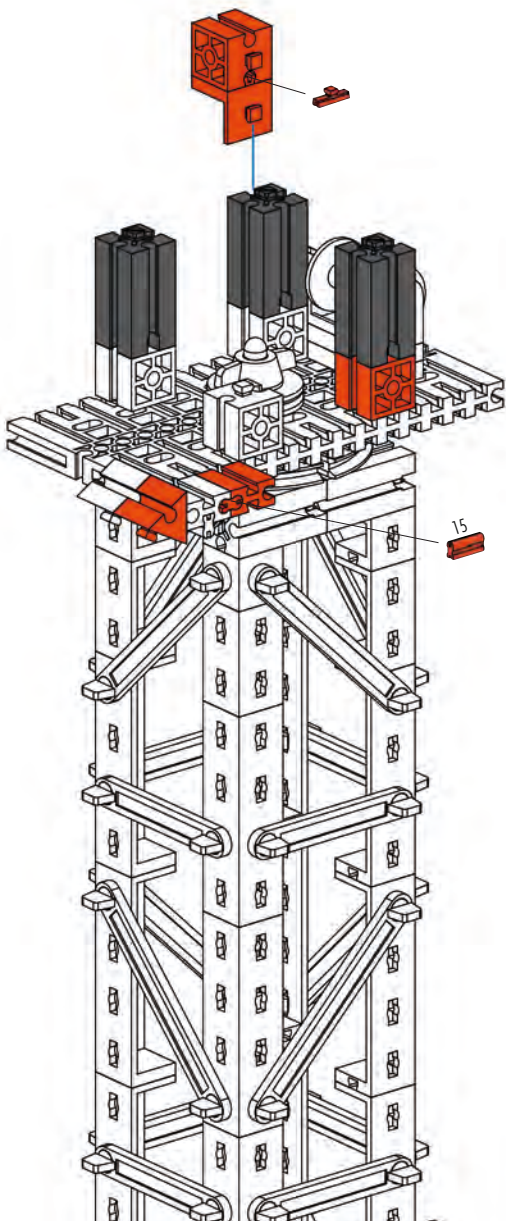
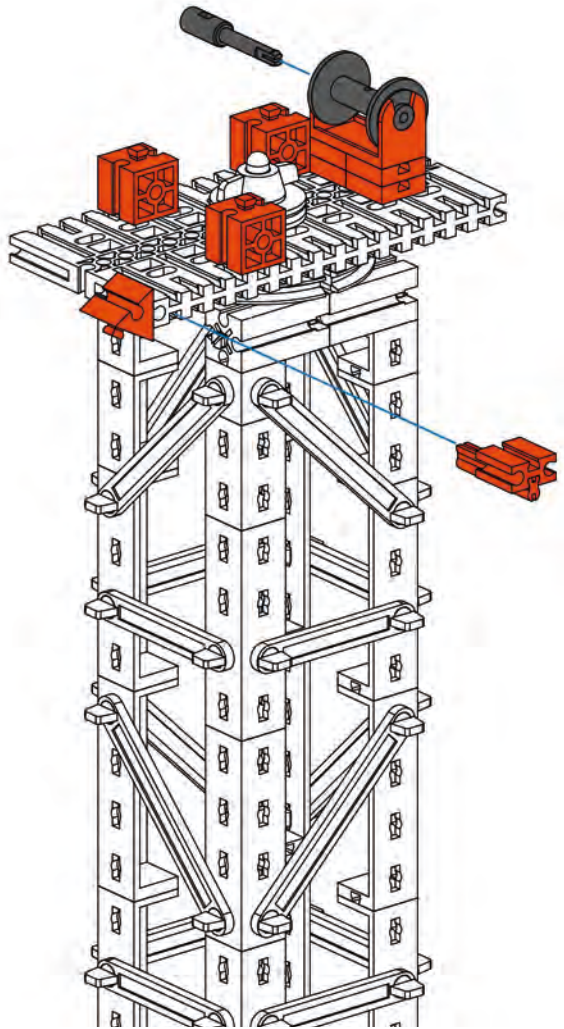

- 9**
- 3 x [Grey Technic Beam]
 - 2 x [Red 1x2 Technic Brick with Hole]
 - 1 x [Red 60° Technic Wedge]
 - 1 x [Red L-shaped Technic Connector]
 - 1 x [Red Technic Connector]
 - 1 x [Red 15mm Technic Beam]
 - 1 x [Red Technic Connector]

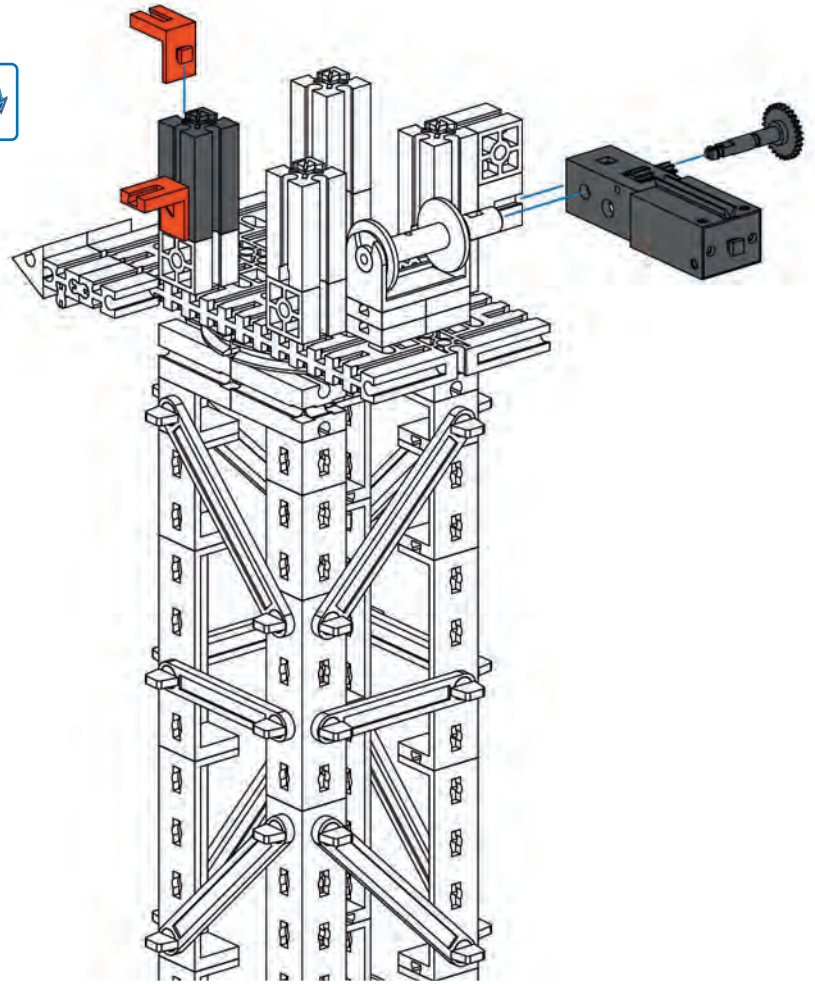

10

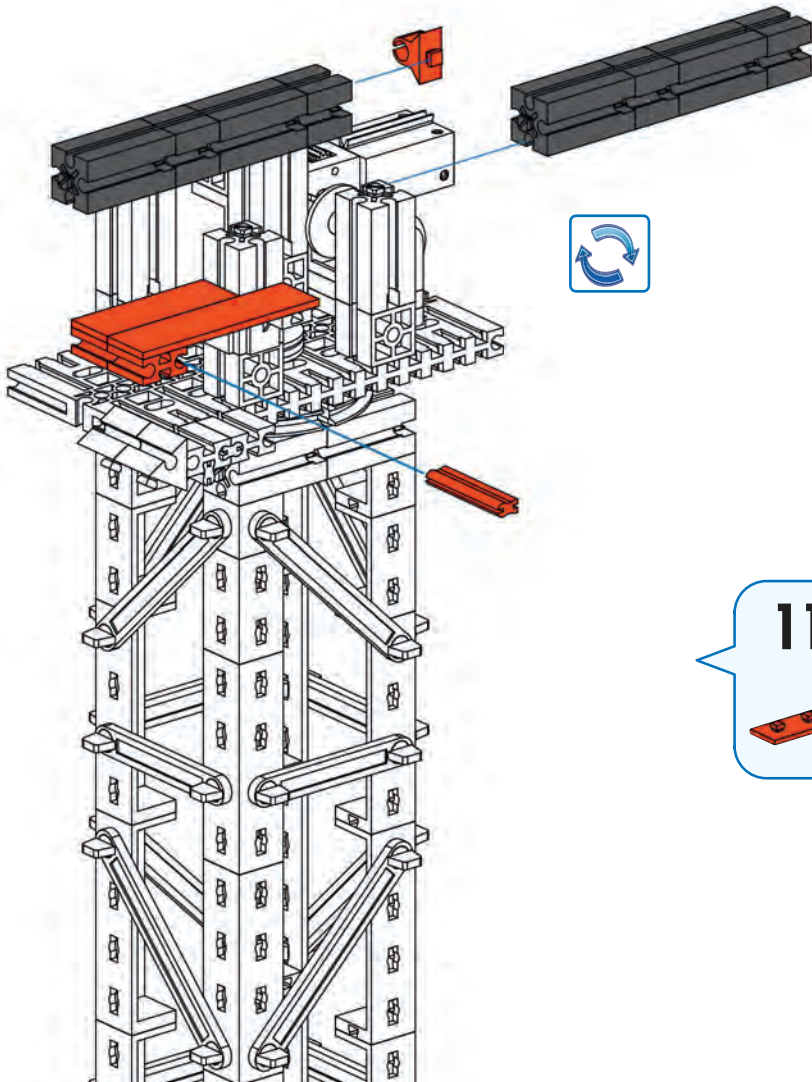

11



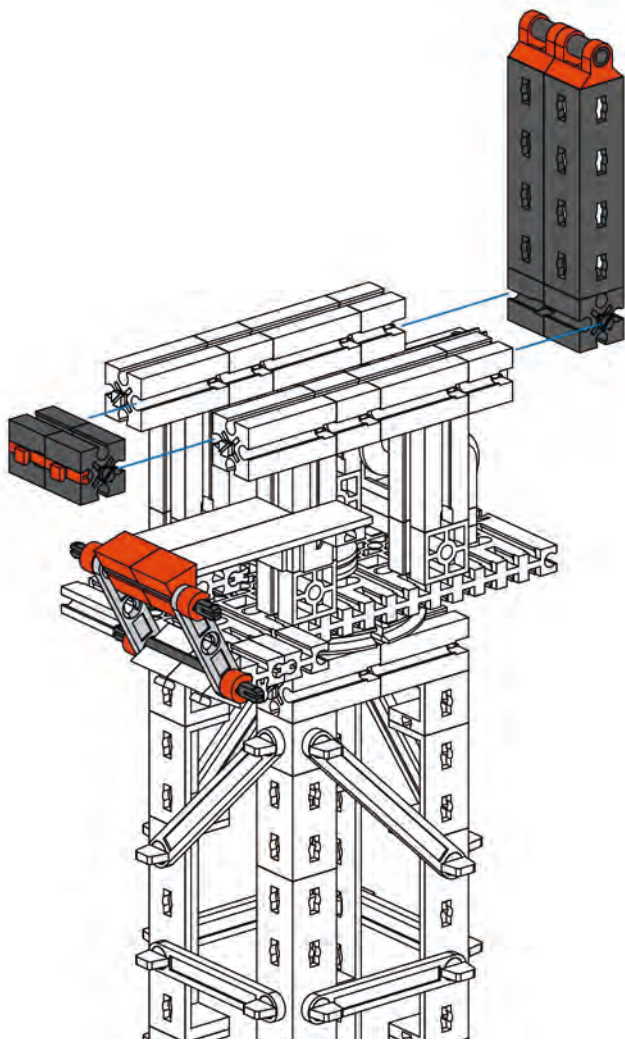

- 12**
- 2 x [Grey 2-hole Technic Pin]
 - 2 x [Grey 2-hole Technic Pin]
 - 2 x [Grey 1-hole Technic Beam]
 - 2 x [Grey 60mm Technic Pin]
 - 2 x [Red 30° Technic Pin]
 - 2 x [Red 30° Technic Pin]
 - 2 x [Red 30° Technic Pin]
 - 2 x [Grey 30mm Technic Pin]
 - 4 x [Red 1-hole Technic Pin]

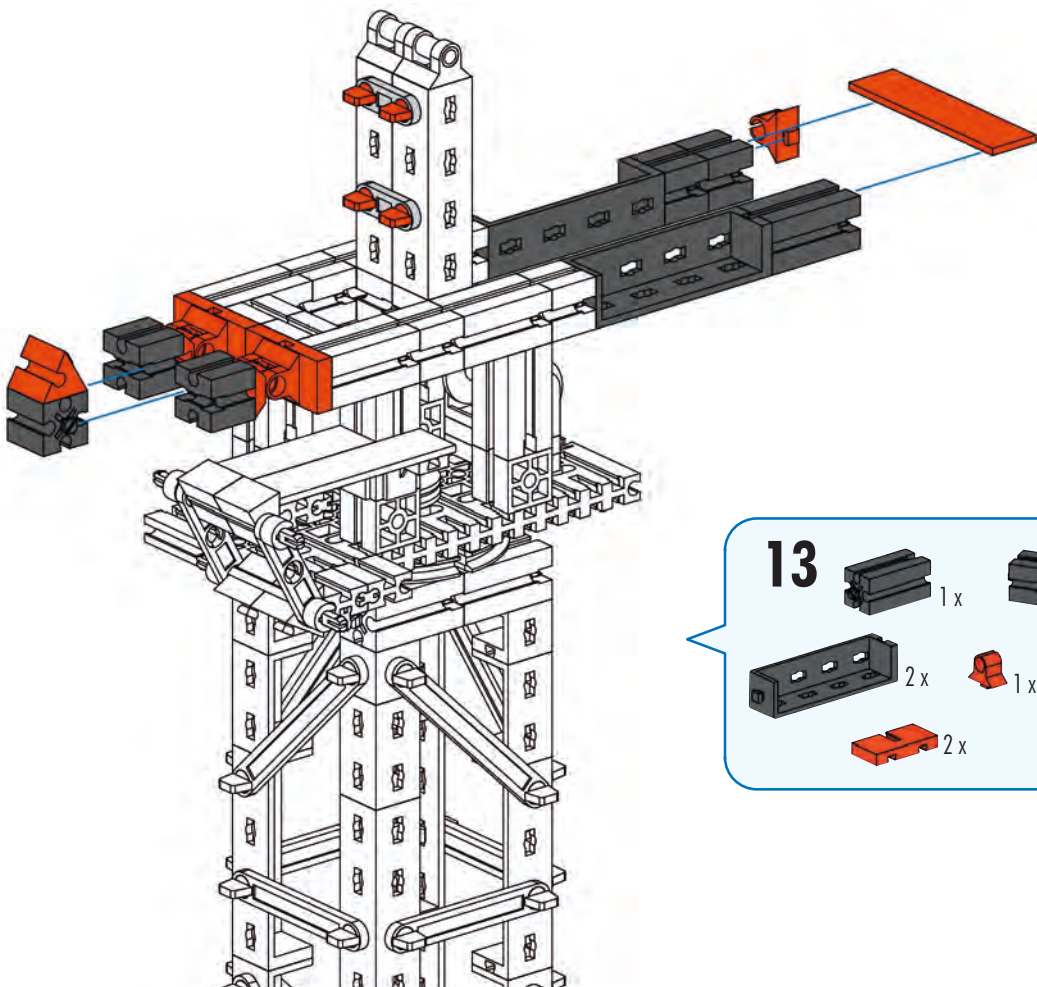
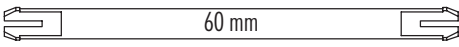

- 13**
- 1 x [Grey 2-hole Technic Pin]
 - 4 x [Grey 2-hole Technic Pin]
 - 1 x [Grey 2-hole Technic Pin]
 - 1 x [Red 60° Technic Pin]
 - 2 x [Grey 1-hole Technic Beam]
 - 1 x [Red 1-hole Technic Pin]
 - 2 x [Grey 15mm Technic Pin]
 - 4 x [Red 4-hole Technic Pin]
 - 2 x [Red 2-hole Technic Pin]
 - 2 x [Red 2-hole Technic Pin]
 - 1 x [Red 1-hole Technic Beam]

14

- 120 2 x
- 90 2 x
- 4 4 x
- 2 x

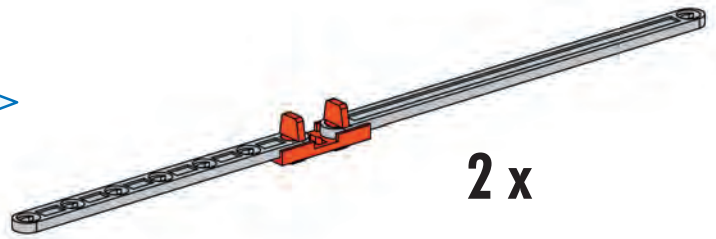



15

- 2 x
- 2 x
- 2 x
- 4 4 x
- 60 1 x
- 106 2 x
- 2 x

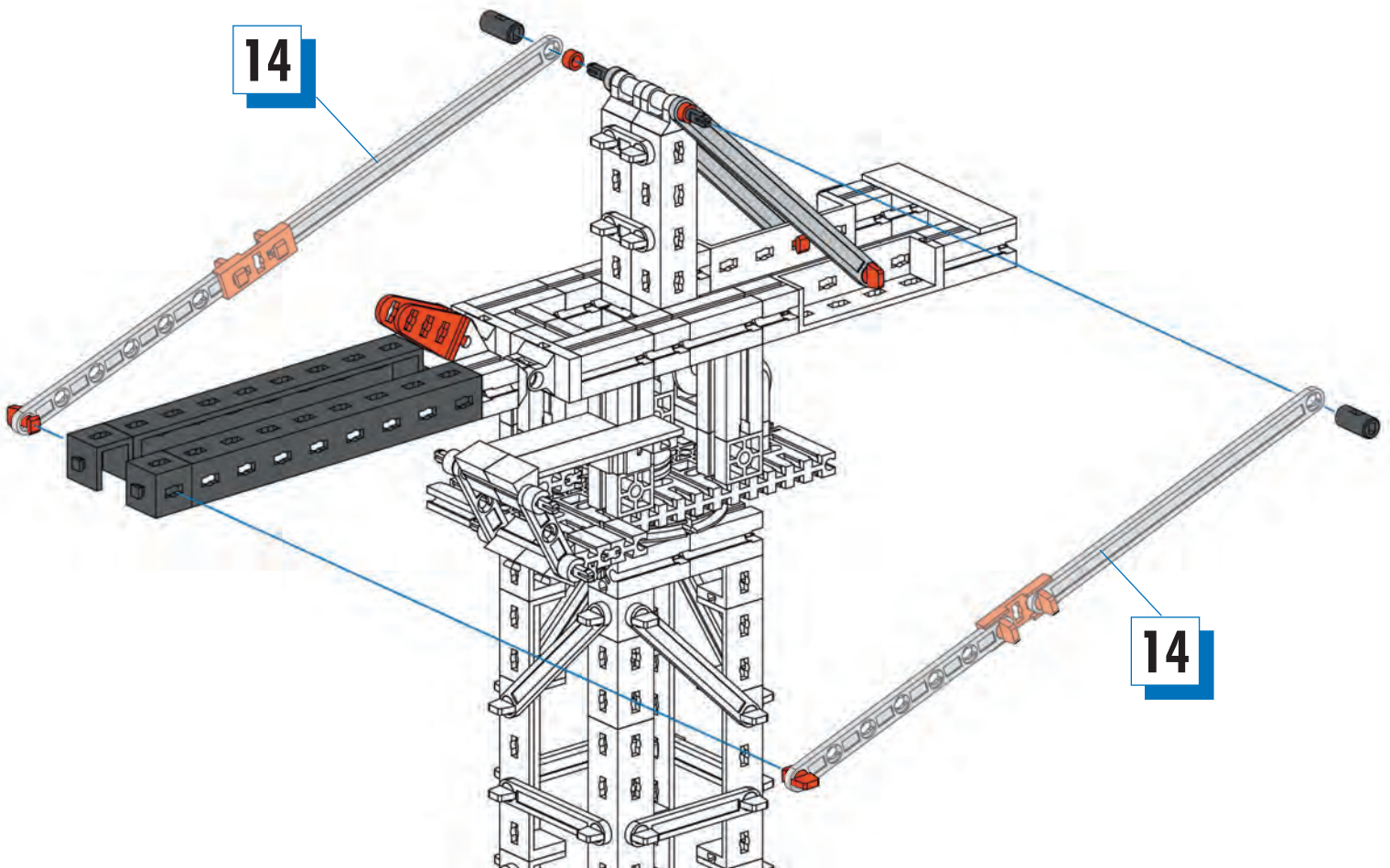

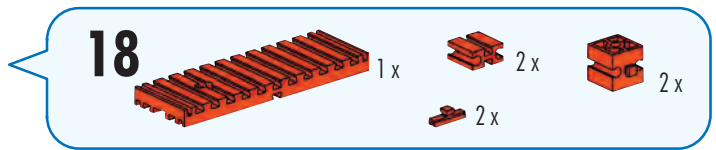
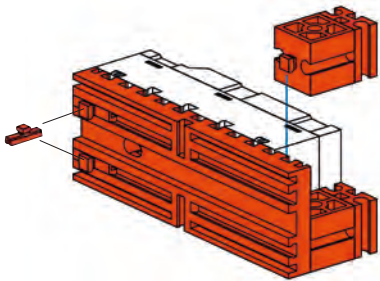
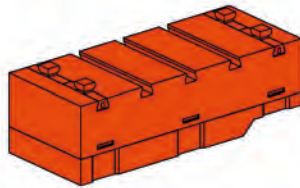
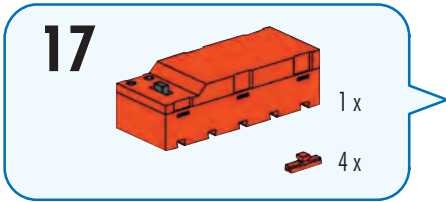
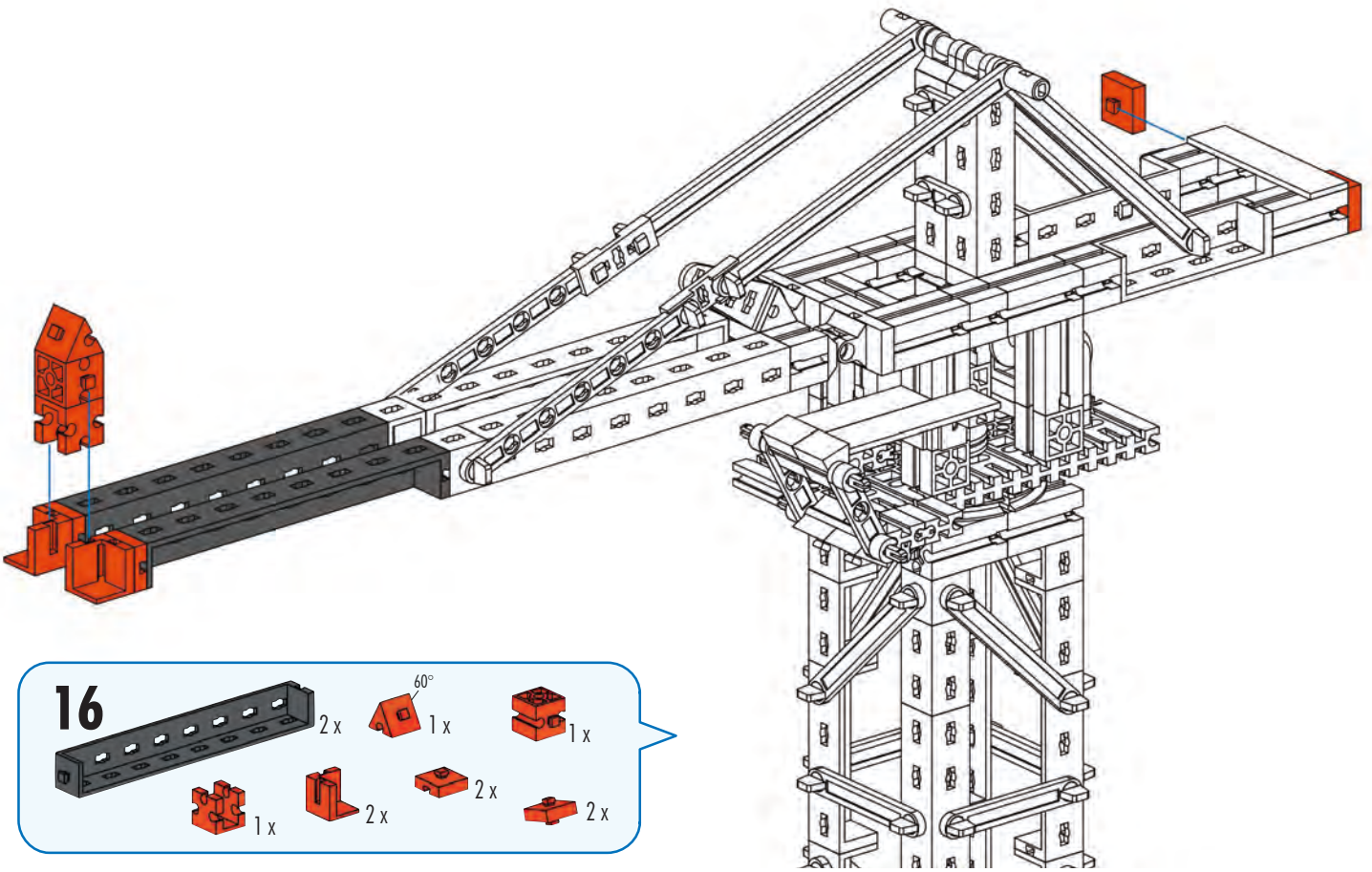

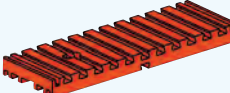
60 mm



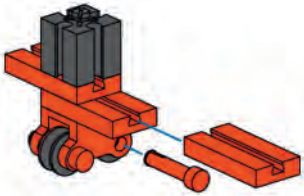
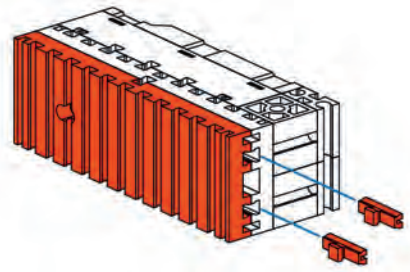

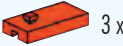



19  1x  2x

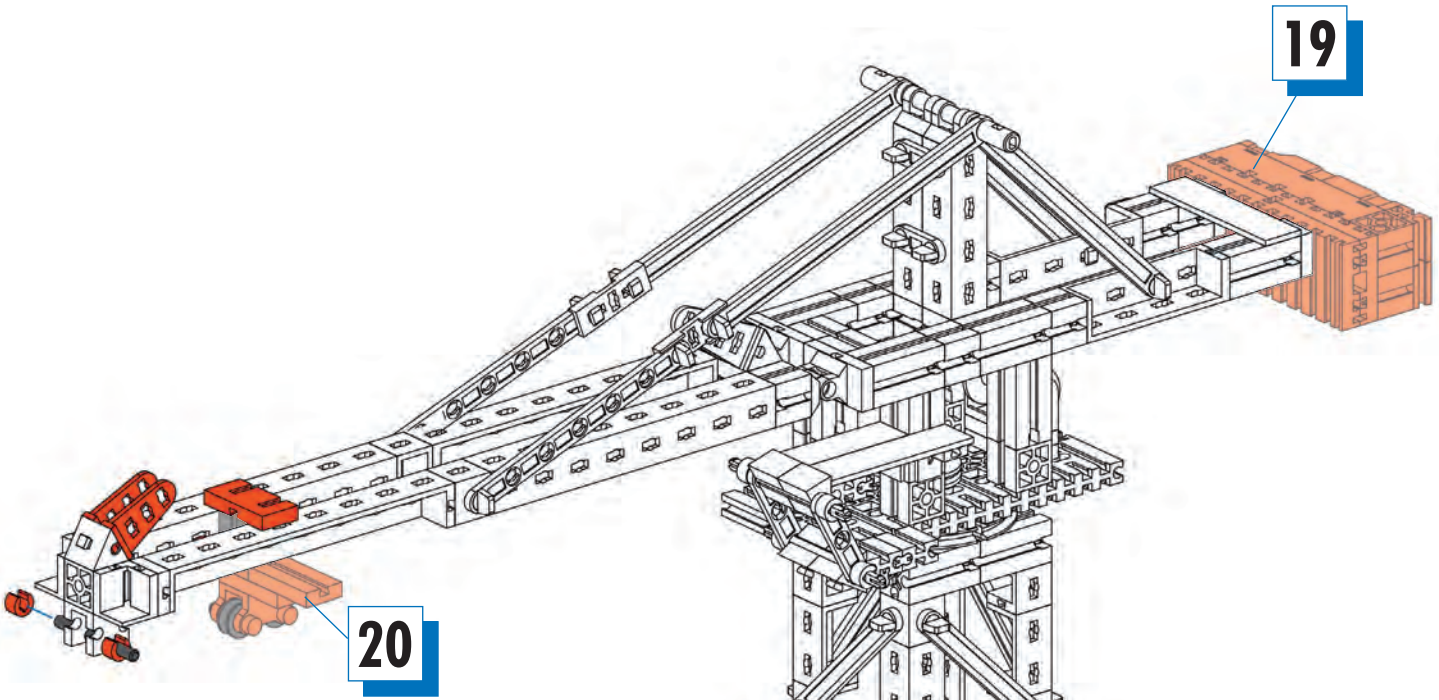

20  1x  3x  1x  2x  2x



21  2x  1x  1x  2x

40 mm



2 x

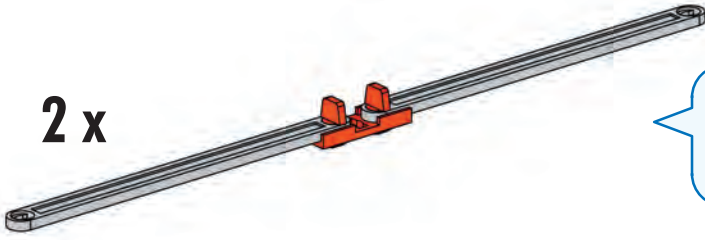

22



23



22

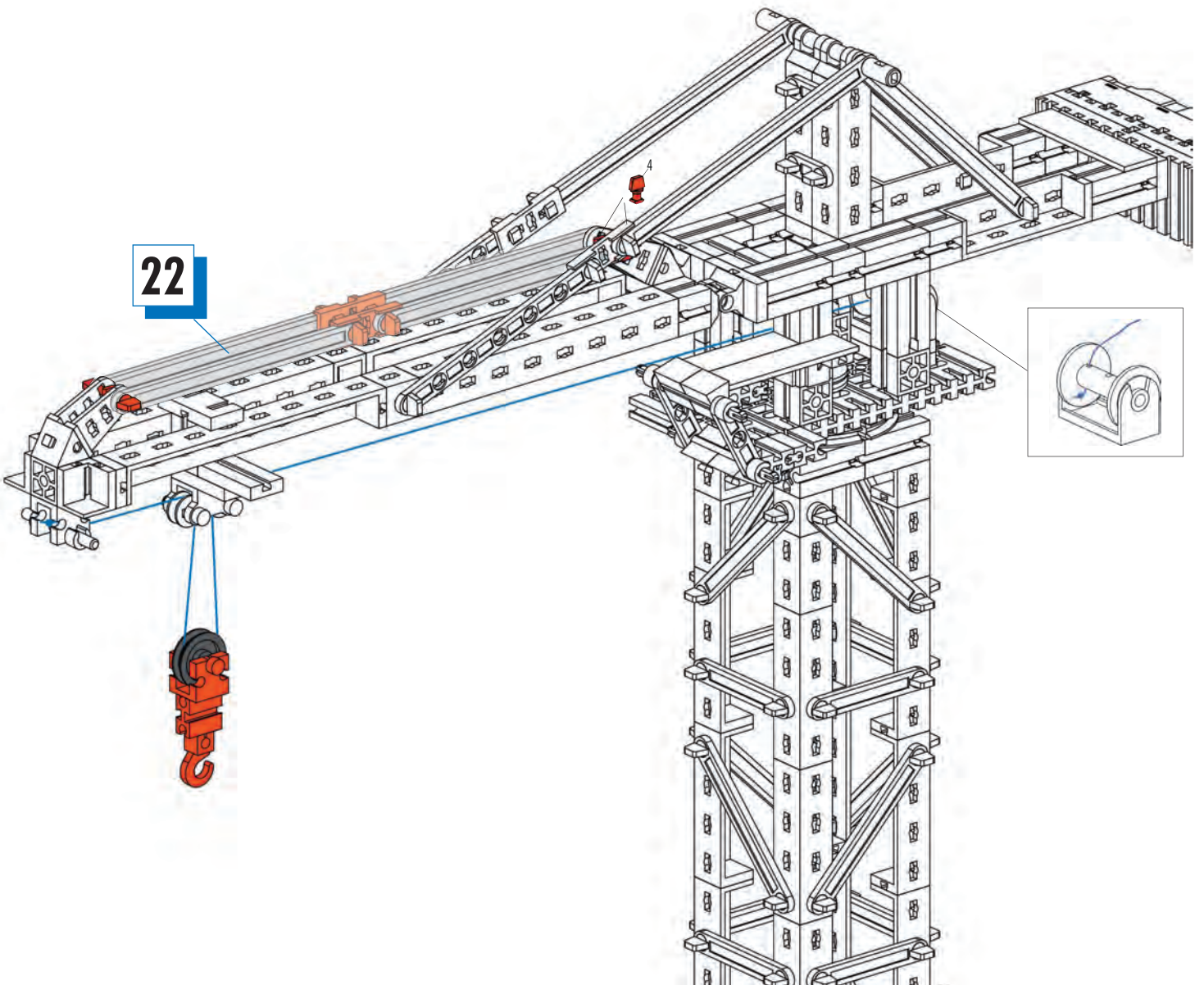

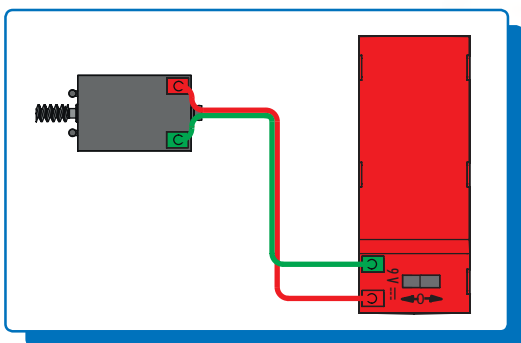
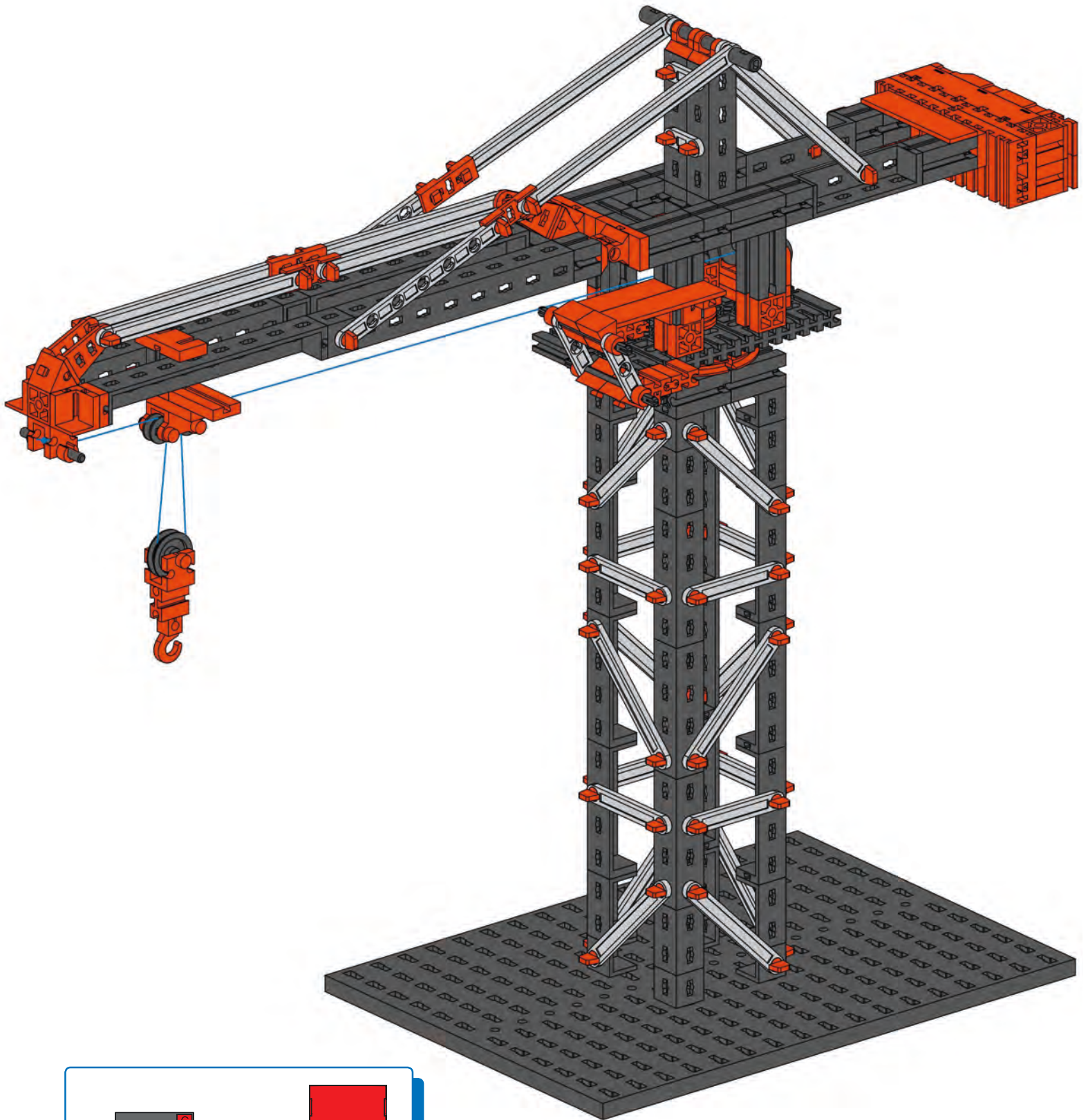

Empfohlene Aufbewahrung:	4 x Aufbewahrungssystem Art.-Nr. 94828
Recommended storage:	4 x storage system Art No. 94828
Stockage conseillé :	4 x système de stockage Art n° 94828
Bewaaradvies:	4 x bewaarsysteem art.-nr. 94828
Consejos para guardar el producto:	4 x almacenamiento Art. N° 94828
Conservação recomendada:	4 x sistema de conservação n.º de art. 94828
Conservazione consigliata:	4 sistemi di conservazione, cod. prod. 94828
Рекомендуемое хранение:	4 x бокса для хранения. Арт.№ 94 828
推荐的保存方式 :	4个产品号为 94 828 的保存系统

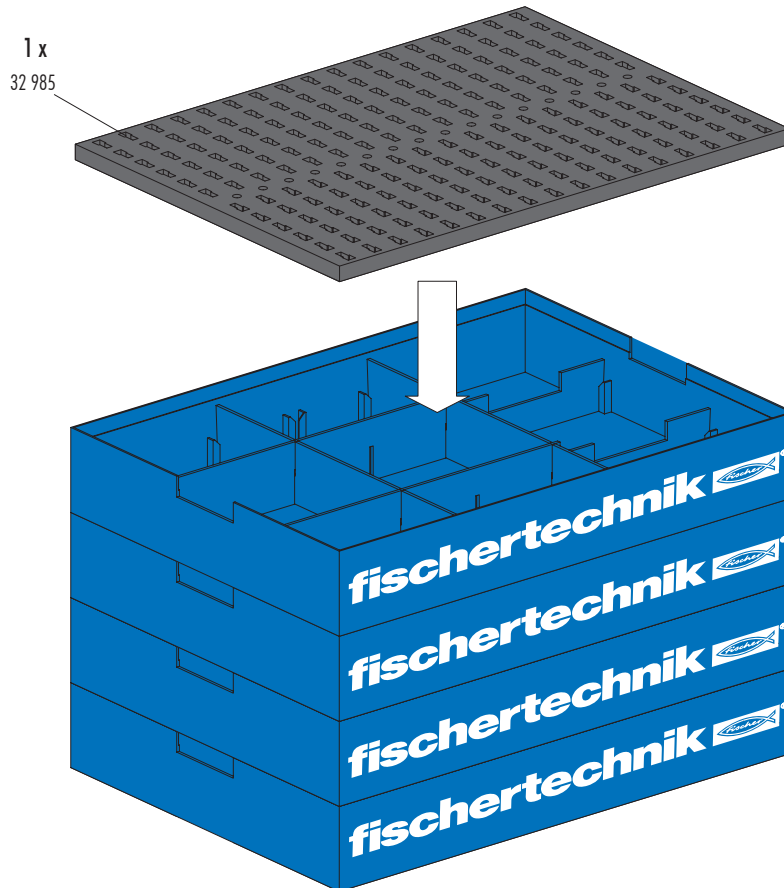

Sortiervorschlag / Storage suggestion / Suggestion de classement / Sorteervoorstel / Propuesta de clasificación / Proposta de divisão / Proposta di sistemazione / Рекомендации по сортировке / 保存系统的分类建议:

www.fischertechnik.de/Sortiervorschläge



Hinweise zum Umweltschutz / Instructions for Environmental Protection / Remarques de protection de l'environnement / Bescherming van het milieu / Notas con respecto a la protección del medio ambiente / Instruções para a proteção do meio ambiente / Indicazioni sulla tutela ambientale / Указания по охране окружающей среды / 有关环保的提示 :

www.fischertechnik.de/environment



fischertechnik 

PROFI

fischertechnik GmbH
Klaus-Fischer-Str. 1
72178 Waldachtal
Germany
Phone: +49 74 43/12-43 69
Fax: +49 74 43/12-45 91
info@fischertechnik.de
www.fischertechnik.de

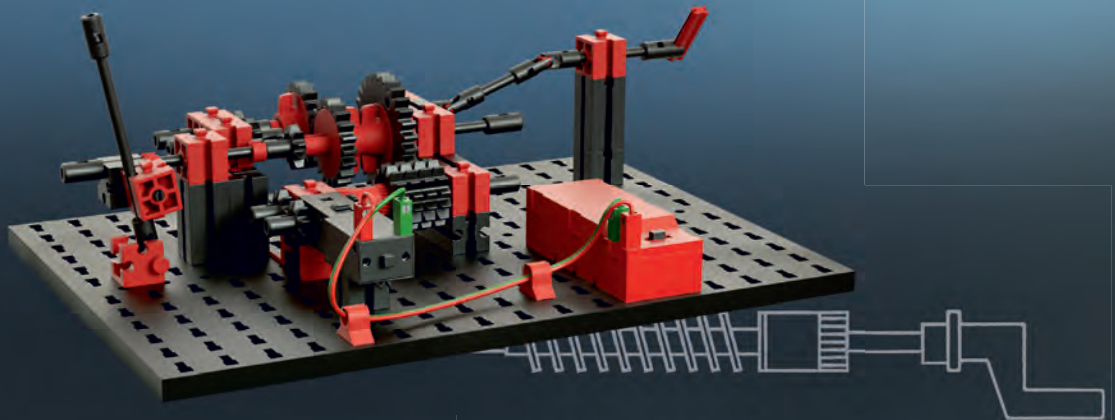
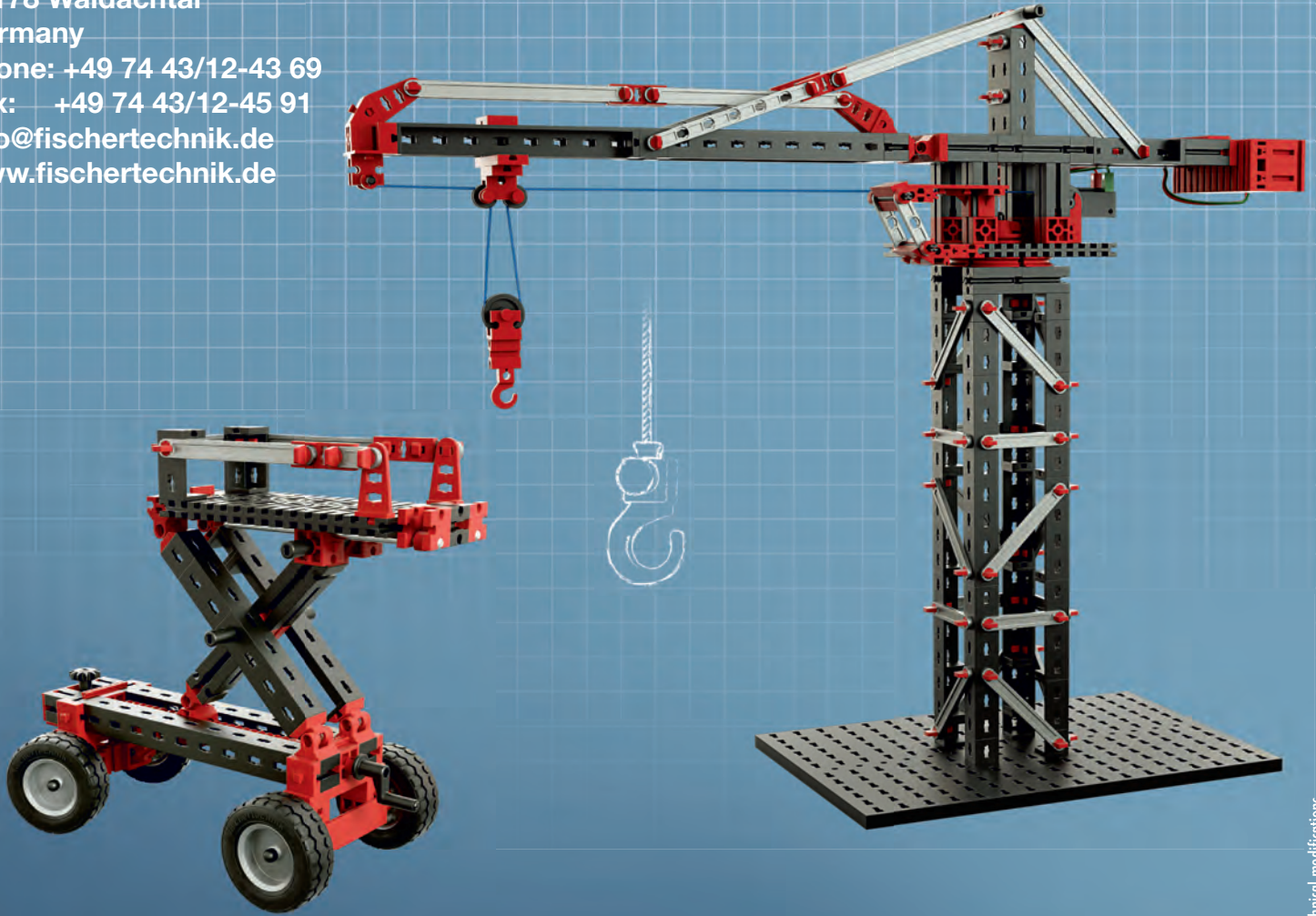

Mechanics & Static 2

30 MODELS